

Simple Stresses

Simple stresses are expressed as the ratio of the applied force divided by the resisting area or

$$\sigma = \text{Force} / \text{Area}.$$

It is the expression of force per unit area to structural members that are subjected to external forces and/or induced forces. Stress is the lead to accurately describe and predict the elastic deformation of a body.

Simple stress can be classified as normal stress, shear stress, and bearing stress.

Normal stress develops when a force is applied perpendicular to the cross-sectional area of the material. If the force is going to pull the material, the stress is said to be **tensile stress** and **compressive stress** develops when the material is being compressed by two opposing forces. **Shear stress** is developed if the applied force is parallel to the resisting area. Example is the bolt that holds the tension rod in its anchor. Another condition of shearing is when we twist a bar along its longitudinal axis. This type of shearing is called torsion and covered in Chapter 3. Another type of simple stress is the **bearing stress**, it is the contact pressure between two bodies.

Suspension bridges are good example of structures that carry these stresses. The weight of the vehicle is carried by the bridge deck and passes the force to the stringers (vertical cables), which in turn, supported by the main suspension cables. The suspension cables then transferred the force into bridge towers.



Normal Stress

Stress

Stress is the expression of force applied to a unit area of surface. It is measured in psi (English unit) or in MPa (SI unit). Another unit of stress which is not commonly used is the dynes (cgs unit). Stress is the ratio of force over area.

$$\text{stress} = \text{force} / \text{area}$$

Simple Stresses

There are three types of simple stress namely; normal stress, shearing stress, and bearing stress.

Normal Stress

The resisting area is perpendicular to the applied force, thus normal. There are two types of normal stresses; tensile stress and compressive stress. Tensile stress applied to bar tends the bar to elongate while compressive stress tend to shorten the bar.

$$\sigma = \frac{P}{A}$$

where P is the applied normal load in Newton and A is the area in mm². The maximum stress in tension or compression occurs over a section normal to the load.

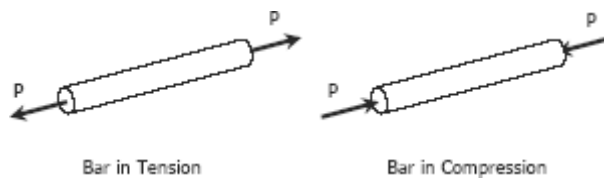

SOLVED PROBLEMS IN NORMAL STRESS

Problem 104

A hollow steel tube with an inside diameter of 100 mm must carry a tensile load of 400 kN. Determine the outside diameter of the tube if the stress is limited to 120 MN/m².

Solution 104

$$P = \sigma A$$

where:

$$P = 400 \text{ kN} = 400\,000 \text{ N}$$

$$\sigma = 120 \text{ MPa}$$

$$A = \frac{1}{4}\pi D^2 - \frac{1}{4}\pi(100)^2$$

$$= \frac{1}{4}\pi(D^2 - 10\,000)$$

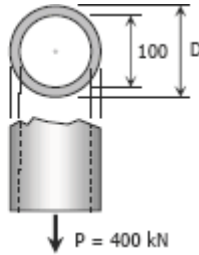

thus,

$$400\,000 = 120\left[\frac{1}{4}\pi(D^2 - 10\,000)\right]$$

$$400\,000 = 30\pi D^2 - 300\,000\pi$$

$$D^2 = \frac{400\,000 + 300\,000\pi}{30\pi}$$

$$D = 119.35 \text{ mm}$$

Problem 105

A homogeneous 800 kg bar AB is supported at either end by a cable as shown in Fig. P-105. Calculate the smallest area of each cable if the stress is not to exceed 90 MPa in bronze and 120 MPa in steel.

Figure P-105

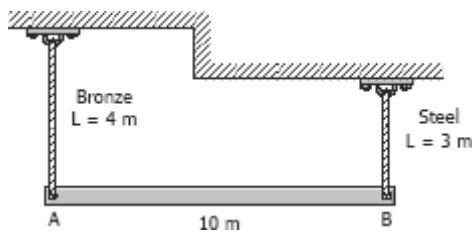

Solution 105

By symmetry:

$$P_{br} = P_{st} = \frac{1}{2}(7848)$$

$$= 3924 \text{ N}$$

For bronze cable:

$$P_{br} = \sigma_{br} A_{br}$$

$$3924 = 90 A_{br}$$

$$A_{br} = 43.6 \text{ mm}^2$$

For steel cable:

$$P_{st} = \sigma_{st} A_{st}$$

$$3924 = 120 A_{st}$$

$$A_{st} = 32.7 \text{ mm}^2$$

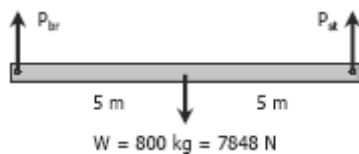

Problem 106

The homogeneous bar shown in Fig. P-106 is supported by a smooth pin at C and a cable that runs from A to B around the smooth peg at D. Find the stress in the cable if its diameter is 0.6 inch and the bar weighs 6000 lb.

Figure P-106

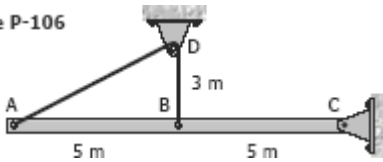

Solution 106

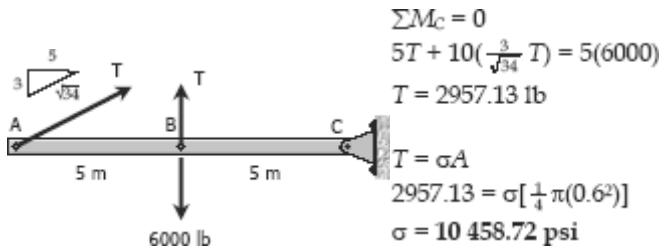

Problem 107

A rod is composed of an aluminum section rigidly attached between steel and bronze sections, as shown in Fig. P-107. Axial loads are applied at the positions indicated. If $P = 3000 \text{ lb}$ and the cross sectional area of the rod is 0.5 in^2 , determine the stress in each section.

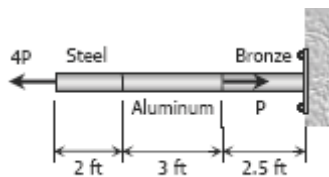
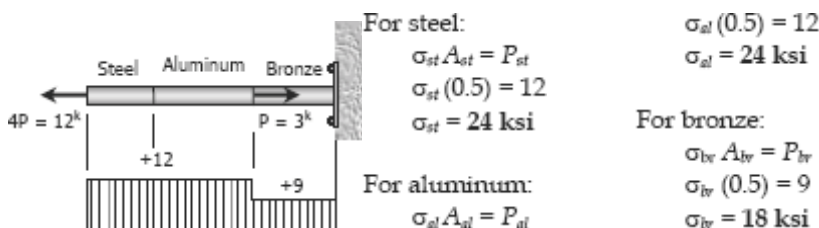

Figure P-107

Solution 107



Problem 108

An aluminum rod is rigidly attached between a steel rod and a bronze rod as shown in Fig. P-108. Axial loads are applied at the positions indicated. Find the maximum value of P that will not exceed a stress in steel of 140 MPa, in aluminum of 90 MPa, or in bronze of 100 MPa.

Figure P-108

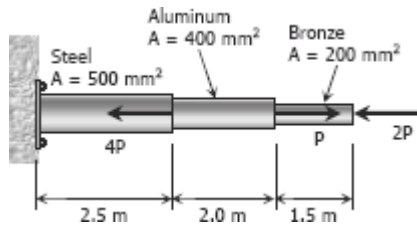

Solution 108

For bronze:

$$\sigma_{br} A_{br} = 2P$$

$$100(200) = 2P$$

$$P = 10\,000 \text{ N}$$

For aluminum:

$$\sigma_{al} A_{al} = P$$

$$90(400) = P$$

$$P = 36\,000 \text{ N}$$

For Steel:

$$\sigma_{st} A_{st} = 5P$$

$$P = 14\,000 \text{ N}$$

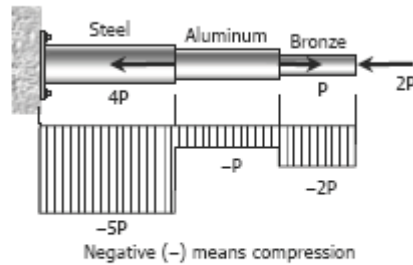

For safe P , use $P = 10\,000 \text{ N} = 10 \text{ kN}$

Problem 109

Determine the largest weight W that can be supported by two wires shown in Fig. P-109. The stress in either wire is not to exceed 30 ksi. The cross-sectional areas of wires AB and AC are 0.4 in^2 and 0.5 in^2 , respectively.

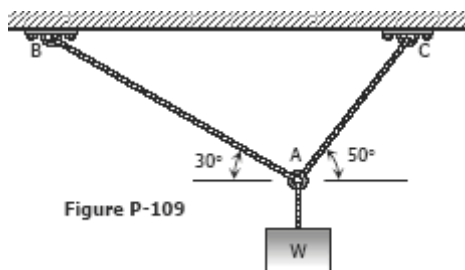

Solution 109

For wire AB:

By sine law (from the force polygon):

$$\frac{T_{AB}}{\sin 40^\circ} = \frac{W}{\sin 80^\circ}$$

$$T_{AB} = 0.6527W$$

$$\sigma_{AB}A_{AB} = 0.6527W$$

$$30(0.4) = 0.6527W$$

$$W = 18.4 \text{ kips}$$

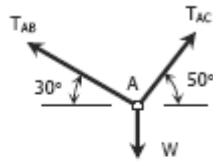

FBD of knot A

For wire AC:

$$\frac{T_{AC}}{\sin 60^\circ} = \frac{W}{\sin 80^\circ}$$

$$T_{AC} = 0.8794W$$

$$T_{AC} = \sigma_{AC}A_{AC}$$

$$0.8794W = 30(0.5)$$

$$W = 17.1 \text{ kips}$$

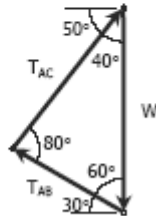

Force polygon of forces on knot A

Safe load $W = 17.1$ kips

Problem 110

A 12-inches square steel bearing plate lies between an 8-inches diameter wooden post and a concrete footing as shown in Fig. P-110. Determine the maximum value of the load P if the stress in wood is limited to 1800 psi and that in concrete to 650 psi.

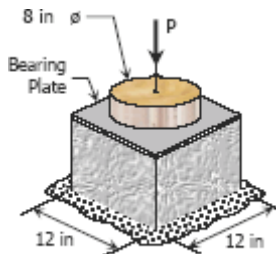

Figure P-110

Solution 110

For wood:

$$\begin{aligned} P_w &= \sigma_w A_w \\ &= 1800 \left[\frac{1}{4} \pi (8^2) \right] \\ &= 90\,477.9 \text{ lb} \end{aligned}$$

From FBD of Wood:

$$P = P_w = 90\,477.9 \text{ lb}$$

For concrete:

$$\begin{aligned} P_c &= \sigma_c A_c \\ &= 650(12^2) \\ &= 93\,600 \text{ lb} \end{aligned}$$

From FBD of Concrete:

$$P = P_c = 93\,600 \text{ lb}$$

Safe load $P = 90\,478 \text{ lb}$

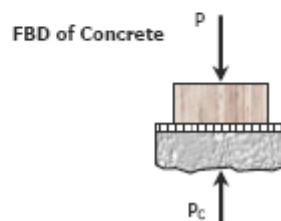
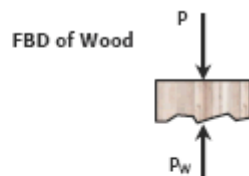

Problem 111

For the truss shown in Fig. P-111, calculate the stresses in members CE, DE, and DF. The cross-sectional area of each member is 1.8 in^2 . Indicate tension (T) or compression (C).

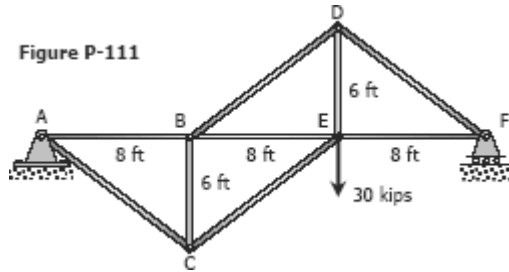

Solution 111

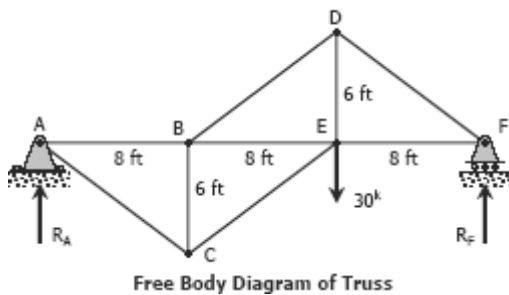

From the FBD of the truss:

$$\begin{aligned}\sum M_A &= 0 \\ 24R_B &= 16(30) \\ R_F &= 20^k\end{aligned}$$

At joint F:

$$\begin{aligned}\sum F_V &= 0 \\ \frac{3}{5}DF &= 20 \\ DF &= 33\frac{1}{3}^k (C)\end{aligned}$$

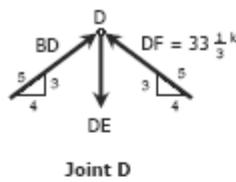

At joint D: (by symmetry)

$$BD = DF = 33\frac{1}{3}^k (C)$$

$$\sum F_V = 0$$

$$DE = \frac{3}{5}BD + \frac{3}{5}DF$$

$$\begin{aligned}&= \frac{3}{5}(33\frac{1}{3}) + \frac{3}{5}(33\frac{1}{3}) \\ &= 40^k (T)\end{aligned}$$

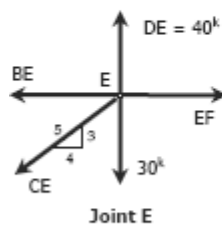

At joint E:

$$\sum F_V = 0$$

$$\frac{3}{5}CE + 30 = 40$$

$$CE = 16\frac{2}{3}^k (T)$$

Stresses:

Stress = Force/Area

$$\sigma_{CE} = \frac{16\frac{2}{3}}{1.8} = 9.26 \text{ ksi } (T)$$

$$\sigma_{DE} = \frac{40}{1.8} = 22.22 \text{ ksi } (T)$$

$$\sigma_{DF} = \frac{33\frac{1}{3}}{1.8} = 18.52 \text{ ksi } (C)$$

Problem 112

Determine the cross-sectional areas of members AG, BC, and CE for the truss shown in Fig. P-112 above. The stresses are not to exceed 20 ksi in tension and 14 ksi in compression. A reduced stress in compression is specified to reduce the danger of buckling.

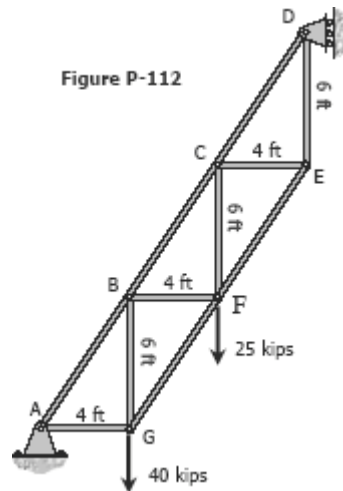

Solution 112

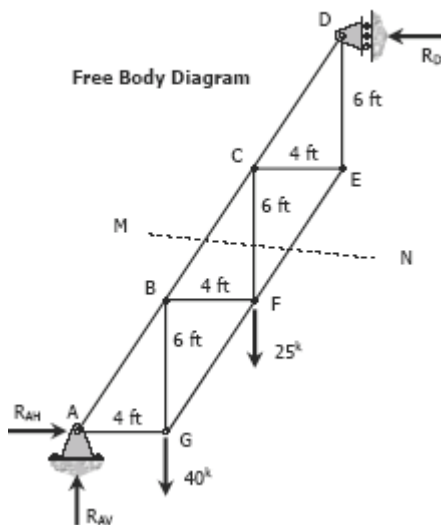

$$\begin{aligned}\sum F_V &= 0 \\ R_{AV} &= 40 + 25 \\ &= 65^k\end{aligned}$$

$$\begin{aligned}\sum M_A &= 0 \\ 18R_D &= 8(25) + 4(40) \\ R_D &= 20^k\end{aligned}$$

$$\begin{aligned}\sum F_H &= 0 \\ R_{AH} &= R_D = 20^k\end{aligned}$$

Check:

$$\begin{aligned}\sum M_D &= 0 \\ 12R_{AV} &= 18(R_{AH}) + 4(25) + 8(40) \\ 12(65) &= 18(20) + 4(25) + 8(40) \\ 780 \text{ ft}\cdot\text{kip} &= 780 \text{ ft}\cdot\text{kip} \text{ (OK!)}\end{aligned}$$

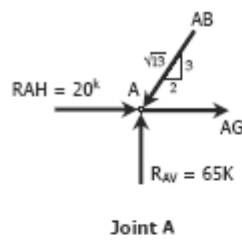

For member AG:

At joint A:

$$\sum F_V = 0$$

$$\frac{3}{\sqrt{13}} AB = 65$$

$$AB = \frac{65\sqrt{13}}{3}$$

$$= 78.12k$$

$$\sum F_H = 0$$

$$AG + 20 = \frac{2}{\sqrt{13}} AB$$

$$AG = \frac{2}{\sqrt{13}} (78.12) - 20$$

$$= 20.33k \text{ Tension}$$

$$AG = \sigma_{\text{tension}} A_{AG}$$

$$20.33 = 20 A_{AG}$$

$$A_{AG} = 1.17 \text{ in}^2$$

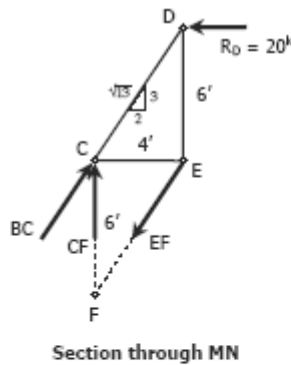

For member BC:

At section through MN

$$\sum M_F = 0$$

$$6\left(\frac{2}{\sqrt{13}} BC\right) = 12(20)$$

$$BC = 20\sqrt{13}$$

$$= 72.11k \text{ Compression}$$

$$BC = \sigma_{\text{compression}} A_{BC}$$

$$72.11 = 14 A_{BC}$$

$$A_{BC} = 5.15 \text{ in}^2$$

For member CE:

At joint D:

$$\sum F_H = 0$$

$$\frac{2}{\sqrt{13}} CD = 20$$

$$CD = 10\sqrt{13}$$

$$= 36.06k$$

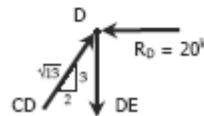

Joint D

$$\sum F_V = 0$$

$$DE = \frac{3}{\sqrt{13}} CD$$

$$= \frac{3}{\sqrt{13}} (36.06)$$

$$= 30k$$

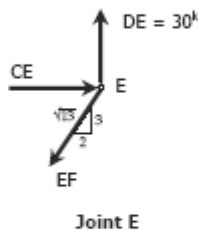

At joint E:

$$\sum F_V = 0$$

$$\frac{3}{\sqrt{13}} EF = 30$$

$$EF = 10\sqrt{13} = 36.06k$$

$$\sum F_H = 0$$

$$CE = \frac{2}{\sqrt{13}} EF$$

$$= \frac{2}{\sqrt{13}} (36.06)$$

$$= 20k \text{ Compression}$$

$$CE = \sigma_{\text{compression}} A_{CE}$$

$$20 = 14 A_{CE}$$

$$A_{CE} = 1.43 \text{ in}^2$$

Problem 113

Find the stresses in members BC, BD, and CF for the truss shown in Fig. P-113. Indicate the tension or compression. The cross sectional area of each member is 1600 mm^2 .

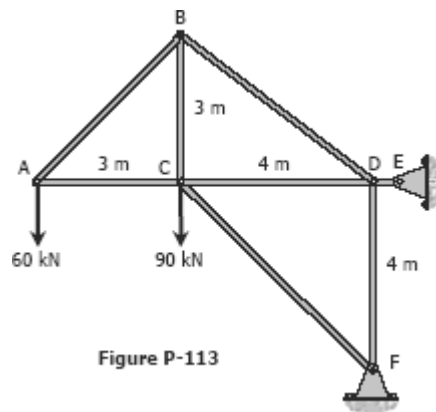
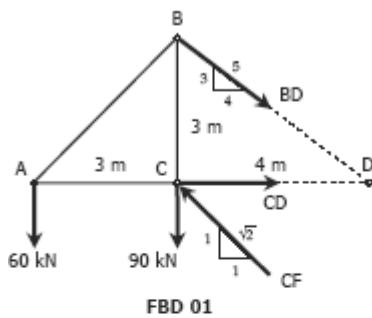

Figure P-113

Solution 113



For member BD : (See FBD 01)

$$\sum M_C = 0$$

$$3\left(\frac{4}{5}BD\right) = 3(60)$$

$$BD = 75 \text{ kN Tension}$$

$$BD = \sigma_{BD} A$$

$$75 (1000) = \sigma_{BD} (1600)$$

$$\sigma_{BD} = 46.875 \text{ MPa (Tension)}$$

For member CF : (See FBD 01)

$$\sum M_D = 0$$

$$4\left(\frac{1}{\sqrt{2}}CF\right) = 4(90) + 7(60)$$

$$CF = 195\sqrt{2}$$

$$= 275.77 \text{ kN Compression}$$

$$CF = \sigma_{CF} A$$

$$275.77 (1000) = \sigma_{CF} (1600)$$

$$\sigma_{CF} = 172.357 \text{ MPa (Compression)}$$

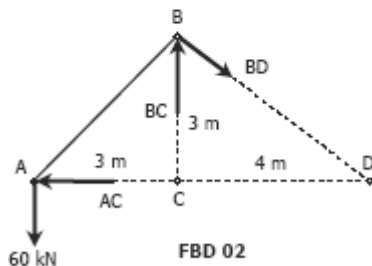

For member BC : (See FBD 02)

$$\sum M_D = 0$$

$$4BC = 7(60)$$

$$BC = 105 \text{ kN Compression}$$

$$BC = \sigma_{BC} A$$

$$105 (1000) = \sigma_{BC} (1600)$$

$$\sigma_{BC} = 65.625 \text{ MPa (Compression)}$$

Problem 114

The homogeneous bar $ABCD$ shown in Fig. P-114 is supported by a cable that runs from A to B around the smooth peg at E , a vertical cable at C , and a smooth inclined surface at D . Determine the mass of the heaviest bar that can be supported if the stress in each cable is limited to 100 MPa . The area of the cable AB is 250 mm^2 and that of the cable at C is 300 mm^2 .

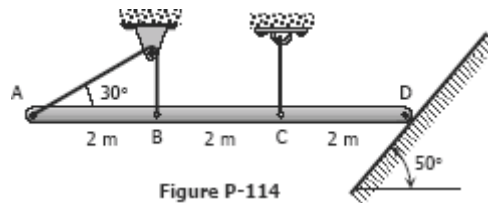
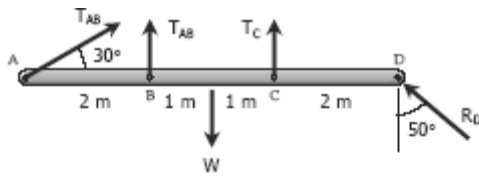

Figure P-114

Solution 114



$$\Sigma F_H = 0$$

$$T_{AB} \cos 30^\circ = R_D \sin 50^\circ$$

$$R_D = 1.1305 T_{AB}$$

$$\Sigma F_V = 0$$

$$T_{AB} \sin 30^\circ + T_{AB} + T_C + R_D \cos 50^\circ = W$$

$$T_{AB} \sin 30^\circ + T_{AB} + T_C + (1.1305 T_{AB}) \cos 50^\circ = W$$

$$2.2267 T_{AB} + T_C = W$$

$$T_C = W - 2.2267 T_{AB}$$

$$\Sigma M_D = 0$$

$$6(T_{AB} \sin 30^\circ) + 4T_{AB} + 2T_C = 3W$$

$$7T_{AB} + 2(W - 2.2267 T_{AB}) = 3W$$

$$2.5466 T_{AB} = W$$

$$T_{AB} = 0.3927 W$$

$$T_C = W - 2.2267 T_{AB}$$

$$= W - 2.2267(0.3927 W)$$

$$= 0.1256 W$$

Based on cable AB:

$$T_{AB} = \sigma_{AB} A_{AB}$$

$$0.3927 W = 100(250)$$

$$W = 63\,661.83 \text{ N}$$

Based on cable at C:

$$T_C = \sigma_C A_C$$

$$0.1256 W = 100(300)$$

$$W = 238\,853.50 \text{ N}$$

Safe weight $W = 63\,669.92 \text{ N}$

$$W = mg$$

$$63\,669.92 = m(9.81)$$

$$m = 6\,490 \text{ kg}$$

$$= 6.49 \text{ Mg}$$

Shearing Stress

Forces parallel to the area resisting the force cause shearing stress. It differs to tensile and compressive stresses, which are caused by forces perpendicular to the area on which they act. Shearing stress is also known as tangential stress.

$$\tau = \frac{V}{A}$$

where V is the resultant shearing force which passes through the centroid of the area A being sheared.

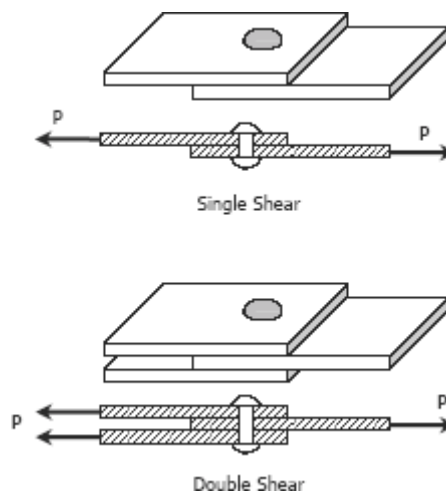

SOLVED PROBLEMS IN SHEARING STRESS

Problem 115

What force is required to punch a 20-mm-diameter hole in a plate that is 25 mm thick? The shear strength is 350 MN/m^2 .

Solution 115

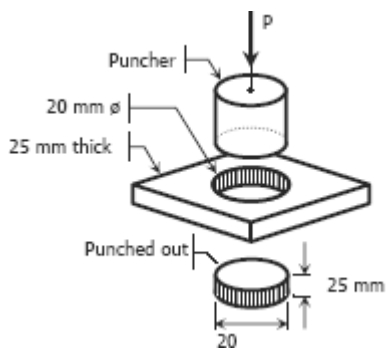

The resisting area is the shaded area along the perimeter and the shear force V is equal to the punching force P .

$$\begin{aligned} V &= \tau A \\ P &= 350[\pi(20)(25)] \\ &= 549\,778.7 \text{ N} \\ &= 549.8 \text{ kN} \end{aligned}$$

Problem 116

As in Fig. 1-11c, a hole is to be punched out of a plate having a shearing strength of 40 ksi. The compressive stress in the punch is limited to 50 ksi. **(a)** Compute the maximum thickness of plate in which a hole 2.5 inches in diameter can be punched. **(b)** If the plate is 0.25 inch thick, determine the diameter of the smallest hole that can be punched.

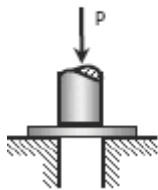

Figure 1-11c

(a) Maximum thickness of plate:

Based on puncher strength:

$$\begin{aligned} P &= \sigma A \\ &= 50 \left[\frac{1}{4} \pi (2.5)^2 \right] \\ &= 78.125\pi \text{ kips} \rightarrow \text{Equivalent shear force of the plate} \end{aligned}$$

Based on shear strength of plate:

$$\begin{aligned} V &= \tau A \quad \rightarrow V = P \\ 78.125\pi &= 40[\pi(2.5t)] \\ t &= 0.781 \text{ inch} \end{aligned}$$

(b) Diameter of smallest hole:

Based on compression of puncher:

$$\begin{aligned} P &= \sigma A \\ &= 50 \left(\frac{1}{4} \pi d^2 \right) \\ &= 12.5\pi d^2 \quad \rightarrow \text{Equivalent shear force for plate} \end{aligned}$$

Based on shearing of plate:

$$\begin{aligned} V &= \tau A \quad \rightarrow V = P \\ 12.5\pi d^2 &= 40[\pi d(0.25)] \\ d &= 0.8 \text{ in} \end{aligned}$$

Problem 117

Find the smallest diameter bolt that can be used in the clevis shown in Fig. 1-11b if $P = 400 \text{ kN}$. The shearing strength of the bolt is 300 MPa.

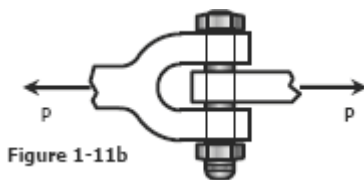

Figure 1-11b

The bolt is subject to double shear.

$$\begin{aligned} V &= \tau A \\ 400(1000) &= 300 \left[2 \left(\frac{1}{4} \pi d^2 \right) \right] \\ d &= 29.13 \text{ mm} \end{aligned}$$

Problem 118

A 200-mm-diameter pulley is prevented from rotating relative to 60-mm-diameter shaft by a 70-mm-long key, as shown in Fig. P-118. If a torque $T = 2.2 \text{ kN}\cdot\text{m}$ is applied to the shaft, determine the width b if the allowable shearing stress in the key is 60 MPa.

Figure P-118

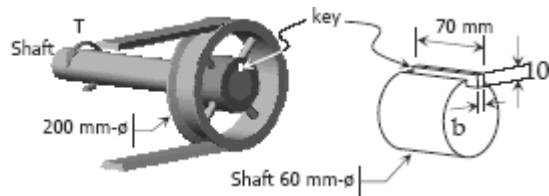

Solution 118

$$T = 0.03F$$

$$2.2 = 0.03F$$

$$F = 73.33 \text{ kN}$$

$$V = \tau A$$

Where: $V = F = 73.33 \text{ kN}$
 $A = 70b$; $\tau = 60 \text{ MPa}$

$$73.33(1000) = 60(70b)$$

$$b = 17.46 \text{ mm}$$

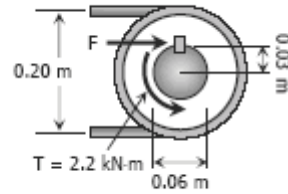
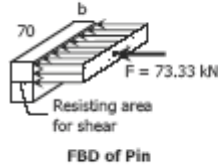

Problem 119

Compute the shearing stress in the pin at B for the member supported as shown in Fig. P-119. The pin diameter is 20 mm.

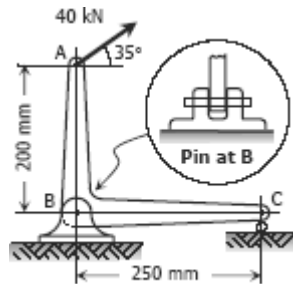

Figure P-119

Solution 119

From the FBD:

$$\Sigma M_C = 0$$

$$0.25R_{BV} = 0.25(40 \sin 35^\circ) + 0.2(40 \cos 35^\circ)$$

$$R_{BV} = 49.156 \text{ kN}$$

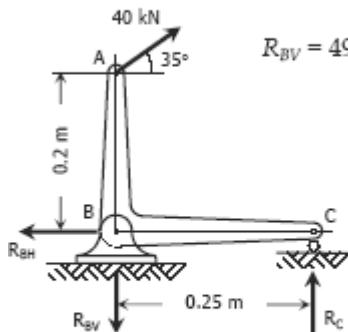

Free Body Diagram

$$\Sigma F_H = 0$$

$$R_{BH} = 40 \cos 35^\circ = 32.766 \text{ kN}$$

$$R_B = \sqrt{R_{BH}^2 + R_{BV}^2} = \sqrt{32.766^2 + 49.156^2} = 59.076 \text{ kN} \rightarrow \text{shear force of pin at B}$$

$$V_B = \tau_B A \rightarrow \text{double shear}$$

$$59.076 (1000) = \tau_B [2[\frac{1}{4}\pi(20^2)]]$$

$$\tau_B = 94.02 \text{ MPa}$$

Problem 120

The members of the structure in Fig. P-120 weigh 200 lb/ft. Determine the smallest diameter pin that can be used at A if the shearing stress is limited to 5000 psi. Assume single shear.

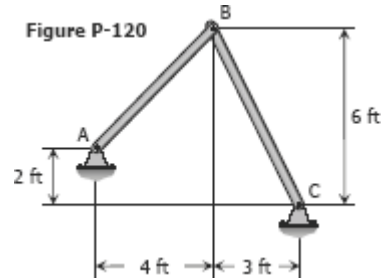

Solution 120

For member AB:

$$\text{Length, } L_{AB} = \sqrt{4^2 + 4^2} \\ = 5.66 \text{ ft}$$

$$\text{Weight, } W_{AB} = 5.66(200) \\ = 1132 \text{ lb}$$

$$\Sigma M_A = 0$$

$$4R_{BH} + 4R_{BV} = 2W_{AB}$$

$$4R_{BH} + 4R_{BV} = 2(1132)$$

$$R_{BH} + R_{BV} = 566 \quad \rightarrow (1)$$

For member BC:

$$\text{Length, } L_{BC} = \sqrt{3^2 + 6^2} \\ = 6.71 \text{ ft}$$

$$\text{Weight, } W_{BC} = 6.71(200) \\ = 1342 \text{ lb}$$

$$\Sigma M_C = 0$$

$$6R_{BH} = 1.5W_{BC} + 3R_{BV}$$

$$6R_{BH} - 3R_{BV} = 1.5(1342)$$

$$2R_{BH} - R_{BV} = 671 \quad \rightarrow (2)$$

Add equations (1) and (2)

$$R_{BH} + R_{BV} = 566 \quad \rightarrow (1)$$

$$2R_{BH} - R_{BV} = 671 \quad \rightarrow (2)$$

$$\frac{3R_{BH}}{\quad} = 1237$$

$$R_{BH} = 412.33 \text{ lb}$$

From equation (1):

$$412.33 + R_{BV} = 566$$

$$R_{BV} = 153.67 \text{ lb}$$

From the FBD of member AB

$$\Sigma F_H = 0$$

$$R_{AH} = R_{BH} = 412.33 \text{ lb}$$

$$\Sigma F_V = 0$$

$$R_{AV} + R_{BV} = W_{AB}$$

$$R_{AV} + 153.67 = 1132$$

$$R_{AV} = 978.33 \text{ lb}$$

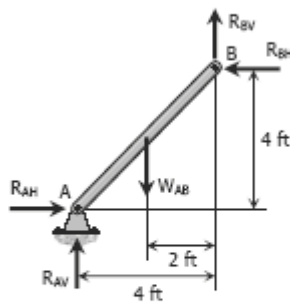

FBD of member

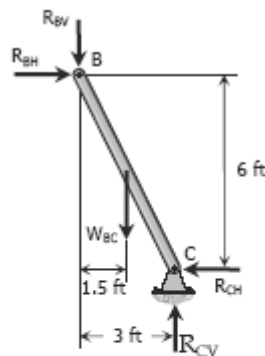

FBD of member BC

$$\begin{aligned}
 R_A &= \sqrt{R_{AH}^2 + R_{AV}^2} \\
 &= \sqrt{412.33^2 + 978.33^2} \\
 &= 1061.67 \text{ lb} \rightarrow \text{shear force of pin at A}
 \end{aligned}$$

$$\begin{aligned}
 V &= \tau A \\
 1061.67 &= 5000 \left(\frac{1}{4} \pi d^2 \right) \\
 d &= 0.520 \text{ in}
 \end{aligned}$$

Problem 121

Referring to Fig. P-121, compute the maximum force P that can be applied by the machine operator, if the shearing stress in the pin at B and the axial stress in the control rod at C are limited to 4000 psi and 5000 psi, respectively. The diameters are 0.25 inch for the pin, and 0.5 inch for the control rod. Assume single shear for the pin at B.

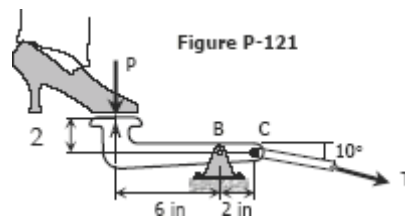

Solution 121

$$[\Sigma M_B = 0] \quad 6P = 2T \sin 10^\circ \rightarrow (1)$$

$$\begin{aligned}
 [\Sigma F_H = 0] \quad B_H &= T \cos 10^\circ \rightarrow \text{from (1), } T = 3P / \sin 10^\circ \\
 B_H &= (3P / \sin 10^\circ) \cos 10^\circ \\
 B_H &= 3 \cot 10^\circ P
 \end{aligned}$$

$$\begin{aligned}
 [\Sigma F_V = 0] \quad B_V &= T \sin 10^\circ + P \rightarrow \text{from (1), } T \sin 10^\circ = 3P \\
 B_V &= 3P + P \\
 B_V &= 4P
 \end{aligned}$$

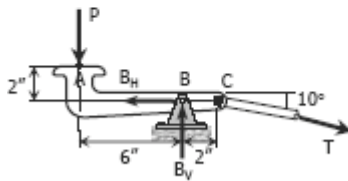

$$\begin{aligned}
 R_B^2 &= B_H^2 + B_V^2 \\
 R_B^2 &= (3 \cot 10^\circ P)^2 + (4P)^2 \\
 R_B^2 &= 305.47P^2 \\
 R_B &= 17.48P \\
 P &= R_B / 17.48 \rightarrow (2)
 \end{aligned}$$

Based on tension of rod (equation 1):

$$\begin{aligned}
 P &= \frac{1}{3} T \sin 10^\circ \\
 P &= \frac{1}{3} [5000 \times \frac{1}{4} \pi (0.5)^2] \sin 10^\circ \\
 P &= 56.83 \text{ lb}
 \end{aligned}$$

Based on shear of rivet (equation 2):

$$\begin{aligned}
 P &= 4000 \times \frac{1}{4} \pi (0.25)^2 / 17.48 \\
 P &= 11.23 \text{ lb}
 \end{aligned}$$

Safe load $P = 11.23 \text{ lb}$

Problem 122

Two blocks of wood, width w and thickness t , are glued together along the joint inclined at the angle θ as shown in Fig. P-122. Using the free-body diagram concept in Fig. 1-4a, show that the shearing stress on the glued joint is $\tau = P \sin 2\theta / 2A$, where A is the cross-sectional area.

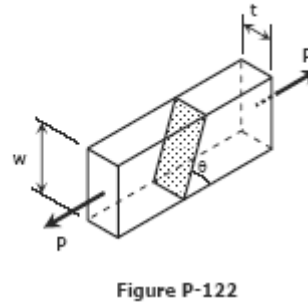
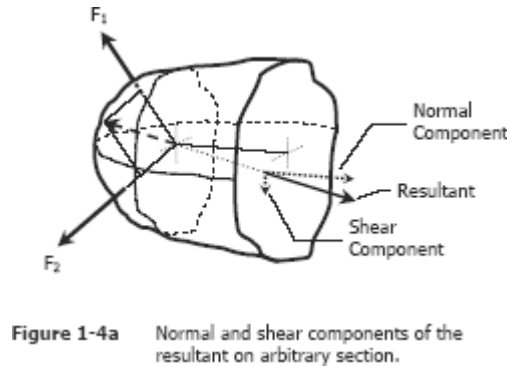

Solution 122

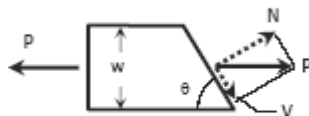

$$\begin{aligned} \text{Shear area, } A_{\text{shear}} &= t (w \csc \theta) \\ &= tw \csc \theta \\ &= A \csc \theta \end{aligned}$$

$$\text{Shear force, } V = P \cos \theta$$

$$\begin{aligned} V &= \tau A_{\text{shear}} \\ P \cos \theta &= \tau (A \csc \theta) \\ \tau &= P \sin \theta \cos \theta / A \\ &= P (2 \sin \theta \cos \theta) / 2A \\ &= P \sin 2\theta / 2A \quad (\text{ok!}) \end{aligned}$$

Problem 123

A rectangular piece of wood, 50 mm by 100 mm in cross section, is used as a compression block shown in Fig. P-123. Determine the axial force P that can be safely applied to the block if the compressive stress in wood is limited to 20 MN/m^2 and the shearing stress parallel to the grain is limited to 5 MN/m^2 . The grain makes an angle of 20° with the horizontal, as shown. (Hint: Use the results in Problem 122.)

Solution 123

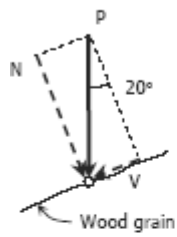

Based on maximum compressive stress:

Normal force:

$$N = P \cos 20^\circ$$

Normal area:

$$A_N = 50 (\sec 20^\circ) \\ = 5320.89 \text{ mm}^2$$

$$N = \sigma A_N$$

$$P \cos 20^\circ = 20 (5320.89)$$

$$P = 113\,247 \text{ N}$$

$$= 113.25 \text{ kN}$$

Based on maximum shearing stress:

Shear force:

$$V = P \sin 20^\circ$$

Shear area:

$$A_V = A_N \\ = 5320.89 \text{ mm}^2$$

$$V = \tau A_V$$

$$P \sin 20^\circ = 5 (5320.89)$$

$$P = 77\,786 \text{ N}$$

$$= 77.79 \text{ kN}$$

For safe compressive force, use $P = 77.79 \text{ kN}$

Bearing Stress

Bearing stress is the contact pressure between the separate bodies. It differs from compressive stress, as it is an internal stress caused by compressive forces.

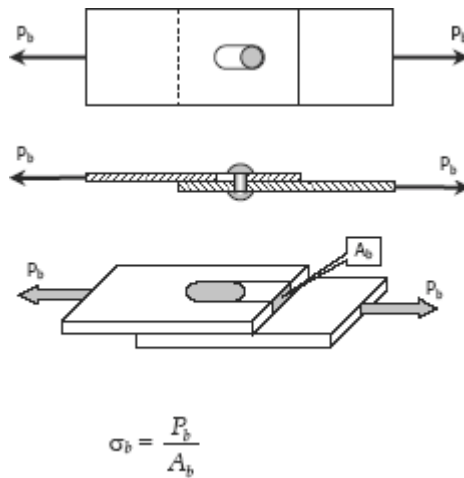

SOLVED PROBLEMS IN BEARING STRESS

Problem 125

In Fig. 1-12, assume that a 20-mm-diameter rivet joins the plates that are each 110 mm wide. The allowable stresses are 120 MPa for bearing in the plate material and 60 MPa for shearing of rivet. Determine (a) the minimum thickness of each plate; and (b) the largest average tensile stress in the plates.

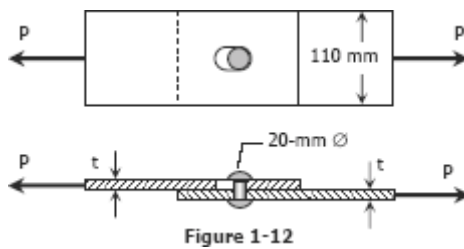

Solution 125

(a) From shearing of rivet:

$$\begin{aligned} P &= \tau A_{\text{rivets}} \\ &= 60 \left[\frac{1}{4} \pi (20^2) \right] \\ &= 6000\pi \text{ N} \end{aligned}$$

From bearing of plate material:

$$\begin{aligned} P &= \sigma_b A_b \\ 6000\pi &= 120(20t) \\ t &= 7.85 \text{ mm} \end{aligned}$$

(b) Largest average tensile stress in the plate:

$$\begin{aligned} P &= \sigma A \\ 6000\pi &= \sigma [7.85(110 - 20)] \\ \sigma &= 26.67 \text{ MPa} \end{aligned}$$

Problem 126

The lap joint shown in Fig. P-126 is fastened by four $\frac{3}{4}$ -in.-diameter rivets. Calculate the maximum safe load P that can be applied if the shearing stress in the rivets is limited to 14 ksi and the bearing stress in the plates is limited to 18 ksi. Assume the applied load is uniformly distributed among the four rivets.

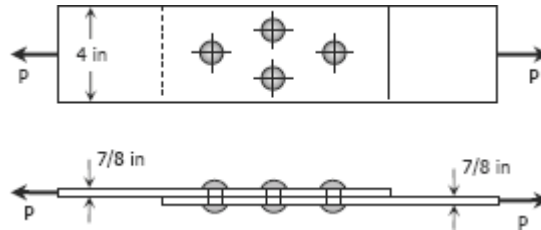

Solution 126

Based on shearing of rivets:

$$P = \tau A$$

$$P = 14 \left[4 \left(\frac{1}{4} \pi \right) \left(\frac{3}{4} \right)^2 \right]$$

$$P = 24.74 \text{ kips}$$

Based on bearing of plates:

$$P = \sigma_b A_b$$

$$P = 18 \left[4 \left(\frac{3}{4} \right) \left(\frac{7}{8} \right) \right]$$

$$P = 47.25 \text{ kips}$$

Safe load $P = 24.74 \text{ kips}$

Problem 127

In the clevis shown in Fig. 1-11b, find the minimum bolt diameter and the minimum thickness of each yoke that will support a load $P = 14 \text{ kips}$ without exceeding a shearing stress of 12 ksi and a bearing stress of 20 ksi.

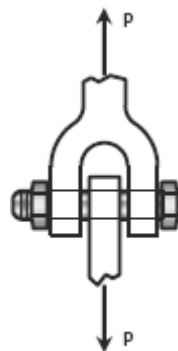
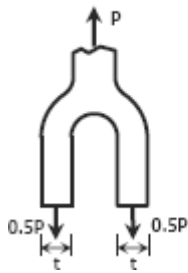

Figure 1-11b

Solution 127



For shearing of rivets (double shear)

$$P = \tau A$$

$$14 = 12[2(\frac{1}{4}\pi d^2)]$$

$$d = 0.8618 \text{ in} \rightarrow \text{diameter of bolt}$$

For bearing of yoke:

$$P = \sigma_b A_b$$

$$14 = 20[2(0.8618t)]$$

$$t = 0.4061 \text{ in} \rightarrow \text{thickness of yoke}$$

Problem 128

A W18 × 86 beam is riveted to a W24 × 117 girder by a connection similar to that in Fig. 1-13. The diameter of the rivets is 7/8 in., and the angles are each 4 × 3 1/2 × 3/8 in. For each rivet, assume that the allowable stresses are $\tau = 15$ ksi and $\sigma_b = 32$ ksi.

Find the allowable

load on the connection.

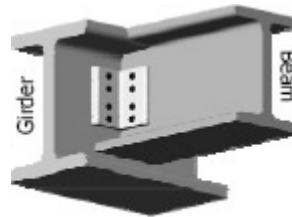

Figure 1-13

Solution 128

Note: Textbook is Strength of Materials 4th edition by Pytel and Singer

Relevant data from the table (Appendix B of textbook): *Properties of Wide-Flange Sections (W shapes): U.S. Customary Units*

Designation	Web thickness
W18 × 86	0.480 in
W24 × 117	0.550 in

Shearing strength of rivets:

There are 8 single-shear rivets in the girder and 4 double-shear (equivalent to 8 single-shear) in the beam, thus, the shear strength of rivets in girder and beam are equal.

$$V = \tau A = 15 \left[\frac{1}{4} \pi \left(\frac{7}{8} \right)^2 (8) \right]$$

$$V = 72.16 \text{ kips}$$

Bearing strength on the girder:

The thickness of girder W24 × 117 is 0.550" while that of the angle clip $L4 \times 3\frac{1}{2} \times \frac{3}{8}$ is $\frac{3}{8}$ " or 0.375", thus, the critical in bearing is the clip.

$$P = \sigma_b A_b = 32 \left[\frac{7}{8} (0.375)(8) \right]$$

$$P = 84 \text{ kips}$$

Bearing strength on the beam:

The thickness of beam W18 × 86 is 0.480" while that of the clip angle is $2 \times 0.375" = 0.75"$ (clip angles are on both sides of the beam), thus, the critical in bearing is the beam.

$$P = \sigma_b A_b = 32 \left[\frac{7}{8} (0.480)(4) \right]$$

$$P = 53.76 \text{ kips}$$

The allowable load on the connection is $P = 53.76 \text{ kips}$

Problem 129

A 7/8-in.-diameter bolt, having a diameter at the root of the threads of 0.731 in., is used to fasten two timbers together as shown in Fig. P-129. The nut is tightened to cause a tensile stress of 18 ksi in the bolt. Compute the shearing stress in the head of the bolt and in the threads. Also, determine the outside diameter of the washers if their inside diameter is 9/8 in. and the bearing stress is limited to 800 psi.

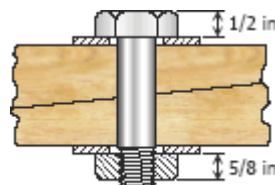
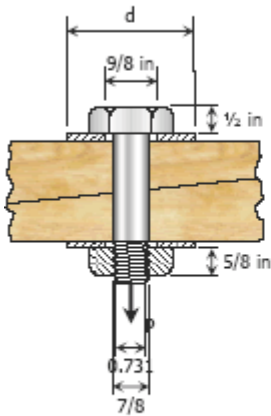

Figure P-127

Solution 129



Tensile force on the bolt:
 $P = \sigma A = 18 \left[\frac{1}{4} \pi \left(\frac{7}{8} \right)^2 \right]$
 $P = 10.82 \text{ kips}$

Shearing stress in the head of the bolt:
 $\tau = \frac{P}{A} = \frac{10.82}{\pi \left(\frac{7}{8} \right) \left(\frac{1}{2} \right)}$
 $\tau = 7.872 \text{ ksi}$

Shearing stress in the threads:
 $\tau = \frac{P}{A} = \frac{10.82}{\pi (0.731) \left(\frac{5}{8} \right)}$
 $\tau = 7.538 \text{ ksi}$



Outside diameter of washer
 $P = \sigma_b A_b$
 $10.82(1000) = 800 \left[\frac{1}{4} \pi \left[d^2 - \left(\frac{9}{8} \right)^2 \right] \right]$
 $d = 4.3 \text{ in}$

Problem 130

Figure P-130 shows a roof truss and the detail of the riveted connection at joint B. Using allowable stresses of $\tau = 70 \text{ MPa}$ and $\sigma_b = 140 \text{ MPa}$, how many 19-mm diameter rivets are required to fasten member BC to the gusset plate? Member BE? What is the largest average tensile or compressive stress in BC and BE?

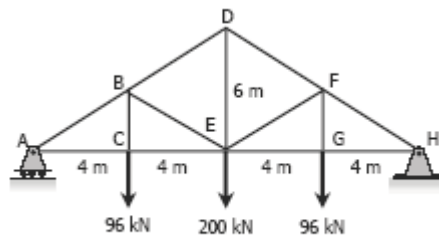
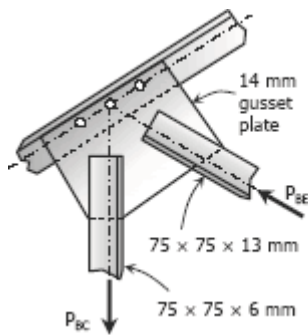
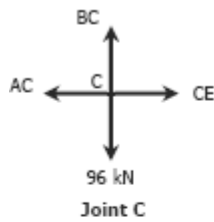

Figure P-130 and P-131

Solution 130



At Joint C:
 $\sum F_V = 0$
 $BC = 96 \text{ kN}$ (Tension)

Consider the section through member BD, BE, and CE:

$\sum M_A = 0$
 $8\left(\frac{3}{5} BE\right) = 4(96)$
 $BE = 80 \text{ kN}$ (Compression)

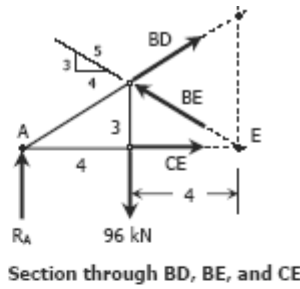

For Member BC:
 Based on shearing of rivets:
 $BC = \tau A$
 Where $A = \text{area of 1 rivet} \times \text{number of rivets, } n$
 $96\,000 = 70\left[\frac{1}{4} \pi(19^2)n\right]$
 $n = 4.8$ say 5 rivets

Based on bearing of member:
 $BC = \sigma_b A_b$
 Where $A_b = \text{diameter of rivet} \times \text{thickness of BC} \times \text{number of rivets, } n$
 $96\,000 = 140[19(6)n]$
 $n = 6.02$ say 7 rivets

use 7 rivets for member BC

For member BE:
 Based on shearing of rivets:
 $BE = \tau A$
 Where $A = \text{area of 1 rivet} \times \text{number of rivets, } n$
 $80\,000 = 70\left[\frac{1}{4} \pi(19^2)n\right]$
 $n = 4.03$ say 5 rivets

Based on bearing of member:
 $BE = \sigma_b A_b$
 Where $A_b = \text{diameter of rivet} \times \text{thickness of BE} \times \text{number of rivets, } n$
 $80\,000 = 140[19(13)n]$
 $n = 2.3$ say 3 rivets

use 5 rivets for member BE

Relevant data from the table (Appendix B of textbook): *Properties of Equal Angle Sections: SI Units*

Designation	Area
L75 × 75 × 6	864 mm ²
L75 × 75 × 13	1780 mm ²

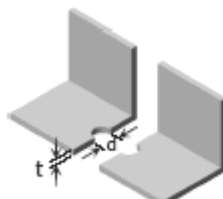

$t = \text{thickness of member}$
 $d = \text{diameter of rivet hole}$

Note:
 $A = \text{Area} - dt$

Tensile stress of member BC (L75 × 75 × 6):

$$\sigma = \frac{P}{A} = \frac{96(1000)}{864 - 19(6)}$$

$$\sigma = 128 \text{ Mpa}$$

Compressive stress of member BE (L75 × 75 × 13):

$$\sigma = \frac{P}{A} = \frac{80(1000)}{1780}$$

$$\sigma = 44.94 \text{ Mpa}$$

Problem 131

Repeat Problem 130 if the rivet diameter is 22 mm and all other data remain unchanged.

Solution 131

For member BC:

$$P = 96 \text{ kN (Tension)}$$

Based on shearing of rivets:

$$P = \tau A$$

$$96\,000 = 70 \left[\frac{1}{4} \pi (22^2) n \right]$$

$$n = 3.6 \text{ say } 4 \text{ rivets}$$

Based on bearing of member:

$$P = \sigma_b A_b$$

$$96\,000 = 140 [22(6)n]$$

$$n = 5.2 \text{ say } 6 \text{ rivets}$$

Use 6 rivets for member BC

Tensile stress:

$$\sigma = \frac{P}{A} = \frac{96(1000)}{864 - 22(6)}$$

$$\sigma = 131.15 \text{ MPa}$$

For member BE:

$$P = 80 \text{ kN (Compression)}$$

Based on shearing of rivets:

$$P = \tau A$$

$$80\,000 = 70 \left[\frac{1}{4} \pi (22^2) n \right]$$

$$n = 3.01 \text{ say } 4 \text{ rivets}$$

Based on bearing of member:

$$P = \sigma_b A_b$$

$$80\,000 = 140 [22(13)n]$$

$$n = 1.998 \text{ say } 2 \text{ rivets}$$

use 4 rivets for member BE

Compressive stress:

$$\sigma = \frac{P}{A} = \frac{80(1000)}{1780}$$

$$\sigma = 44.94 \text{ MPa}$$

Thin-Walled Pressure Vessels

A tank or pipe carrying a fluid or gas under a pressure is subjected to tensile forces, which resist bursting, developed across longitudinal and transverse sections.

TANGENTIAL STRESS

(Circumferential Stress)

Consider the tank shown being subjected to an internal pressure p . The length of the tank is L and the wall thickness is t . Isolating the right half of the tank:

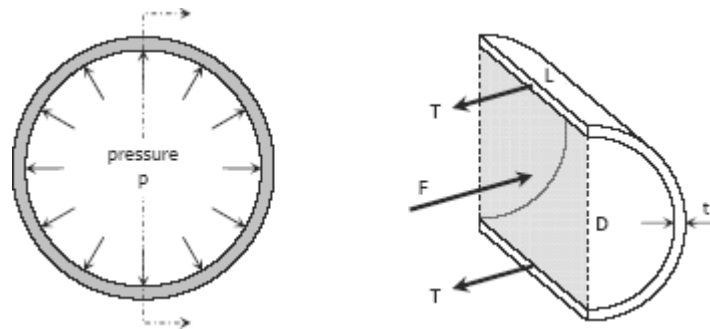

$$\begin{aligned}
 F &= pA = pDL \\
 T &= \sigma_t A_{\text{wall}} = \sigma_t tL \\
 [\Sigma F_H = 0] \\
 F &= 2T \\
 pDL &= 2(\sigma_t tL) \\
 \sigma_t &= \frac{pD}{2t}
 \end{aligned}$$

If there exist an external pressure p_o and an internal pressure p_i , the formula may be expressed as:

$$\sigma_t = \frac{(p_i - p_o)D}{2t}$$

LONGITUDINAL STRESS, σ_L

Consider the free body diagram in the transverse section of the tank:

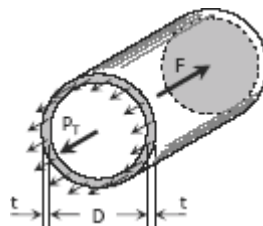

The total force acting at the rear of the tank F must equal to the total longitudinal stress on the wall $P_T = \sigma_L A_{\text{wall}}$. Since t is so small compared to D , the area of the wall is close to πDt

$$F = pA = p \frac{\pi}{4} D^2$$

$$P_T = \sigma_L \pi D t$$

$$[\Sigma F_H = 0]$$

$$P_T = F$$

$$\sigma_L \pi D t = p \frac{\pi}{4} D^2$$

$$\sigma_L = \frac{pD}{4t}$$

If there exist an external pressure p_o and an internal pressure p_i , the formula may be expressed as:

$$\sigma_L = \frac{(p_i - p_o)D}{4t}$$

It can be observed that the tangential stress is twice that of the longitudinal stress.

$$\sigma_t = 2 \sigma_L$$

SPHERICAL SHELL

If a spherical tank of diameter D and thickness t contains gas under a pressure of p , the stress at the wall can be expressed as:

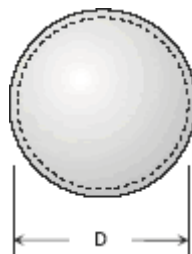

$$\sigma_L = \frac{(p_i - p_o)D}{4t}$$

SOLVED PROBLEMS IN THIN WALLED PREASSURE VESSELS

Problem 133

A cylindrical steel pressure vessel 400 mm in diameter with a wall thickness of 20 mm, is subjected to an internal pressure of 4.5 MN/m². (a) Calculate the tangential and longitudinal stresses in the steel. (b) To what value may the internal pressure be increased if the stress in the steel is limited to 120 MN/m²? (c) If the internal pressure were increased until the vessel burst, sketch the type of fracture that would occur.

Solution 133

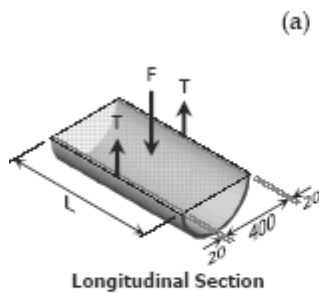

(a) Tangential stress (longitudinal section):

$$F = 2T$$

$$pDL = 2(\sigma_t tL)$$

$$\sigma_t = \frac{pD}{2t} = \frac{4.5(400)}{2(20)}$$

$$\sigma_t = 45 \text{ MPa}$$

Longitudinal Stress (transverse section):

$$F = P$$

$$\frac{1}{4} \pi D^2 p = \sigma_l (\pi D t)$$

$$\sigma_l = \frac{pD}{4t} = \frac{4.5(400)}{4(20)}$$

$$\sigma_l = 22.5 \text{ MPa}$$

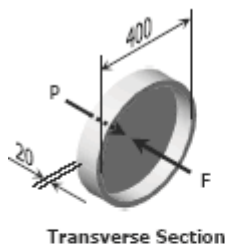

(b) From (a), $\sigma_t = \frac{pD}{2t}$ and $\sigma_l = \frac{pD}{4t}$ thus, $\sigma_t = 2\sigma_l$, this shows that tangential stress is the critical.

$$\sigma_t = \frac{pD}{2t}$$

$$120 = \frac{p(400)}{2(20)}$$

$$P = 12 \text{ MPa}$$

(c) The bursting force will cause a stress on the longitudinal section that is twice to that of the transverse section. Thus, fracture is expected as shown.

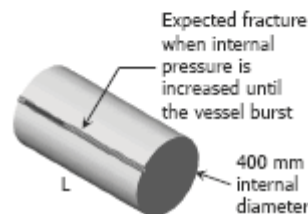

Problem 134

The wall thickness of a 4-ft-diameter spherical tank is 5/16 in. Calculate the allowable internal pressure if the stress is limited to 8000 psi.

Solution 134

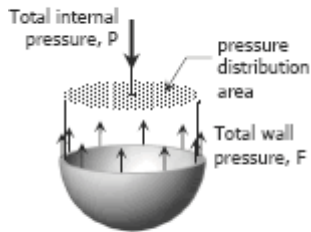

Total internal pressure:

$$P = p \left(\frac{1}{4} \pi D^2 \right)$$

Resisting wall:

$$F = P$$

$$\sigma A = p \left(\frac{1}{4} \pi D^2 \right)$$

$$\sigma (\pi D t) = p \left(\frac{1}{4} \pi D^2 \right)$$

$$\sigma = \frac{pD}{4t}$$

$$8000 = \frac{p(4 \times 12)}{4 \left(\frac{5}{16} \right)}$$

$$p = 208.33 \text{ psi}$$

Problem 135

Calculate the minimum wall thickness for a cylindrical vessel that is to carry a gas at a pressure of 1400 psi. The diameter of the vessel is 2 ft, and the stress is limited to 12 ksi.

Solution 135

The critical stress is the tangential stress

$$\sigma_t = \frac{pD}{2t}$$

$$12\,000 = \frac{1\,400(2 \times 12)}{2t}$$

$$t = 1.4 \text{ in}$$

Problem 136

A cylindrical pressure vessel is fabricated from steel plating that has a thickness of 20 mm. The diameter of the pressure vessel is 450 mm and its length is 2.0 m. Determine the maximum internal pressure that can be applied if the longitudinal stress is limited to 140 MPa, and the circumferential stress is limited to 60 MPa.

Solution 136

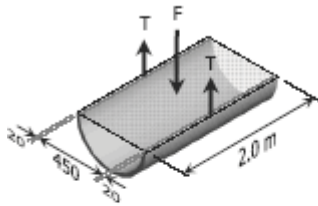

Based on circumferential stress (tangential):

$$\sum F_V = 0$$

$$F = 2T$$

$$p(DL) = 2(\sigma_t Lt)$$

$$\sigma_t = \frac{pD}{2t}$$

$$60 = \frac{p(450)}{2(20)}$$

$$p = 5.33 \text{ MPa}$$

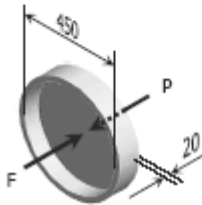

Based on longitudinal stress:

$$\sum F_H = 0$$

$$F = P$$

$$p\left(\frac{1}{4}\pi D^2\right) = \sigma_t(\pi Dt)$$

$$\sigma_t = \frac{pD}{4t}$$

$$140 = \frac{p(450)}{4(20)}$$

$$p = 24.89 \text{ MPa}$$

Use $p = 5.33 \text{ MPa}$

Problem 137

A water tank, 22 ft in diameter, is made from steel plates that are 1/2 in. thick. Find the maximum height to which the tank may be filled if the circumferential stress is limited to 6000 psi. The specific weight of water is 62.4 lb/ft³.

Solution 137

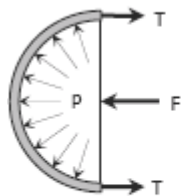

$$\begin{aligned}\sigma_t &= 6000 \text{ psi} \\ \sigma_t &= \frac{6000 \text{ lb}}{\text{in}^2} \left(\frac{12 \text{ in}}{\text{ft}} \right)^2 \\ \sigma_t &= 864\,000 \text{ lb/ft}^2\end{aligned}$$

Assuming pressure distribution to be uniform:

$$\begin{aligned}p &= \gamma h = 62.4h \\ F &= pA = 62.4h(Dh) \\ F &= 62.4(22)h^2 \\ F &= 1372.8h^2\end{aligned}$$

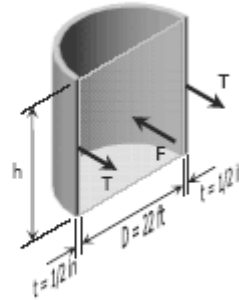

$$\begin{aligned}T &= \sigma_t A_t = 864\,000(th) \\ T &= 864\,000 \left(\frac{1}{2} \times \frac{1}{12} \right) h \\ T &= 36\,000h\end{aligned}$$

$$\begin{aligned}\Sigma F &= 0 \\ F &= 2T \\ 1372.8h^2 &= 2(36\,000h) \\ h &= 52.45 \text{ ft}\end{aligned}$$

Comment:

Given a free surface of water, the actual pressure distribution on the vessel is not uniform. It varies linearly from 0 at the free surface to γh at the bottom (see figure below). Using this actual pressure

distribution, the total hydrostatic pressure is reduced by 50%. This reduction of force will take our design into critical situation, giving us a maximum height of 200% more than the h above.

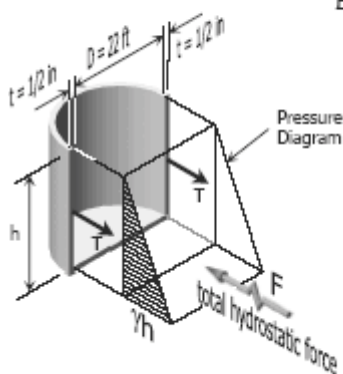

Based on actual pressure distribution:

$$\begin{aligned}\text{Total hydrostatic force, } F &: \\ F &= \text{volume of pressure diagram} \\ F &= \frac{1}{2} (\gamma h^2) D = \frac{1}{2} (62.4h^2)(22) \\ F &= 686.4h^2\end{aligned}$$

$$\begin{aligned}\Sigma M_A &= 0 \\ 2T \left(\frac{1}{2} h \right) - F \left(\frac{1}{3} h \right) &= 0 \\ T &= \frac{1}{3} F\end{aligned}$$

$$\sigma_t (ht) = \frac{1}{3} (686.4h^2)$$

$$\begin{aligned}h &= \frac{3\sigma_t t}{686.4} = \frac{3(864\,000) \left(\frac{1}{2} \times \frac{1}{12} \right)}{686.4} \\ h &= 157.34 \text{ ft}\end{aligned}$$

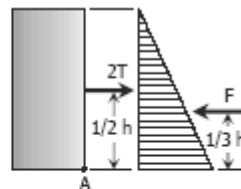

Problem 138

The strength of longitudinal joint in Fig. 1-17 is 33 kips/ft, whereas for the girth is 16 kips/ft. Calculate the maximum diameter of the cylinder tank if the internal pressure is 150 psi.

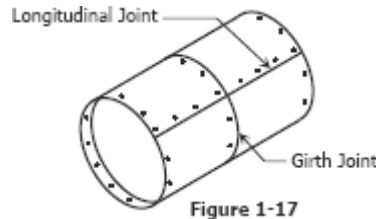

Figure 1-17

Solution 138

Internal pressure, p :

$$p = 150 \text{ psi} = \frac{150 \text{ lb}}{\text{in}^2} \left(\frac{12 \text{ in}}{\text{ft}} \right)^2$$

$$p = 21\,600 \text{ lb/ft}^2$$

For longitudinal joint (tangential stress):

Consider 1 ft length

$$F = 2T$$

$$pD = 2\sigma_t t$$

$$\sigma_t = \frac{pD}{2t}$$

$$\frac{33\,000}{t} = \frac{21\,600 D}{2t}$$

$$D = 3.06 \text{ ft} = 36.67 \text{ in}$$

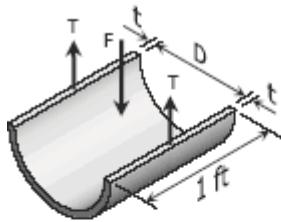

For girth joint (longitudinal stress):

$$F = P$$

$$p \left(\frac{1}{4} \pi D^2 \right) = \sigma_l (\pi D t)$$

$$\sigma_l = \frac{pD}{4t}$$

$$\frac{16\,000}{t} = \frac{21\,600 D}{4t}$$

$$D = 2.96 \text{ ft} = 35.56 \text{ in}$$

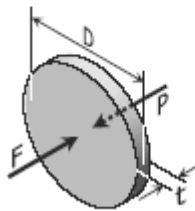

Use the smaller diameter, $D = 35.56 \text{ in}$.

Problem 139

Find the limiting peripheral velocity of a rotating steel ring if the allowable stress is 20 ksi and steel weighs 490 lb/ft³. At what revolutions per minute (rpm) will the stress reach 30 ksi if the mean radius is 10 in.?

Solution 139

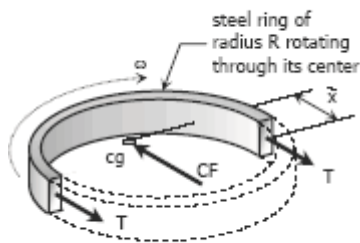

FBD of Ring in Rotation

Centrifugal Force, CF:

$$CF = M\omega^2\bar{x}$$

$$\text{where: } M = \frac{W}{g} = \frac{\gamma V}{g} = \frac{\gamma \pi R A}{g}$$

$$\omega = v/R$$

$$\bar{x} = 2R/\pi$$

$$CF = \frac{\gamma \pi R A}{g} \left(\frac{v}{R}\right)^2 \left(\frac{2R}{\pi}\right)$$

$$CF = \frac{2\gamma A v^2}{g}$$

$$2T = CF$$

$$2\sigma A = \frac{2\gamma A v^2}{g}$$

$$\sigma = \frac{\gamma v^2}{g}$$

From the given data:

$$\sigma = 20 \text{ ksi} = (20\,000 \text{ lb/in}^2)(12 \text{ in/ft})^2$$

$$\sigma = 2\,880\,000 \text{ lb/ft}^2$$

$$\gamma = 490 \text{ lb/ft}^3$$

$$2\,880\,000 = \frac{490v^2}{32.2}$$

$$v = 435.04 \text{ ft/sec}$$

When $\sigma = 30 \text{ ksi}$, and $R = 10 \text{ in}$

$$\sigma = \frac{\gamma v^2}{g}$$

$$30\,000(12^2) = \frac{490v^2}{32.2}$$

$$v = 532.81 \text{ ft/sec}$$

$$\omega = v/R = \frac{532.81}{10/12}$$

$$\omega = 639.37 \text{ rad/sec}$$

$$\omega = \frac{639.37 \text{ rad}}{\text{sec}} \times \frac{1 \text{ rev}}{2\pi \text{ rad}} \times \frac{60 \text{ sec}}{1 \text{ min}}$$

$$\omega = 6,105.54 \text{ rpm}$$

Problem 140

At what angular velocity will the stress of the rotating steel ring equal 150 MPa if its mean radius is 220 mm? The density of steel 7.85 Mg/m³.

Solution 140

$$CF = M\omega^2 \bar{x}$$

Where: $M = \rho V = \rho A \pi R$
 $\bar{x} = 2R/\pi$

$$CF = \rho A \pi R \omega^2 (2R/\pi)$$

$$CF = 2\rho A R^2 \omega^2$$

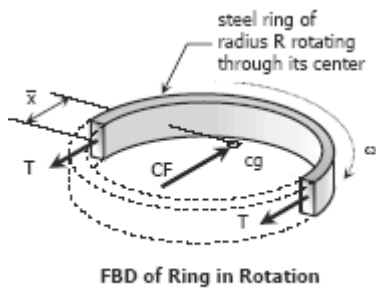

$$2T = CF$$

$$2\sigma A = 2\rho A R^2 \omega^2$$

$$\sigma = \rho R^2 \omega^2$$

From the given (Note: 1 N = 1 kg-m/sec²):

$$\sigma = 150 \text{ MPa}$$

$$= 150\,000\,000 \text{ kg-m/sec}^2\text{-m}^2$$

$$= 150\,000\,000 \text{ kg/m-sec}^2$$

$$\rho = 7.85 \text{ Mg/m}^3 = 7850 \text{ kg/m}^3$$

$$R = 220 \text{ mm} = 0.22 \text{ m}$$

$$150\,000\,000 = 7850(0.22)^2 \omega^2$$

$$\omega = 628.33 \text{ rad/sec}$$

Problem 141

The tank shown in Fig. P-141 is fabricated from 1/8-in steel plate. Calculate the maximum longitudinal and circumferential stress caused by an internal pressure of 125 psi.

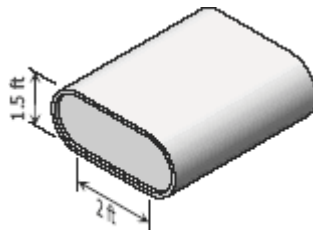
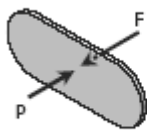

Figure P-141

Solution 141



See dimensions in Fig. P-141, thickness, $t = 1/8$ in.

Longitudinal Stress:

$$F = pA = 125[1.5(2) + \frac{1}{4}\pi(1.5)^2](12)^2$$

$$F = 85\,808.62 \text{ lbs}$$

$$P = F$$

$$\sigma_l [2(2 \times 12)(\frac{1}{8}) + \pi(1.5 \times 12)(\frac{1}{8})] = 85\,808.62$$

$$\sigma_l = 6\,566.02 \text{ psi}$$

$$\sigma_l = 6.57 \text{ ksi}$$

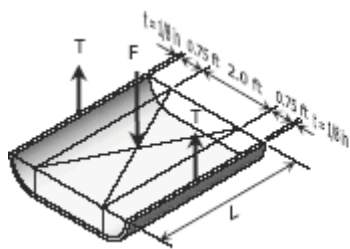

Circumferential Stress:

$$F = pA = 125[(2 \times 12)L + 2(0.75 \times 12)L]$$

$$F = 5250L \text{ lbs}$$

$$2T = F$$

$$2[\sigma_t \left(\frac{1}{8}\right) L] = 5250L$$

$$\sigma_t = 21\,000 \text{ psi}$$

$$\sigma_t = 21 \text{ ksi}$$

Problem 142

A pipe carrying steam at 3.5 MPa has an outside diameter of 450 mm and a wall thickness of 10 mm. A gasket is inserted between the flange at one end of the pipe and a flat plate used to cap the end. How many 40-mm-diameter bolts must be used to hold the cap on if the allowable stress in the bolts is 80 MPa, of which 55 MPa is the initial stress? What circumferential stress is developed in the pipe? Why is it necessary to tighten the bolt initially, and what will happen if the steam pressure should cause the stress in the bolts to be twice the value of the initial stress?

Solution 142

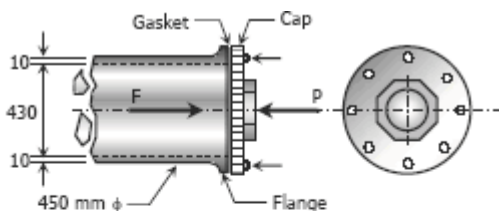

$$F = pA$$

$$= 3.5 \left[\frac{1}{4} \pi (430)^2 \right]$$

$$= 508\,270.42 \text{ N}$$

$$P = F$$

$$(\sigma_{\text{bolt}} A) n = 508\,270.42 \text{ N}$$

$$(80 - 55) \left[\frac{1}{4} \pi (40)^2 \right] n = 508\,270.42$$

$$n = 16.19 \text{ say } 17 \text{ bolts}$$

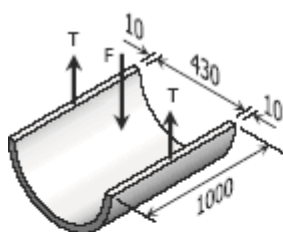

Circumferential stress (consider 1-m strip):

$$F = pA = 3.5[430(1000)]$$

$$F = 1\,505\,000 \text{ N}$$

$$2T = F$$

$$2[\sigma_t (1000)(10)] = 1\,505\,000$$

$$\sigma_t = 75.25 \text{ MPa}$$

Discussion:

It is necessary to tighten the bolts initially to press the gasket to the flange, to avoid leakage of steam. If the pressure will cause 110 MPa of stress to each bolt causing it to fail, leakage will occur. If this is sudden, the cap may blow.

Strain

Simple Strain

Also known as unit deformation, strain is the ratio of the change in length caused by the applied force, to the original length.

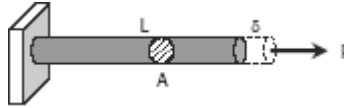

$$\epsilon = \frac{\delta}{L}$$

where δ is the deformation and L is the original length, thus ϵ is dimensionless.

Stress-Strain Diagram

Suppose that a metal specimen be placed in tension-compression testing machine. As the axial load is gradually increased in increments, the total elongation over the gage length is measured at each increment of the load and this is continued until failure of the specimen takes place. Knowing the original cross-sectional area and length of the specimen, the normal stress σ and the strain ϵ can be obtained. The graph of these quantities with the stress σ along the y-axis and the strain ϵ along the x-axis is called the stress-strain diagram. The stress-strain diagram differs in form for various materials. The diagram shown below is that for a medium carbon structural steel.

Metallic engineering materials are classified as either ductile or brittle materials. A ductile material is one having relatively large tensile strains up to the point of rupture like structural steel and aluminum, whereas brittle materials has a relatively small strain up to the point of rupture like cast iron and concrete. An arbitrary strain of 0.05 mm/mm is frequently taken as the dividing line between these two classes.

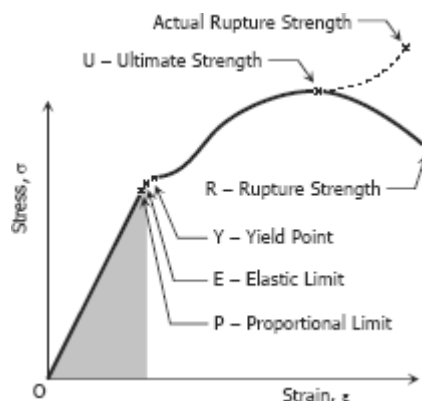

PROPORTIONAL LIMIT (HOOKE'S LAW)

From the origin O to the point called proportional limit, the stress-strain curve is a straight line. This linear relation between elongation and the axial force causing was first noticed by Sir Robert Hooke in 1678 and is called Hooke's Law that within the proportional limit, the stress is directly proportional to strain or



Robert Hooke

$$\sigma \propto \epsilon \text{ or } \sigma = k \epsilon$$

The constant of proportionality k is called the Modulus of Elasticity E or Young's Modulus and is equal to the slope of the stress-strain diagram from O to P. Then

$$\sigma = E \epsilon$$

ELASTIC LIMIT

The elastic limit is the limit beyond which the material will no longer go back to its original shape when the load is removed, or it is the maximum stress that may be developed such that there is no permanent or residual deformation when the load is entirely removed.

ELASTIC AND PLASTIC RANGES

The region in stress-strain diagram from O to P is called the elastic range. The region from P to R is called the plastic range.

YIELD POINT

Yield point is the point at which the material will have an appreciable elongation or yielding without any increase in load.

ULTIMATE STRENGTH

The maximum ordinate in the stress-strain diagram is the ultimate strength or tensile strength.

RAPTURE STRENGTH

Rapture strength is the strength of the material at rapture. This is also known as the breaking strength.

MODULUS OF RESILIENCE

Modulus of resilience is the work done on a unit volume of material as the force is gradually increased from O to P, in Nm/m^3 . This may be calculated as the area under the stress-strain curve from the origin O to up to the elastic limit E (the shaded area in the figure). The resilience of the material is its ability to absorb energy without creating a permanent distortion.

MODULUS OF TOUGHNESS

Modulus of toughness is the work done on a unit volume of material as the force is gradually increased from O to R, in Nm/m^3 . This may be calculated as the area under the entire stress-strain curve (from O to R). The toughness of a material is its ability to absorb energy without causing it to break.

WORKING STRESS, ALLOWABLE STRESS, AND FACTOR OF SAFETY

Working stress is defined as the actual stress of a material under a given loading. The maximum safe stress that a material can carry is termed as the allowable stress. The allowable stress should be limited to values not exceeding the proportional limit. However, since proportional limit is difficult to determine accurately, the allowable stress is taken as either the yield point or ultimate strength divided by a factor of safety. The ratio of this strength (ultimate or yield strength) to allowable strength is called the factor of safety.

AXIAL DEFORMATION

In the linear portion of the stress-strain diagram, the stress is proportional to strain and is given by

$$\sigma = E\varepsilon$$

since $\sigma = P / A$ and $\varepsilon = \delta / L$, then $P / A = E \delta / L$. Solving for δ ,

$$\delta = \frac{PL}{AE} = \frac{\sigma L}{E}$$

To use this formula, the load must be axial, the bar must have a uniform cross-sectional area, and the stress must not exceed the proportional limit. If however, the cross-sectional area is not uniform, the axial deformation can be determined by considering a differential length and applying integration.

If however, the cross-sectional area is not uniform, the axial deformation can be determined by considering a differential length and applying integration.

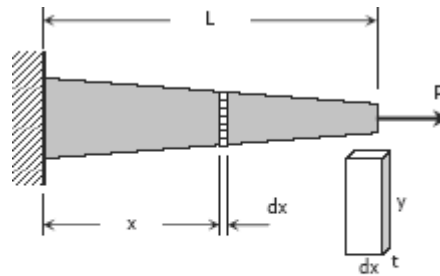

$$\delta = \frac{P}{E} \int_0^L \frac{dx}{A}$$

where $A = ty$ and y and t , if variable, must be expressed in terms of x .

For a rod of unit mass ρ suspended vertically from one end, the total elongation due to its own weight is

$$\delta = \frac{\rho g L^2}{2E} = \frac{MgL}{2AE}$$

where ρ is in kg/m^3 , L is the length of the rod in mm, M is the total mass of the rod in kg, A is the cross-sectional area of the rod in mm^2 , and $g = 9.81 \text{ m/s}^2$.

STIFFNESS, k

Stiffness is the ratio of the steady force acting on an elastic body to the resulting displacement. It has the unit of N/mm.

$$k = P / \delta$$

SOLVED PROBLEMS IN AXIAL DEFORMATION

Problem 206

A steel rod having a cross-sectional area of 300 mm^2 and a length of 150 m is suspended vertically from one end. It supports a tensile load of 20 kN at the lower end. If the unit mass of steel is 7850 kg/m^3 and $E = 200 \times 10^3 \text{ MN/m}^2$, find the total elongation of the rod.

Solution 206

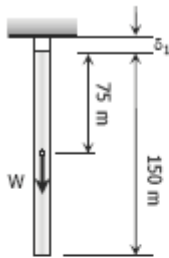

Let δ = total elongation

δ_1 = elongation due to its own weight

δ_2 = elongation due to applied load

$$\delta = \delta_1 + \delta_2$$

$$\delta_1 = \frac{PL}{AE}$$

$$\text{Where: } P = W = 7850(1/1000)^3(9.81)[300(150)(1000)]$$

$$P = 3465.3825 \text{ N}$$

$$L = 75(1000) = 75\,000 \text{ mm}$$

$$A = 300 \text{ mm}^2$$

$$E = 200\,000 \text{ MPa}$$

$$\delta_1 = \frac{3465.3825(75000)}{300(200\,000)} = 4.33 \text{ mm}$$

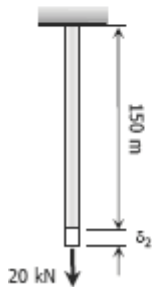

$$\delta_2 = \frac{PL}{AE}$$

$$\text{Where: } P = 20 \text{ kN} = 20\,000 \text{ N}$$

$$L = 150 \text{ m} = 150\,000 \text{ mm}$$

$$A = 300 \text{ mm}^2$$

$$E = 200\,000 \text{ MPa}$$

$$\delta_2 = \frac{20000(150000)}{300(200000)} = 50 \text{ mm}$$

Total elongation:

$$\delta = 4.33 + 50 = 54.33 \text{ mm}$$

Problem 207

A steel wire 30 ft long, hanging vertically, supports a load of 500 lb . Neglecting the weight of the wire, determine the required diameter if the stress is not to exceed 20 ksi and the total elongation is not to exceed 0.20 in . Assume $E = 29 \times 10^6 \text{ psi}$.

Solution 207

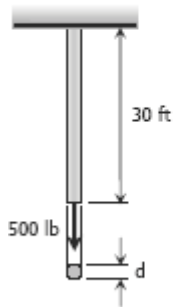

Based on maximum allowable stress:

$$\sigma = \frac{P}{A}$$

$$20\,000 = \frac{500}{\frac{1}{4}\pi d^2}$$

$$d = 0.0318 \text{ in}$$

Based on maximum allowable deformation:

$$\delta = \frac{PL}{AE}$$

$$0.20 = \frac{500(30 \times 12)}{\frac{1}{4}\pi d^2 (29 \times 10^6)}$$

$$d = 0.0395 \text{ in}$$

Use the bigger diameter, $d = 0.0395 \text{ in}$

Problem 208

A steel tire, 10 mm thick, 80 mm wide, and 1500.0 mm inside diameter, is heated and shrunk onto a steel wheel 1500.5 mm in diameter. If the coefficient of static friction is 0.30, what torque is required to twist the tire relative to the wheel? Neglect the deformation of the wheel. Use $E = 200 \text{ GPa}$.

Solution 208

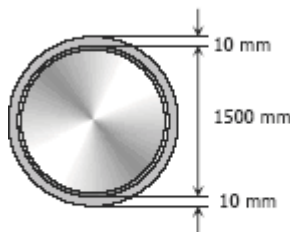

$$\delta = \frac{PL}{AE}$$

Where: $\delta = \pi(1500.5 - 1500) = 0.5\pi \text{ mm}$
 $P = T$
 $L = 1500\pi \text{ mm}$
 $A = 10(80) = 800 \text{ mm}^2$
 $E = 200\,000 \text{ MPa}$

$$0.5\pi = \frac{T(1500\pi)}{800(200\,000)}$$

$$T = 53\,333.33 \text{ N}$$

$$F = 2T$$

$$p(1500)(80) = 2(53\,333.33)$$

$$p = 0.8889 \text{ MPa} \rightarrow \text{internal pressure}$$

Total normal force, N :

$$N = p \times \text{contact area between tire and wheel}$$

$$N = 0.8889 \times \pi(1500.5)(80)$$

$$N = 335\,214.92 \text{ N}$$

Friction resistance, f :

$$f = \mu N = 0.30(335\,214.92)$$

$$f = 100\,564.48 \text{ N} = 100.56 \text{ kN}$$

$$\text{Torque} = f \times \frac{1}{2} (\text{diameter of wheel})$$

$$\text{Torque} = 100.56 \times 0.75025$$

$$\text{Torque} = 75.44 \text{ kN}\cdot\text{m}$$

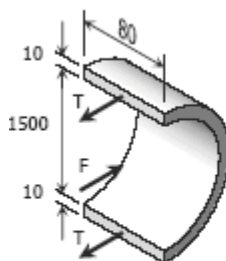

Problem 209

An aluminum bar having a cross-sectional area of 0.5 in^2 carries the axial loads applied at the positions shown in Fig. P-209. Compute the total change in length of the bar if $E = 10 \times 10^6 \text{ psi}$. Assume the bar is suitably braced to prevent lateral buckling.

Figure P-209 and P-210

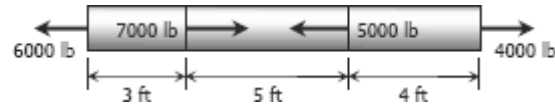

Solution 209

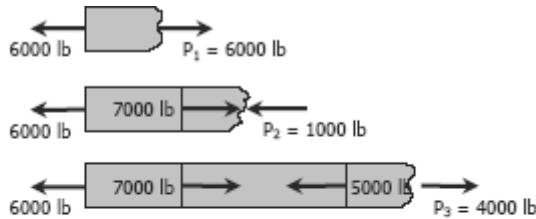

$$P_1 = 6000 \text{ lb tension}$$

$$P_2 = 1000 \text{ lb compression}$$

$$P_3 = 4000 \text{ lb tension}$$

$$\delta = \frac{PL}{AE}$$

$$\delta = \delta_1 - \delta_2 + \delta_3$$

$$\delta = \frac{6000(3 \times 12)}{0.5(10 \times 10^6)} - \frac{1000(5 \times 12)}{0.5(10 \times 10^6)} + \frac{4000(4 \times 12)}{0.5(10 \times 10^6)}$$

$$\delta = 0.0696 \text{ in (lengthening)}$$

Problem 210

Solve Prob. 209 if the points of application of the 6000-lb and the 4000-lb forces are interchanged.

Solution 210

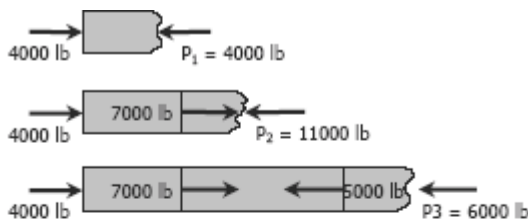

$$P_1 = 4000 \text{ lb compression}$$

$$P_2 = 11000 \text{ lb compression}$$

$$P_3 = 6000 \text{ lb compression}$$

$$\delta = \frac{PL}{AE}$$

$$\delta = -\delta_1 - \delta_2 - \delta_3$$

$$\delta = -\frac{4000(3 \times 12)}{0.5(10 \times 10^6)} - \frac{11000(5 \times 12)}{0.5(10 \times 10^6)} - \frac{6000(4 \times 12)}{0.5(10 \times 10^6)}$$

$$\delta = -0.19248 \text{ in} = 0.19248 \text{ in (shortening)}$$

Problem 211

A bronze bar is fastened between a steel bar and an aluminum bar as shown in Fig. P-211. Axial loads are applied at the positions indicated. Find the largest value of P that will not exceed an overall deformation of 3.0 mm, or the following stresses: 140 MPa in the steel, 120 MPa in the bronze, and 80 MPa in the aluminum. Assume that the assembly is suitably braced to prevent buckling. Use $E_{st} = 200$ GPa, $E_{al} = 70$ GPa, and $E_{br} = 83$ GPa.

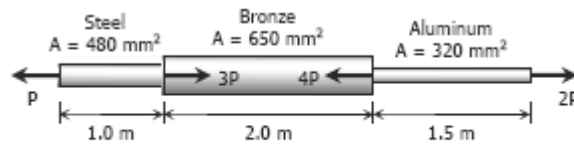

Figure P -211

Solution 211

Based on allowable stresses:

Steel:

$$P_{st} = \sigma_{st} A_{st}$$

$$P = 140(480) = 67\,200 \text{ N}$$

$$P = 67.2 \text{ kN}$$

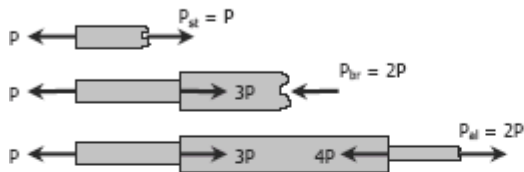

Bronze:

$$P_{br} = \sigma_{br} A_{br}$$

$$2P = 120(650) = 78\,000$$

$$P = 39\,000 \text{ N} = 39 \text{ kN}$$

Aluminum:

$$P_{al} = \sigma_{al} A_{al}$$

$$2P = 80(320) = 25\,600 \text{ N}$$

$$P = 12\,800 \text{ N} = 12.8 \text{ kN}$$

Based on allowable deformation:

(steel and aluminum lengthens, bronze shortens)

$$\delta = \delta_{st} - \delta_{br} + \delta_{al}$$

$$3 = \frac{P(1000)}{480(200\,000)} - \frac{2P(2000)}{650(70\,000)} + \frac{2P(1500)}{320(83\,000)}$$

$$3 = \left(\frac{1}{96\,000} - \frac{1}{113.75} + \frac{3}{26560} \right) P$$

$$P = 84\,610.99 \text{ N} = 84.61 \text{ kN}$$

Use the smallest value of P , $P = 12.8 \text{ kN}$

Problem 212

The rigid bar ABC shown in Fig. P-212 is hinged at A and supported by a steel rod at B. Determine the largest load P that can be applied at C if the stress in the steel rod is limited to 30 ksi and the vertical movement of end C must not exceed 0.10 in.

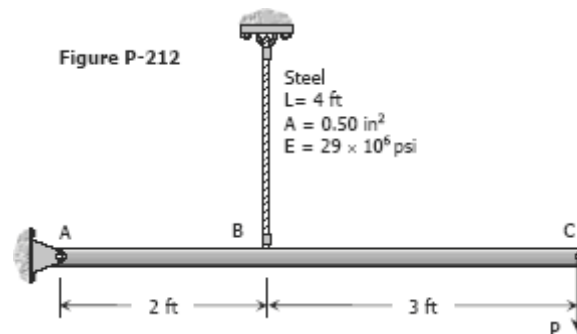

Solution 212

Free body and deformation diagrams:

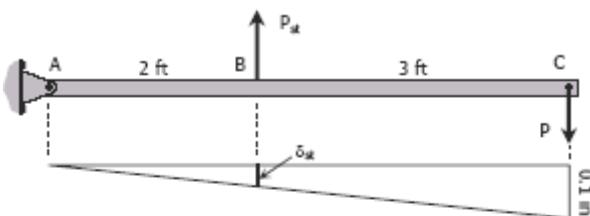

Based on maximum stress of steel rod:

$$\begin{aligned}\sum M_A &= 0 \\ 5P &= 2P_{st} \\ P &= 0.4P_{st} \\ P &= 0.4\sigma_{st}A_{st} \\ P &= 0.4[30(0.50)] \\ P &= 6 \text{ kips}\end{aligned}$$

Based on movement at C:

$$\begin{aligned}\frac{\delta_{st}}{2} &= \frac{0.1}{5} \\ \delta_{st} &= 0.04 \text{ in} \\ \frac{P_{st}L}{AE} &= 0.04 \\ \frac{P_{st}(4 \times 12)}{0.50(29 \times 10^6)} &= 0.04 \\ P_{st} &= 12\,083.33 \text{ lb} \\ \sum M_A &= 0 \\ 5P &= 2P_{st} \\ P &= 0.4P_{st} \\ P &= 0.4(12\,083.33) \\ P &= 4833.33 \text{ lb} = 4.83 \text{ kips}\end{aligned}$$

Use the smaller value, $P = 4.83$ kips

Problem 213

The rigid bar AB, attached to two vertical rods as shown in Fig. P-213, is horizontal before the load P is applied. Determine the vertical movement of P if its magnitude is 50 kN.

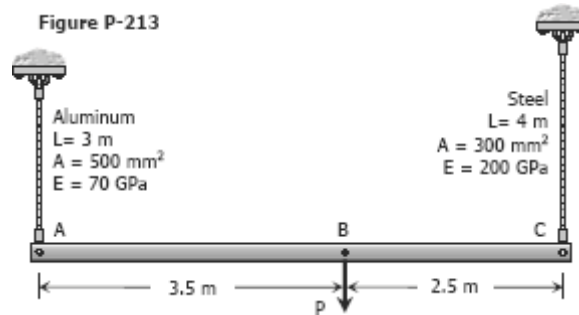

Solution 213

Free body diagram:

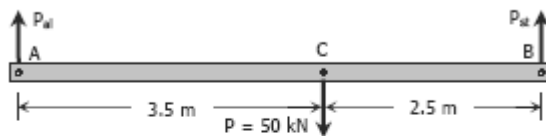

For aluminum:

$$[\Sigma M_B = 0] \quad 6P_{al} = 2.5(50)$$

$$P_{al} = 20.83 \text{ kN}$$

$$\left[\delta = \frac{PL}{AE} \right]_{al} \quad \delta_{al} = \frac{20.83(3)1000^2}{500(70000)}$$

$$\delta_{al} = 1.78 \text{ mm}$$

For steel:

$$[\Sigma M_A = 0] \quad 6P_{st} = 3.5(50)$$

$$P_{st} = 29.17 \text{ kN}$$

$$\left[\delta = \frac{PL}{AE} \right]_{st} \quad \delta_{st} = \frac{29.17(4)1000^2}{300(200000)}$$

$$\delta_{st} = 1.94 \text{ mm}$$

Movement diagram:

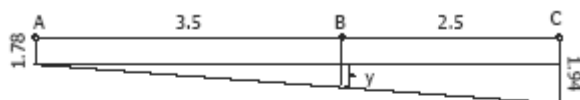

$$\frac{y}{3.5} = \frac{1.94 - 1.78}{6}$$

$$y = 0.09 \text{ mm}$$

$$\delta_B = \text{vertical movement of } P$$

$$\delta_B = 1.78 + y = 1.78 + 0.09$$

$$\delta_B = 1.87 \text{ mm}$$

Problem 214

The rigid bars AB and CD shown in Fig. P-214 are supported by pins at A and C and the two rods. Determine the maximum force P that can be applied as shown if its vertical movement is limited to 5 mm. Neglect the weights of all members.

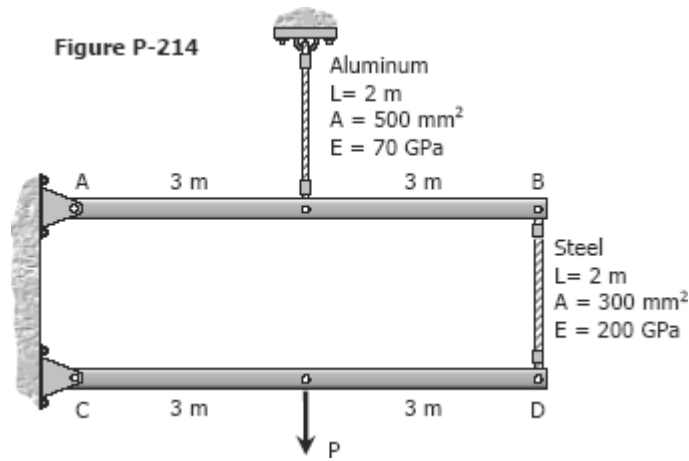

Solution 214

$$[\Sigma M_A = 0] \quad 3P_{al} = 6P_{st}$$

$$P_{al} = 2P_{st}$$

By ratio and proportion:

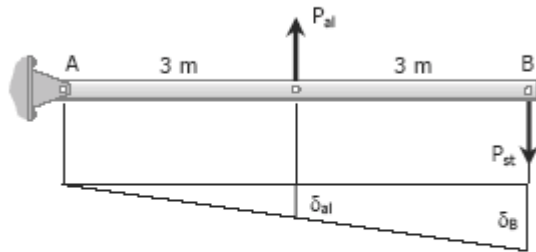

FBD and movement diagram of bar AB

$$\frac{\delta_B}{6} = \frac{\delta_{al}}{3}$$

$$\delta_B = 2\delta_{al} = 2 \left[\frac{PL}{AE} \right]_{al}$$

$$\delta_B = 2 \left[\frac{P_{al}(2000)}{500(70000)} \right]$$

$$\delta_B = \frac{1}{8750} P_{al} = \frac{1}{8750} (2P_{st})$$

$$\delta_B = \frac{1}{4375} P_{st} \rightarrow \text{movement of B}$$

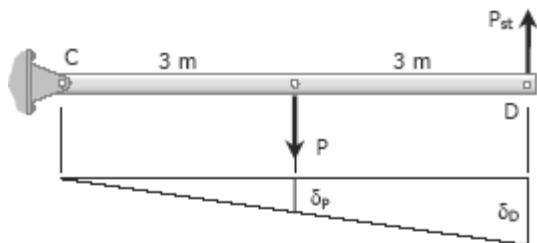

FBD and movement diagram of bar CD

Movement of D:

$$\delta_D = \delta_{st} + \delta_B = \left[\frac{PL}{AE} \right]_{st} + \frac{1}{4375} P_{st}$$

$$\delta_D = \frac{P_{st}(2000)}{300(200000)} + \frac{1}{4375} P_{st}$$

$$\delta_D = \frac{11}{42000} P_{st}$$

$$[\Sigma M_C = 0] \quad 6P_{st} = 3P$$

$$P_{st} = \frac{1}{2} P$$

By ratio and proportion:

$$\frac{\delta_P}{3} = \frac{\delta_D}{6}$$

$$\delta_P = \frac{1}{2} \delta_D = \frac{1}{2} \left(\frac{11}{42000} P_{st} \right)$$

$$\delta_P = \frac{11}{84000} P_{st}$$

$$5 = \frac{11}{84000} \left(\frac{1}{2} P \right)$$

$$P = 76\,363.64 \text{ N} = 76.4 \text{ kN}$$

Problem 215

A uniform concrete slab of total weight W is to be attached, as shown in Fig. P-215, to two rods whose lower ends are on the same level. Determine the ratio of the areas of the rods so that the slab will remain level.

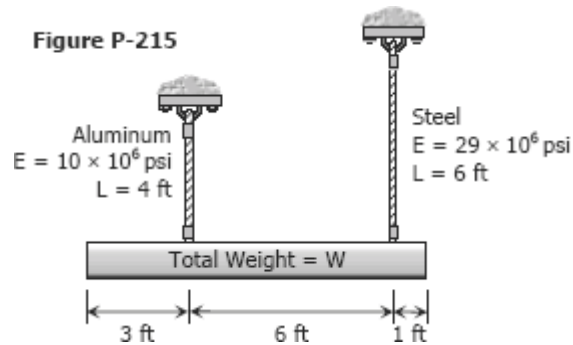

Solution 215

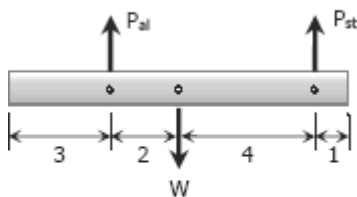

$$[\sum M_{al} = 0] \quad 6P_{st} = 2W$$

$$P_{st} = \frac{1}{3}W$$

$$[\sum M_{st} = 0] \quad 6P_{al} = 4W$$

$$P_{al} = \frac{2}{3}W$$

$$\delta_{st} = \delta_{al}$$

$$\left[\frac{PL}{AE} \right]_{st} = \left[\frac{PL}{AE} \right]_{al}$$

$$\frac{\frac{1}{3}W(6 \times 12)}{A_{st}(29 \times 10^6)} = \frac{\frac{2}{3}W(4 \times 12)}{A_{al}(10 \times 10^6)}$$

$$\frac{A_{al}}{A_{st}} = \frac{\frac{2}{3}W(4 \times 12)(29 \times 10^6)}{\frac{1}{3}W(6 \times 12)(10 \times 10^6)}$$

$$A_{al}/A_{st} = 3.867$$

Problem 216

As shown in Fig. P-216, two aluminum rods AB and BC, hinged to rigid supports, are pinned together at B to carry a vertical load $P = 6000$ lb. If each rod has a crosssectional area of 0.60 in² and $E = 10 \times 10^6$ psi, compute the elongation of each rod and the horizontal and vertical displacements of point B. Assume $\alpha = 30^\circ$ and $\theta = 30^\circ$.

Solution 216

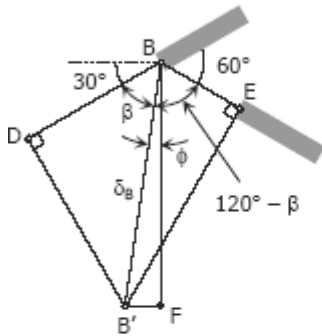
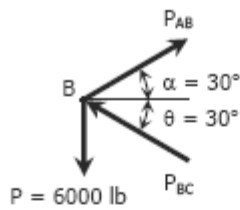

Movement of B

$$[\Sigma F_H = 0] \quad P_{AB} \cos 30^\circ = P_{BC} \cos 30^\circ$$

$$P_{AB} = P_{BC}$$

$$[\Sigma F_V = 0] \quad P_{AB} \sin 30^\circ + P_{BC} \sin 30^\circ = 6000$$

$$P_{AB} (0.5) + P_{AB} (0.5) = 6000$$

$$P_{AB} = 6000 \text{ lb tension}$$

$$P_{BC} = 6000 \text{ lb compression}$$

$$\delta = \frac{PL}{AE}$$

$$\delta_{AB} = \frac{6000(10 \times 12)}{0.6(10 \times 10^6)} = 0.12 \text{ in. lengthening}$$

$$\delta_{BC} = \frac{6000(6 \times 12)}{0.6(10 \times 10^6)} = 0.072 \text{ in. shortening}$$

$$DB = \delta_{AB} = 0.12 \text{ in}$$

$$BE = \delta_{BE} = 0.072 \text{ in}$$

$$\delta_B = BB' = \text{displacement of } B$$

B' = final position of B after elongation

Triangle BDB' :

$$\cos \beta = \frac{0.12}{\delta_B}$$

$$\delta_B = \frac{0.12}{\cos \beta}$$

Triangle BEB' :

$$\cos (120^\circ - \beta) = \frac{0.072}{\delta_B}$$

$$\delta_B = \frac{0.072}{\cos (120^\circ - \beta)}$$

$$\delta_B = \delta_B$$

$$\frac{0.12}{\cos \beta} = \frac{0.072}{\cos (120^\circ - \beta)}$$

$$\frac{\cos 120^\circ \cos \beta + \sin 120^\circ \sin \beta}{\cos \beta} = 0.6$$

$$-0.5 + \sin 120^\circ \tan \beta = 0.6$$

$$\tan \beta = 1.1 / \sin 120^\circ; \beta = 51.79^\circ$$

$$\phi = 90 - (30^\circ + \beta) = 90^\circ - (30^\circ + 51.79^\circ)$$

$$\phi = 8.21^\circ$$

$$\delta_B = \frac{0.12}{\cos 51.79^\circ}$$

$$\delta_B = 0.194 \text{ in}$$

Triangle BFB' :

$$\delta_h = B'F = \delta_B \sin \phi = 0.194 \sin 8.21^\circ$$

$$\delta_h = 0.0277 \text{ in}$$

$$\delta_h = \mathbf{0.0023 \text{ ft}} \rightarrow \text{horizontal displacement of B}$$

$$\delta_v = BF = \delta_B \cos \phi = 0.194 \cos 8.21^\circ$$

$$\delta_v = 0.192 \text{ in}$$

$$\delta_v = \mathbf{0.016 \text{ ft}} \rightarrow \text{vertical displacement of B}$$

Problem 217

Solve Prob. 216 if rod AB is of steel, with $E = 29 \times 10^6$ psi. Assume $\alpha = 45^\circ$ and $\theta = 30^\circ$; all other data remain unchanged.

Solution 217

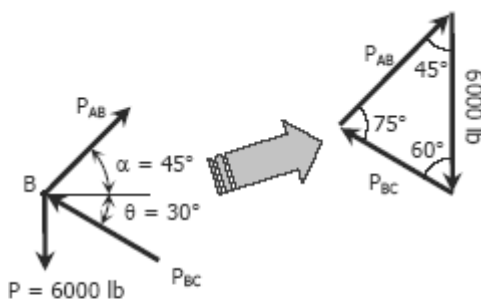

By Sine Law

$$\frac{P_{AB}}{\sin 60^\circ} = \frac{6000}{\sin 75^\circ}$$

$$P_{AB} = 5379.45 \text{ lb (Tension)}$$

$$\frac{P_{BC}}{\sin 45^\circ} = \frac{6000}{\sin 75^\circ}$$

$$P_{BC} = 4392.30 \text{ lb (Compression)}$$

$$\delta = \frac{PL}{AE}$$

$$\delta_{AB} = \frac{5379.45(10 \times 12)}{0.6(29 \times 10^6)} = \mathbf{0.0371 \text{ in. (lengthening)}}$$

$$\delta_{BC} = \frac{4392.30(6 \times 12)}{0.6(10 \times 10^6)} = 0.0527 \text{ in. (shortening)}$$

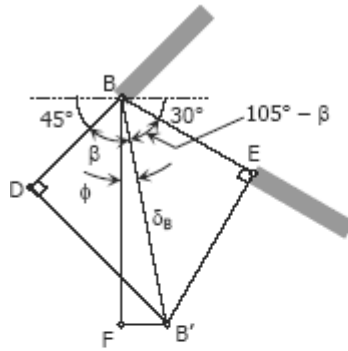

Movement of B

$$DB = \delta_{AB} = 0.0371 \text{ in}$$

$$BE = \delta_{BE} = 0.0527 \text{ in}$$

$\delta_B = BB'$ = displacement of B

B' = final position of B after deformation

Triangle BDB' :

$$\cos \beta = \frac{0.0371}{\delta_B}$$

$$\delta_B = \frac{0.0371}{\cos \beta}$$

Triangle BEB' :

$$\cos (105^\circ - \beta) = \frac{0.0527}{\delta_B}$$

$$\delta_B = \frac{0.0527}{\cos (105^\circ - \beta)}$$

$$\delta_B = \delta_B$$

$$\frac{0.0371}{\cos \beta} = \frac{0.0527}{\cos (105^\circ - \beta)}$$

$$\frac{\cos 105^\circ \cos \beta + \sin 105^\circ \sin \beta}{\cos \beta} = 1.4205$$

$$-0.2588 + 0.9659 \tan \beta = 1.4205$$

$$\tan \beta = \frac{1.4205 + 0.2588}{0.9659}$$

$$\tan \beta = 1.7386$$

$$\beta = 60.1^\circ$$

$$\delta_B = \frac{0.0371}{\cos 60.1^\circ}$$

$$\delta_B = 0.0744 \text{ in}$$

$$\begin{aligned} \phi &= (45^\circ + \beta) - 90^\circ \\ &= (45^\circ + 60.1^\circ) - 90^\circ \\ &= 15.1^\circ \end{aligned}$$

Triangle BFB' :

$$\delta_h = FB' = \delta_B \sin \phi = 0.0744 \sin 15.1^\circ$$

$$\delta_h = 0.0194 \text{ in}$$

$$\delta_h = 0.00162 \text{ ft} \rightarrow \text{horizontal displacement of B}$$

$$\delta_v = BF = \delta_B \cos \phi = 0.0744 \cos 15.1^\circ$$

$$\delta_v = 0.07183 \text{ in}$$

$$\delta_v = 0.00598 \text{ ft} \rightarrow \text{vertical displacement of B}$$

Problem 218

A uniform slender rod of length L and cross sectional area A is rotating in a horizontal plane about a vertical axis through one end. If the unit mass of the rod is ρ , and it is rotating at a constant angular velocity of ω rad/sec, show that the total elongation of the rod is $\rho\omega^2 L^3/3E$.

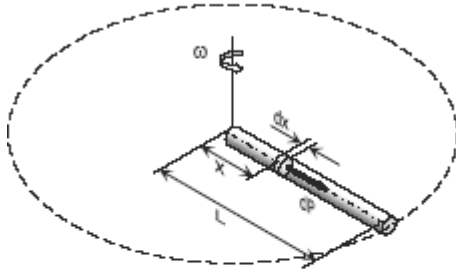
Solution 218

$$\delta = \frac{PL}{AE}$$

from the figure:

$$d\delta = \frac{dP x}{AE}$$

Where:

dP = centrifugal force of differential mass

$dP = dM \omega^2 x = (\rho A dx) \omega^2 x$

$dP = \rho A \omega^2 x dx$

$$d\delta = \frac{(\rho A \omega^2 x dx) x}{AE}$$

$$\delta = \frac{\rho\omega^2}{E} \int_0^L x^2 dx = \frac{\rho\omega^2}{E} \left[\frac{x^3}{3} \right]_0^L$$

$$\delta = \frac{\rho\omega^2}{3E} [L^3 - 0^3]$$

$$\delta = \rho\omega^2 L^3/3E \quad \text{ok!}$$

Problem 219

A round bar of length L , which tapers uniformly from a diameter D at one end to a smaller diameter d at the other, is suspended vertically from the large end. If w is the weight per unit volume, find the elongation of the rod caused by its own weight. Use this result to determine the elongation of a cone suspended from its base.

Solution 219

$$\delta = \frac{PL}{AE}$$

For the differential strip shown:

$$\delta = d\delta$$

P = weight carried by the strip
= weight of segment y

$$L = dy$$

A = area of the strip

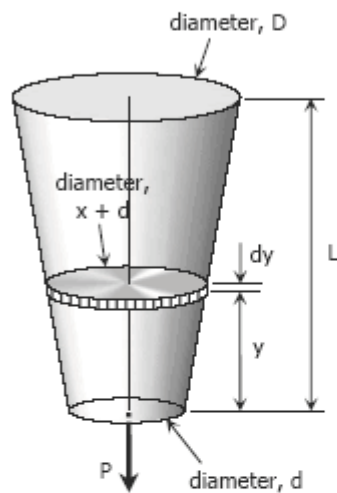

For weight of segment y (Frustum of a cone):

$$P = wV_y$$

From section along the axis

$$\frac{x}{y} = \frac{D-d}{L}$$

$$x = \frac{D-d}{L}y$$

Volume for frustum of cone

$$V = \frac{1}{3}\pi h (R^2 + r^2 + Rr)$$

$$V_y = \frac{1}{3}\pi h \left[\frac{1}{4}(x+d)^2 + \frac{1}{4}d^2 + \frac{1}{2}(x+d)\left(\frac{1}{2}d\right) \right]$$

$$V_y = \frac{1}{12}\pi y [(x+d)^2 + d^2 + (x+d)d]$$

$$P = \frac{1}{12}\pi w [(x+d)^2 + d^2 + (x+d)d] y$$

$$P = \frac{1}{12}\pi w [x^2 + 2xd + d^2 + d^2 + xd + d^2] y$$

$$P = \frac{1}{12}\pi w [x^2 + 3xd + 3d^2] y$$

$$P = \frac{\pi w}{12} \left[\frac{(D-d)^2}{L^2} y^2 + \frac{3d(D-d)}{L} y + 3d^2 \right] y$$

Area of the strip:

$$A = \frac{1}{4}\pi(x+d)^2 = \frac{\pi}{4} \left(\frac{D-d}{L}y + d \right)^2$$

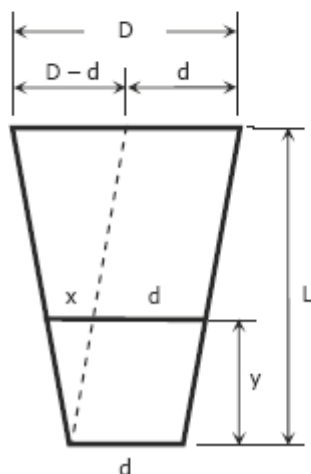

Section along the axis of the bar

Thus,

$$\delta = \frac{PL}{AE}$$

$$d\delta = \frac{\frac{\pi w}{12} \left[\frac{(D-d)^2}{L^2} y^2 + \frac{3d(D-d)}{L} y + 3d^2 \right] y \, dy}{\frac{\pi}{4} \left(\frac{D-d}{L} y + d \right)^2 E}$$

$$d\delta = \frac{4w}{12E} \left[\frac{\frac{(D-d)^2}{L^2} y^2 + \frac{3d(D-d)}{L} y + 3d^2}{\frac{(D-d)^2}{L^2} y^2 + \frac{2d(D-d)}{L} y + d^2} \right] y \, dy$$

$$d\delta = \frac{w}{3E} \left[\frac{\frac{(D-d)^2 y^2 + 3Ld(D-d)y + 3L^2 d^2}{L^2}}{\frac{(D-d)^2 y^2 + 2Ld(D-d)y + L^2 d^2}{L^2}} \right] y \, dy$$

$$d\delta = \frac{w}{3E} \left[\frac{(D-d)^2 y^2 + 3Ld(D-d)y + 3L^2 d^2}{(D-d)^2 y^2 + 2Ld(D-d)y + L^2 d^2} \right] y \, dy$$

Let: $a = D - d$; $b = Ld$

$$d\delta = \frac{w}{3E} \left[\frac{a^2 y^2 + 3aby + 3b^2}{a^2 y^2 + 2aby + b^2} \right] y \, dy$$

$$d\delta = \frac{w}{3E} \left[\frac{a^2 y^2 + 3aby + 3b^2}{(ay)^2 + 2(ay)b + b^2} \times \frac{a}{a} \right] y \, dy$$

$$d\delta = \frac{w}{3aE} \left[\frac{a^3 y^3 + 3(a^2 y^2)b + 3(ay)b^2}{(ay + b)^2} \right] dy$$

$$d\delta = \frac{w}{3aE} \left\{ \frac{[(ay)^3 + 3(ay)^2 b + 3(ay)b^2 + b^3] - b^3}{(ay + b)^2} \right\} dy$$

The quantity $(ay)^3 + 3(ay)^2 b + 3(ay)b^2 + b^3$ is the expansion of $(ay + b)^3$

$$d\delta = \frac{w}{3aE} \left[\frac{(ay + b)^3 - b^3}{(ay + b)^2} \right] dy$$

$$d\delta = \frac{w}{3aE} \left[\frac{(ay + b)^3}{(ay + b)^2} - \frac{b^3}{(ay + b)^2} \right] dy$$

$$\delta = \frac{w}{3aE} [(ay+b) - b^3(ay+b)^{-2}] dy$$

$$\delta = \frac{w}{3aE} \int_0^L [(ay+b) - b^3(ay+b)^{-2}] dy$$

$$\delta = \frac{w}{3aE} \left[\frac{(ay+b)^2}{2a} - \frac{b^3(ay+b)^{-1}}{-a} \right]_0^L$$

$$\delta = \frac{w}{3a^2E} \left[\frac{(ay+b)^2}{2} + \frac{b^3}{ay+b} \right]_0^L$$

$$\delta = \frac{w}{3a^2E} \left\{ \left[\frac{1}{2}(aL+b)^2 + \frac{b^3}{aL+b} \right] - \left[\frac{1}{2}b^2 + \frac{b^3}{b} \right] \right\}$$

$$\delta = \frac{w}{3a^2E} \left\{ \frac{1}{2}(aL+b)^2 + \frac{b^3}{aL+b} - \frac{3}{2}b^2 \right\}$$

$$\delta = \frac{w}{3a^2E} \left[\frac{(aL+b)^3 + 2b^3 - 3b^2(aL+b)}{2(aL+b)} \right]$$

$$\delta = \frac{w}{6a^2E} \left[\frac{(aL)^3 + 3(aL)^2b + 3(aL)b^2 + b^3 + 2b^3 - 3ab^2L - 3b^3}{aL+b} \right]$$

$$\delta = \frac{w}{6a^2E} \left[\frac{a^3L^3 + 3a^2bL^2}{aL+b} \right]; \text{Note: } a = D - d \text{ \& } b = Ld$$

$$\delta = \frac{w}{6(D-d)^2E} \left[\frac{(D-d)^3L^3 + 3(D-d)^2(Ld)L^2}{(D-d)L + (Ld)} \right]$$

$$\delta = \frac{w}{6(D-d)^2E} \left\{ \frac{(D-d)L^3[(D-d)^2 + 3d(D-d)]}{LD - Ld + Ld} \right\}$$

$$\delta = \frac{wL^3}{6(D-d)E} \left[\frac{(D-d)^2 + 3d(D-d)}{LD} \right]$$

$$\delta = \frac{wL^3}{6(D-d)E} \left[\frac{D^2 - 2Dd + d^2 + 3Dd - 3d^2}{LD} \right]$$

$$\delta = \frac{wL^3}{6(D-d)E} \left[\frac{D^2 + Dd - 2d^2}{LD} \right]$$

$$\delta = \frac{wL^3}{6(D-d)E} \left[\frac{D(D+d) - 2d^2}{LD} \right]$$

$$\delta = \frac{wL^3}{6(D-d)E} \left[\frac{D(D+d)}{LD} \right] - \frac{wL^3}{6(D-d)E} \left[\frac{2d^2}{LD} \right]$$

$$\delta = \frac{wL^2(D+d)}{6E(D-d)} - \frac{wL^2d^2}{3ED(D-d)}$$

For a cone:

$$D = D \text{ and } d = 0$$

$$\delta = \frac{wL^2(D+0)}{6E(D-0)} - \frac{wL^2(0)^2}{3ED(D-0)}$$

$$\delta = \frac{wL^2}{6E}$$

SOLVED PROBLEMS IN STRAIN AND AXIAL DEFORMATION

Problem 203

The following data were recorded during the tensile test of a 14-mm-diameter mild steel rod. The gage length was 50 mm.

Load (N)	Elongation (mm)	Load (N)	Elongation (mm)
0	0	46200	1.25
6310	0.010	52400	2.50
12600	0.020	58500	4.50
18800	0.030	68000	7.50
25100	0.040	59000	12.50
31300	0.050	67800	15.50
37900	0.060	65000	20.00
40100	0.163	61500	Fracture
41600	0.433		

Plot the stress-strain diagram and determine the following mechanical properties: (a) proportional limits; (b) modulus of elasticity; (c) yield point; (d) ultimate strength; and (e) rupture strength.

Solution 203

Area, $A = \frac{1}{4} \pi(14)^2 = 49\pi \text{ mm}^2$; Length, $L = 50 \text{ mm}$

Strain = Elongation/Length; Stress = Load/Area

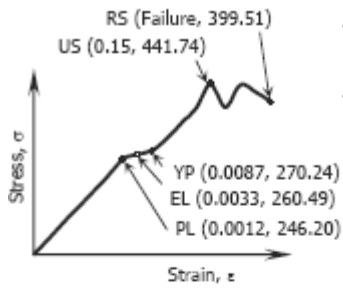

Stress-Strain Diagram
(not drawn to scale)

PL = Proportional Limit
EL = Elastic Limit
YP = Yield Point
US = Ultimate Strength
RS = Rupture Strength

Load (N)	Elongation (mm)	Strain (mm/mm)	Stress (MPa)
0	0	0	0
6310	0.010	0.0002	40.99
12600	0.020	0.0004	81.85
18800	0.030	0.0006	122.13
25100	0.040	0.0008	163.05
31300	0.050	0.001	203.33
37900	0.060	0.0012	246.20
40100	0.163	0.0033	260.49
41600	0.433	0.0087	270.24
46200	1.250	0.025	300.12
52400	2.500	0.05	340.40
58500	4.500	0.09	380.02
68000	7.500	0.15	441.74
59000	12.500	0.25	383.27
67800	15.500	0.31	440.44
65000	20.000	0.4	422.25
61500	Failure		399.51

From stress-strain diagram:

- Proportional Limit = 246.20 MPa
- Modulus of Elasticity
 $E = \text{slope of stress-strain diagram within proportional limit}$
 $E = \frac{246.20}{0.0012} = 205\,166.67 \text{ MPa}$
 $E = 205.2 \text{ GPa}$
- Yield Point = 270.24 MPa
- Ultimate Strength = 441.74 MPa
- Rupture Strength = 399.51 MPa

Problem 204

The following data were obtained during a tension test of an aluminum alloy. The initial diameter of the test specimen was 0.505 in. and the gage length was 2.0 in.

Load (lb)	Elongation (in.)	Load (lb)	Elongation (in.)
0	0	14 000	0.020
2 310	0.00220	14 400	0.025
4 640	0.00440	14 500	0.060
6 950	0.00660	14 600	0.080
9 290	0.00880	14 800	0.100
11 600	0.0110	14 600	0.120
12 600	0.0150	13 600	Fracture

Plot the stress-strain diagram and determine the following mechanical properties: (a) proportional limit; (b) modulus of elasticity; (c) yield point; (d) yield strength at 0.2% offset; (e) ultimate strength; and (f) rupture strength.

Solution 204

Area = $\frac{1}{4} \pi (0.505)^2 = 0.0638\pi \text{ in}^2$; Length, $L = 2.0 \text{ in}$.

Strain = Elongation/Length; Stress = Load/Area

Load (lb)	Elongation (in)	Strain (in/in)	Stress (psi)
0	0	0	0
2310	0.0022	0.0011	11532.92
4640	0.0044	0.0022	23165.70
6950	0.0066	0.0033	34698.62
9290	0.0088	0.0044	46381.32
11600	0.011	0.0055	57914.24
12600	0.015	0.0075	62906.85
14000	0.02	0.01	69896.49
14400	0.025	0.0125	71893.54
14500	0.06	0.03	72392.80
14600	0.08	0.04	72892.06
14800	0.1	0.05	73890.58
14600	0.12	0.06	72892.06
13600	Fracture		67899.45

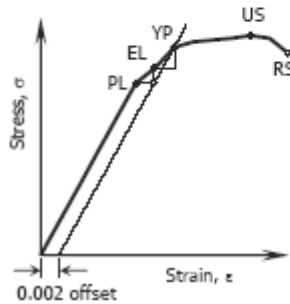

- PL (0.0055, 57914.24)
- EL (0.0075, 62906.85)
- YP (0.01, 69896.49)
- US (0.05, 73890.58)
- RS (Failure, 67899.45)

From stress-strain diagram:

(a) Proportional Limit = 57,914.24 psi

(b) Modulus of Elasticity:

$$E = \frac{57914.24}{0.0055} = 10,529,861.82 \text{ psi}$$

$$E = 10,529.86 \text{ ksi}$$

(c) Yield Point = 69,896.49 psi

(d) Yield Strength at 0.2% Offset:

Strain of Elastic Limit

$$= \epsilon \text{ at PL} + 0.002$$

$$= 0.0055 + 0.002$$

$$= 0.0075 \text{ in/in}$$

The offset line will pass through Q (See figure):

Slope of 0.2% offset

$$= E = 10,529,861.82 \text{ psi}$$

Test for location

$$\text{slope} = \frac{\text{rise}}{\text{run}}$$

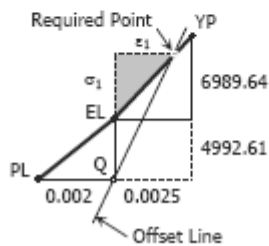

$$10,529,861.82 = \frac{6989.64 + 4992.61}{\text{run}}$$

run = 0.00113793 < 0.0025, therefore,
the required point is just
before YP.

Slope of EL to YP

$$\frac{\sigma_1}{\varepsilon_1} = \frac{6989.64}{0.0025}$$
$$\frac{\sigma_1}{\varepsilon_1} = 2\,795\,856$$
$$\varepsilon_1 = \frac{\sigma_1}{2\,795\,856}$$

For required point

$$E = \frac{4992.61 + \sigma_1}{\varepsilon_1}$$
$$10\,529\,861.82 = \frac{4992.61 + \sigma_1}{\frac{\sigma_1}{2\,795\,856}}$$
$$3.7662\sigma_1 = 4992.61 + \sigma_1$$
$$\sigma_1 = 1804.84 \text{ psi}$$

Yield Strength at 0.2% Offset

$$= EL + \sigma_1$$
$$= 62906.85 + 1804.84$$
$$= 64,711.69 \text{ psi}$$

(e) Ultimate Strength = 73,890.58 psi

(f) Rupture Strength = 67,899.45 psi

Problem 205

A uniform bar of length L , cross-sectional area A , and unit mass ρ is suspended vertically from one end. Show that its total elongation is $\delta = \rho g L^2 / 2E$. If the total mass of the bar is M , show also that $\delta = MgL/2AE$.

Solution 205

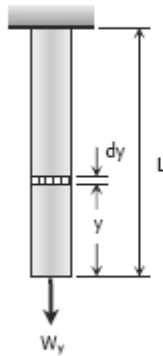

$$\delta = \frac{PL}{AE}$$

From the figure:
 $\delta = ds$
 $P = Wy = (\rho Ay)g$
 $L = dy$

$$d\delta = \frac{(\rho Ay)g \, dy}{AE}$$

$$\delta = \frac{\rho g}{E} \int_0^L y \, dy = \frac{\rho g}{E} \left[\frac{y^2}{2} \right]_0^L$$

$$\delta = \frac{\rho g}{2E} [L^2 - 0^2] = \rho g L^2 / 2E \quad \text{ok!}$$

Given the total mass M :

$$\rho = M/V = M/AL$$

$$\delta = \rho g L^2 / 2E = (M/AL)(g L^2 / 2E)$$

$$\delta = MgL / 2AE \quad \text{ok!}$$

Another Solution:

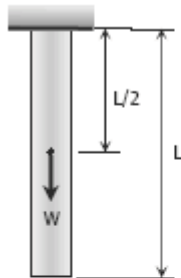

The weight will act at the center of gravity of the bar:

$$\delta = \frac{PL}{AE}$$

Where: $P = W = (\rho AL)g$
 $L = L/2$

$$\delta = \frac{[(\rho AL)g](L/2)}{AE}$$

$$\delta = \frac{\rho g L^2}{2E} \quad \text{ok!}$$

For you to feel the situation, position yourself in pull-up exercise with your hands on the bar and your body hang freely above the ground. Notice that your arms suffer all your weight and your lower body feels no stress (center of weight is approximately just below the chest). If your body is the bar, the elongation will occur at the upper half of it.

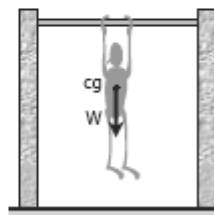

Shearing Deformation

Shearing forces cause shearing deformation. An element subject to shear does not change in length but undergoes a change in shape.

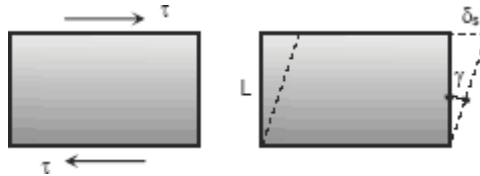

The change in angle at the corner of an original rectangular element is called the **shear strain** and is expressed as

$$\gamma = \frac{\delta_s}{L}$$

The ratio of the shear stress τ and the shear strain γ is called the **modulus of elasticity** in shear or modulus of rigidity and is denoted as G , in MPa.

$$G = \frac{\tau}{\gamma}$$

The relationship between the shearing deformation and the applied shearing force is

$$\delta_s = \frac{VL}{A_s G} = \frac{\tau L}{G}$$

where V is the shearing force acting over an area A_s .

Poisson's Ratio

When a bar is subjected to a tensile loading there is an increase in length of the bar in the direction of the applied load, but there is also a decrease in a lateral dimension perpendicular to the load. The ratio of the sidewise deformation (or strain) to the longitudinal deformation (or strain) is called the Poisson's ratio and is denoted by ν . For most steel, it lies in the range of 0.25 to 0.3, and 0.20 for concrete.

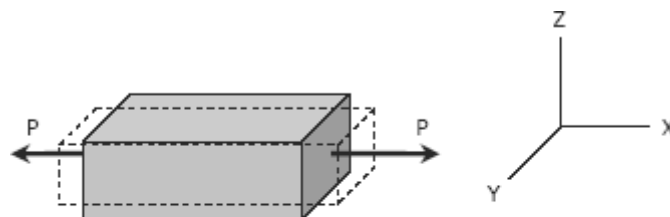

$$\nu = -\frac{\epsilon_y}{\epsilon_x} = -\frac{\epsilon_z}{\epsilon_x}$$

where ε_x is strain in the x-direction and ε_y and ε_z are the strains in the perpendicular direction. The negative sign indicates a decrease in the transverse dimension when ε_x is positive.

BIAXIAL DEFORMATION

If an element is subjected simultaneously by tensile stresses, σ_x and σ_y , in the x and y directions, the strain in the x-direction is σ_x / E and the strain in the y direction is σ_y / E . Simultaneously, the stress in the y direction will produce a lateral contraction on the x direction of the amount $-\nu \varepsilon_y$ or $-\nu \sigma_y / E$. The resulting strain in the x direction will be

$$\varepsilon_x = \frac{\sigma_x}{E} - \nu \frac{\sigma_y}{E} \quad \text{or} \quad \sigma_x = \frac{(\varepsilon_x + \nu \varepsilon_y)E}{1 - \nu^2}$$

and

$$\varepsilon_y = \frac{\sigma_y}{E} - \nu \frac{\sigma_x}{E} \quad \text{or} \quad \sigma_y = \frac{(\varepsilon_y + \nu \varepsilon_x)E}{1 - \nu^2}$$

TRIAXIAL DEFORMATION

If an element is subjected simultaneously by three mutually perpendicular normal stresses σ_x , σ_y , and σ_z , which are accompanied by strains ε_x , ε_y , and ε_z , respectively,

$$\begin{aligned} \varepsilon_x &= \frac{1}{E}[\sigma_x - \nu(\sigma_y + \sigma_z)] \\ \varepsilon_y &= \frac{1}{E}[\sigma_y - \nu(\sigma_x + \sigma_z)] \\ \varepsilon_z &= \frac{1}{E}[\sigma_z - \nu(\sigma_x + \sigma_y)] \end{aligned}$$

Tensile stresses and elongation are taken as positive. Compressive stresses and contraction are taken as negative.

Relationship Between E, G, and ν

The relationship between modulus of elasticity E, shear modulus G and Poisson's ratio ν is:

$$G = \frac{E}{2(1 + \nu)}$$

Bulk Modulus of Elasticity or Modulus of Volume Expansion, K

The bulk modulus of elasticity K is a measure of a resistance of a material to change in volume without change in shape or form. It is given as

$$K = \frac{E}{3(1-2\nu)} = \frac{\sigma}{\Delta V/V}$$

where V is the volume and ΔV is change in volume. The ratio $\Delta V / V$ is called volumetric strain and can be expressed as

$$\frac{\Delta V}{V} = \frac{\sigma}{K} = \frac{3(1-2\nu)}{E}$$

Solved Problems in Shearing Deformation

Problem 222

A solid cylinder of diameter d carries an axial load P. Show that its change in diameter is $4P\nu / \pi E d$.

Solution 222

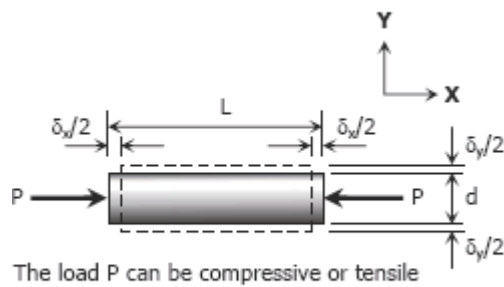

$$\nu = -\frac{\epsilon_y}{\epsilon_x}$$

$$\epsilon_y = -\nu \epsilon_x$$

$$\epsilon_y = -\nu \frac{\sigma_x}{E}$$

$$\frac{\delta_y}{d} = -\nu \frac{-P}{AE}$$

$$\delta_y = \nu \frac{Pd}{\frac{1}{4}\pi d^2 E}$$

$$\delta_y = \frac{4P\nu}{\pi E d} \quad \text{ok!}$$

Problem 223

A rectangular steel block is 3 inches long in the x direction, 2 inches long in the y direction, and 4 inches long in the z direction. The block is subjected to a triaxial loading of three uniformly distributed forces as follows: 48 kips tension in the x direction, 60 kips compression in the y direction, and 54 kips tension in the z direction. If $\nu = 0.30$ and $E = 29 \times 10^6$ psi, determine the single uniformly distributed load in the x direction that would produce the same deformation in the y direction as the original loading.

Solution 223

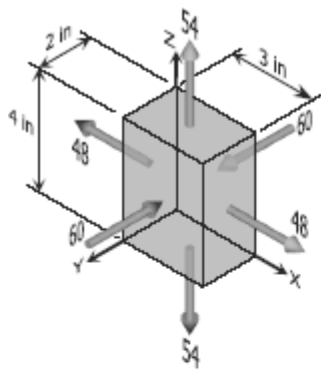

For triaxial deformation (tensile triaxial stresses):
(compressive stresses are negative stresses)

$$\epsilon_y = \frac{1}{E} [\sigma_y - \nu(\sigma_x + \sigma_z)]$$

$$\sigma_x = \frac{P_x}{A_{yz}} = \frac{48}{4(2)} = 6.0 \text{ ksi (tension)}$$

$$\sigma_y = \frac{P_y}{A_{xz}} = \frac{60}{4(3)} = 5.0 \text{ ksi (compression)}$$

$$\sigma_z = \frac{P_z}{A_{xy}} = \frac{54}{2(3)} = 9.0 \text{ ksi (tension)}$$

$$\epsilon_y = \frac{1}{29 \times 10^6} [-5000 - 0.30(6000 + 9000)]$$

$$\epsilon_y = -3.276 \times 10^{-4}$$

ϵ_y is negative, thus tensile force is required in the x-direction to produce the same deformation in the y-direction as the original forces.

For equivalent single force in the x-direction:
(uniaxial stress)

$$\nu = -\frac{\epsilon_y}{\epsilon_x}$$

$$-\nu \epsilon_x = \epsilon_y$$

$$-\nu \frac{\sigma_x}{E} = \epsilon_y$$

$$-0.30 \left(\frac{\sigma_x}{29 \times 10^6} \right) = -3.276 \times 10^{-4}$$

$$\sigma_x = 31\,666.67 \text{ psi}$$

$$\sigma_x = \frac{P_x}{4(2)} = 31\,666.67$$

$$P_x = 253\,333.33 \text{ lb (tension)}$$

$$P_x = 253.33 \text{ kips (tension)}$$

Problem 224

For the block loaded triaxially as described in Prob. 223, find the uniformly distributed load that must be added in the x direction to produce no deformation in the z direction.

Solution 224

$$\epsilon_z = \frac{1}{E} [\sigma_z - \nu(\sigma_x + \sigma_y)]$$

$$\sigma_x = 6.0 \text{ ksi (tension)}$$

$$\sigma_y = 5.0 \text{ ksi (compression)}$$

$$\sigma_z = 9.0 \text{ ksi (tension)}$$

$$\epsilon_z = \frac{1}{29 \times 10^6} [9000 - 0.3(6000 - 5000)]$$

$$\epsilon_z = 2.07 \times 10^{-5}$$

ϵ_z is positive, thus positive stress is needed in the x-direction to eliminate deformation in z-direction.

The application of loads is still simultaneous:

(No deformation means zero strain)

$$\epsilon_z = \frac{1}{E} [\sigma_z - \nu(\sigma_x + \sigma_y)] = 0$$

$$\sigma_z = \nu(\sigma_x + \sigma_y)$$

$$\sigma_y = 5.0 \text{ ksi} \quad \rightarrow \text{(compression)}$$

$$\sigma_z = 9.0 \text{ ksi} \quad \rightarrow \text{(tension)}$$

$$9000 = 0.30(\sigma_x - 5000)$$

$$\sigma_x = 35\,000 \text{ psi}$$

$$\sigma_{added} + 6000 = 35\,000$$

$$\sigma_{added} = 29\,000 \text{ psi}$$

$$\frac{P_{added}}{2(4)} = 29\,000$$

$$P_{added} = 232\,000 \text{ lb}$$

$$P_{added} = 232 \text{ kips}$$

Problem 225

A welded steel cylindrical drum made of a 10-mm plate has an internal diameter of 1.20 m. Compute the change in diameter that would be caused by an internal pressure of 1.5 MPa. Assume that Poisson's ratio is 0.30 and $E = 200 \text{ GPa}$.

Solution 225

σ_y = longitudinal stress

$$\sigma_y = \frac{pD}{4t} = \frac{1.5(1200)}{4(10)}$$

$$\sigma_y = 45 \text{ MPa}$$

σ_x = tangential stress

$$\sigma_x = \frac{pD}{2t} = \frac{1.5(1200)}{2(10)}$$

$$\sigma_x = 90 \text{ MPa}$$

$$\epsilon_x = \frac{\sigma_x}{E} - \nu \frac{\sigma_y}{E}$$

$$\epsilon_x = \frac{90}{200000} - 0.3 \left(\frac{45}{200000} \right)$$

$$\epsilon_x = 3.825 \times 10^{-4}$$

$$\epsilon_x = \frac{\Delta D}{D}$$

$$\Delta D = \epsilon_x D = (3.825 \times 10^{-4})(1200)$$

$$\Delta D = 0.459 \text{ mm}$$

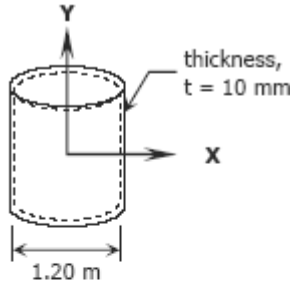

Problem 226

A 2-in.-diameter steel tube with a wall thickness of 0.05 inch just fits in a rigid hole. Find the tangential stress if an axial compressive load of 3140 lb is applied. Assume $\nu = 0.30$ and neglect the possibility of buckling.

Solution 226

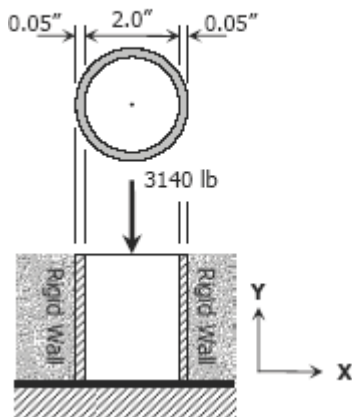

$$\epsilon_x = \frac{\sigma_x}{E} - \nu \frac{\sigma_y}{E} = 0$$

$$\sigma_x = \nu \sigma_y$$

where σ_x = tangential stress
 σ_y = longitudinal stress

$$\sigma_y = \frac{P_y}{A} = \frac{3140}{\pi(2)(0.05)}$$

$$\sigma_y = 31400/\pi \text{ psi}$$

$$\sigma_x = 0.30(31400/\pi)$$

$$\sigma_x = 9430/\pi \text{ psi}$$

$$\sigma_x = 2298.5 \text{ psi}$$

Problem 227

A 150-mm-long bronze tube, closed at its ends, is 80 mm in diameter and has a wall thickness of 3 mm. It fits without clearance in an 80-mm hole in a rigid block. The tube is then subjected to an internal pressure of 4.00 MPa. Assuming $\nu = 1/3$ and $E = 83$ GPa, determine the tangential stress in the tube.

Solution 227

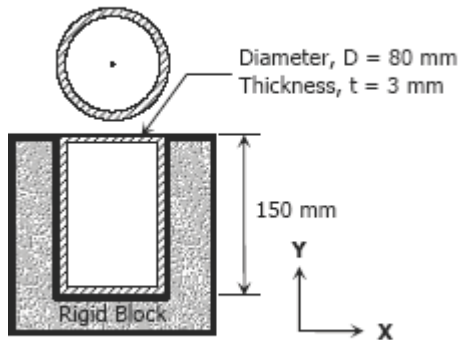

Longitudinal stress:

$$\sigma_y = \frac{pD}{4t} = \frac{4(80)}{4(3)}$$

$$\sigma_y = \frac{80}{3} \text{ MPa}$$

The strain in the x -direction is:

$$\epsilon_x = \frac{\sigma_x}{E} - \nu \frac{\sigma_y}{E} = 0$$

$$\sigma_x = \nu \sigma_y = \text{tangential stress}$$

$$\sigma_x = \frac{1}{3} \left(\frac{80}{3} \right)$$

$$\sigma_x = 8.89 \text{ MPa}$$

Problem 228

A 6-in.-long bronze tube, with closed ends, is 3 in. in diameter with a wall thickness of 0.10 in. With no internal pressure, the tube just fits between two rigid end walls. Calculate the longitudinal and tangential stresses for an internal pressure of 6000 psi. Assume $\nu = 1/3$ and $E = 12 \times 10^6$ psi.

Solution 228

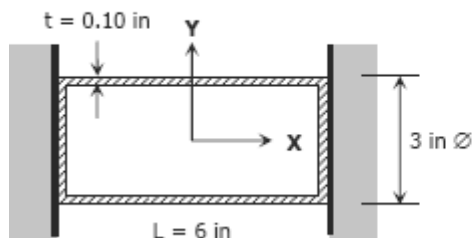

$$\epsilon_x = \frac{\sigma_x}{E} - \nu \frac{\sigma_y}{E} = 0$$

$$\sigma_x = \nu \sigma_y = \sigma_l \rightarrow \text{longitudinal stress}$$

$$\sigma_t = \sigma_y \rightarrow \text{tangential stress}$$

$$\sigma_t = \frac{pD}{2t} = \frac{6000(3)}{2(0.10)}$$

$$\sigma_t = 90,000 \text{ psi}$$

$$\sigma_l = \nu \sigma_y = \frac{1}{3} (90,000)$$

$$\sigma_l = 30,000 \text{ psi}$$

Statically Indeterminate Members

When the reactive forces or the internal resisting forces over a cross section exceed the number of independent equations of equilibrium, the structure is called **statically indeterminate**. These cases require the use of additional relations that depend on the elastic deformations in the members.

Solved Problems in Statically Indeterminate Members

Problem 233

A steel bar 50 mm in diameter and 2 m long is surrounded by a shell of a cast iron 5 mm thick. Compute the load that will compress the combined bar a total of 0.8 mm in the length of 2 m. For steel, $E = 200$ GPa, and for cast iron, $E = 100$ GPa.

Solution 233

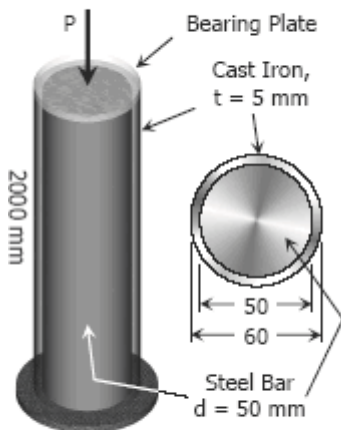

$$\delta = \frac{PL}{AE}$$

$$\delta = \delta_{\text{cast iron}} = \delta_{\text{steel}} = 0.8 \text{ mm}$$

$$\delta_{\text{cast iron}} = \frac{P_{\text{cast iron}}(2000)}{\left[\frac{1}{4}\pi(60^2 - 50^2)\right](100000)} = 0.8$$

$$P_{\text{cast iron}} = 11\,000\pi \text{ N}$$

$$\delta_{\text{steel}} = \frac{P_{\text{steel}}(2000)}{\left[\frac{1}{4}\pi(50^2)\right](200000)} = 0.8$$

$$P_{\text{steel}} = 50\,000\pi \text{ N}$$

$$\sum F_V = 0$$

$$P = P_{\text{cast iron}} + P_{\text{steel}}$$

$$P = 11\,000\pi + 50\,000\pi$$

$$P = 61\,000\pi \text{ N}$$

$$P = 191.64 \text{ kN}$$

Problem 234

A reinforced concrete column 200 mm in diameter is designed to carry an axial compressive load of 300 kN. Determine the required area of the reinforcing steel if the allowable stresses are 6 MPa and 120 MPa for the concrete and steel, respectively. Use $E_{co} = 14 \text{ GPa}$ and $E_{st} = 200 \text{ GPa}$.

Solution 234

$$\delta_{co} = \delta_{st} = \delta$$

$$\left(\frac{PL}{AE}\right)_{co} = \left(\frac{PL}{AE}\right)_{st}$$

$$\left(\frac{\sigma L}{E}\right)_{co} = \left(\frac{\sigma L}{E}\right)_{st}$$

$$\frac{\sigma_{co} L}{14000} = \frac{\sigma_{st} L}{200000}$$

$$100\sigma_{co} = 7\sigma_{st}$$

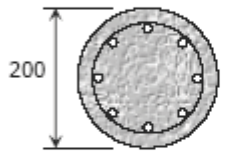

When $\sigma_{st} = 120 \text{ MPa}$

$$100\sigma_{co} = 7(120)$$

$$\sigma_{co} = 8.4 \text{ MPa} > 6 \text{ MPa (not ok!)}$$

When $\sigma_{co} = 6 \text{ MPa}$

$$100(6) = 7\sigma_{st}$$

$$\sigma_{st} = 85.71 \text{ MPa} < 120 \text{ MPa (ok!)}$$

Use $\sigma_{co} = 6 \text{ MPa}$ and $\sigma_{st} = 85.71 \text{ MPa}$

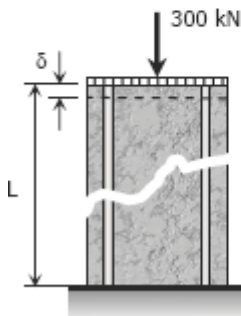

$$\sum F_V = 0$$

$$P_{st} + P_{co} = 300$$

$$\sigma_{st} A_{st} + \sigma_{co} A_{co} = 300$$

$$85.71 A_{st} + 6\left[\frac{1}{4}\pi(200)^2 - A_{st}\right] = 300(1000)$$

$$79.71 A_{st} + 60\,000\pi = 300\,000$$

$$A_{st} = 1398.9 \text{ mm}^2$$

Problem 235

A timber column, 8 in. \times 8 in. in cross section, is reinforced on each side by a steel plate 8 in. wide and t in. thick. Determine the thickness t so that the column will support an axial load of 300 kips without exceeding a maximum timber stress of 1200 psi or a maximum steel stress of 20 ksi. The moduli of elasticity are 1.5×10^6 psi for timber, and 29×10^6 psi for steel.

Solution 235

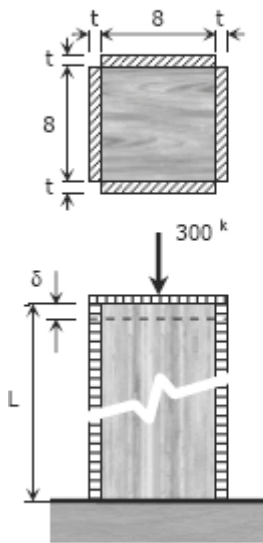

$$\delta_{st} = \delta_t$$

$$\left(\frac{\sigma L}{E}\right)_{st} = \left(\frac{\sigma L}{E}\right)_{timber}$$

$$\frac{\sigma_{st} L}{29 \times 10^6} = \frac{\sigma_{timber} L}{1.5 \times 10^6}$$

$$1.5 \sigma_{st} = 29 \sigma_{timber}$$

When $\sigma_{timber} = 1200$ psi

$$1.5 \sigma_{st} = 29(1200)$$

$$\sigma_{st} = 23\,200 \text{ psi} = 23.2 \text{ ksi} > 20 \text{ ksi (not ok!)}$$

When $\sigma_{st} = 20$ ksi

$$1.5(20 \times 1000) = 29 \sigma_{timber}$$

$$\sigma_{timber} = 1034.48 \text{ psi} < 1200 \text{ psi (ok!)}$$

Use $\sigma_{st} = 20$ ksi and $\sigma_{timber} = 1.03$ ksi

$$\sum F_V = 0$$

$$F_{steel} + F_{timber} = 300$$

$$\sigma_{st} A_{st} + \sigma_{timber} A_{timber} = 300$$

$$20[4(8t)] + 1.03(8^2) = 300$$

$$t = 0.365 \text{ in}$$

Problem 236

A rigid block of mass M is supported by three symmetrically spaced rods as shown in fig P-236. Each copper rod has an area of 900 mm^2 ; $E = 120 \text{ GPa}$; and the allowable stress is 70 MPa . The steel rod has an area of 1200 mm^2 ; $E = 200 \text{ GPa}$; and the allowable stress is 140 MPa . Determine the largest mass M which can be supported.

Figure P-236 and P-237

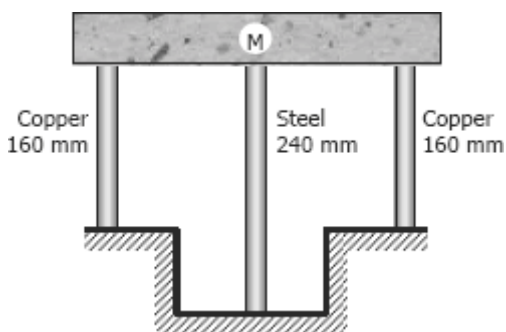

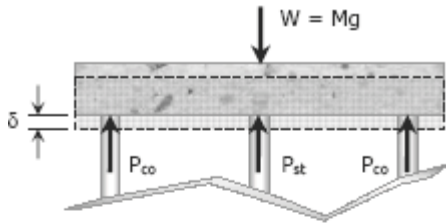
Solution 236

$$\delta_{co} = \delta_{st}$$

$$\left(\frac{\sigma L}{E}\right)_{co} = \left(\frac{\sigma L}{E}\right)_{st}$$

$$\frac{\sigma_{co}(160)}{120000} = \frac{\sigma_{st}(240)}{200000}$$

$$10\sigma_{co} = 9\sigma_{st}$$

When $\sigma_{st} = 140$ MPa

$$\sigma_{co} = \frac{9}{10}(140)$$

$$\sigma_{co} = 126 \text{ MPa} > 70 \text{ MPa (not ok!)}$$

When $\sigma_{co} = 70$ MPa

$$\sigma_{st} = \frac{10}{9}(70)$$

$$\sigma_{st} = 77.78 \text{ MPa} < 140 \text{ MPa (ok!)}$$

Use $\sigma_{co} = 70$ MPa and $\sigma_{st} = 77.78$ MPa

$$\sum F_V = 0$$

$$2P_{co} + P_{st} = W$$

$$2(\sigma_{co}A_{co}) + \sigma_{st}A_{st} = Mg$$

$$2[70(900)] + 77.78(1200) = M(9.81)$$

$$M = 22\,358.4 \text{ kg}$$

Problem 237

In Prob. 236, how should the lengths of the two identical copper rods be changed so that each material will be stressed to its allowable limit?

Solution 237

Use $\sigma_{co} = 70$ MPa and $\sigma_{st} = 140$ MPa

$$\delta_{co} = \delta_{st}$$

$$\left(\frac{\sigma L}{E}\right)_{co} = \left(\frac{\sigma L}{E}\right)_{st}$$

$$\frac{70L_{co}}{120000} = \frac{140(240)}{200000}$$

$$L_{co} = 288 \text{ mm}$$

Problem 238

The lower ends of the three bars in Fig. P-238 are at the same level before the uniform rigid block weighing 40 kips is attached. Each steel bar has a length of 3 ft, and area of 1.0 in.², and $E = 29 \times 10^6$ psi. For the bronze bar, the area is 1.5 in.² and $E = 12 \times 10^6$ psi. Determine (a) the length of the bronze bar so that the load on each steel bar is twice the load on the bronze bar, and (b) the length of the bronze that will make the steel stress twice the bronze stress.

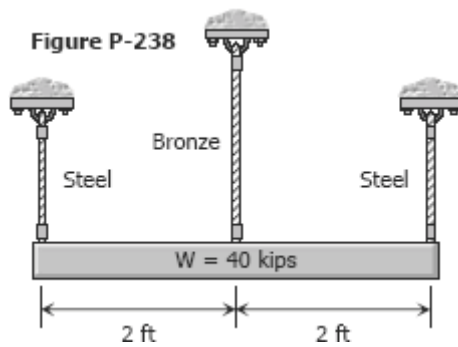

Solution 238

(a) Condition: $P_{st} = 2P_{br}$

$$\sum F_V = 0$$

$$2P_{st} + P_{br} = 40$$

$$2(2P_{br}) + P_{br} = 40$$

$$P_{br} = 8 \text{ kips}$$

$$P_{st} = 2(8) = 16 \text{ kips}$$

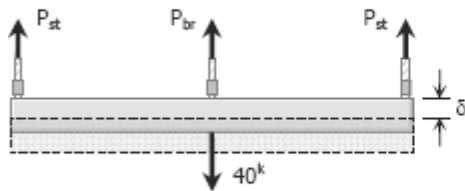

$$\delta_{br} = \delta_{st}$$

$$\left(\frac{PL}{AE}\right)_{br} = \left(\frac{PL}{AE}\right)_{st}$$

$$\frac{8000L_{br}}{1.5(12 \times 10^6)} = \frac{16000(3 \times 12)}{1.0(29 \times 10^6)}$$

$$L_{br} = 44.69 \text{ in}$$

$$L_{br} = 3.72 \text{ ft}$$

(b) Condition: $\sigma_{st} = 2\sigma_{br}$

$$\sum F_V = 0$$

$$2P_{st} + P_{br} = 40$$

$$2(\sigma_{st}A_{st}) + \sigma_{br}A_{br} = 40$$

$$2[(2\sigma_{br})A_{st}] + \sigma_{br}A_{br} = 40$$

$$4\sigma_{br}(1.0) + \sigma_{br}(1.5) = 40$$

$$\sigma_{br} = 7.27 \text{ ksi}$$

$$\sigma_{st} = 2(7.27) = 14.54 \text{ ksi}$$

$$\delta_{br} = \delta_{st}$$

$$\left(\frac{\sigma L}{E}\right)_{br} = \left(\frac{\sigma L}{E}\right)_{st}$$

$$\frac{7.27(1000)L_{br}}{12 \times 10^6} = \frac{14.54(1000)(3 \times 12)}{29 \times 10^6}$$

$$L_{br} = 29.79 \text{ in}$$

$$L_{br} = 2.48 \text{ ft}$$

Problem 239

The rigid platform in Fig. P-239 has negligible mass and rests on two steel bars, each 250.00 mm long. The center bar is aluminum and 249.90 mm long. Compute the stress in the aluminum bar after the center load $P = 400 \text{ kN}$ has been applied. For each steel bar, the area is 1200 mm^2 and $E = 200 \text{ GPa}$. For the aluminum bar, the area is 2400 mm^2 and $E = 70 \text{ GPa}$.

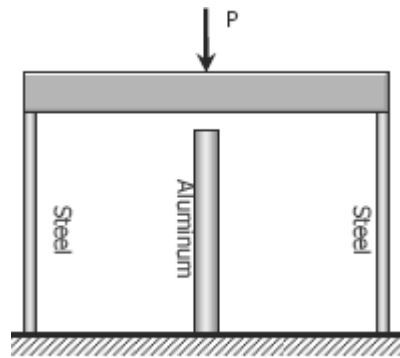
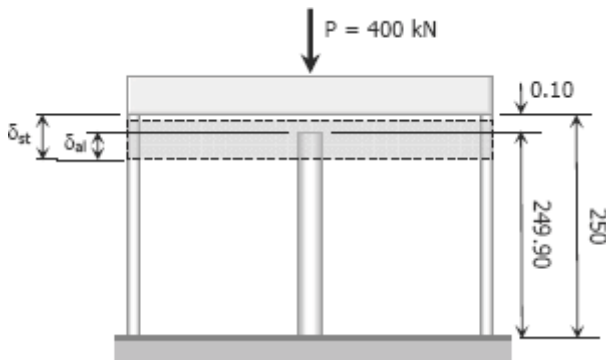

Figure P-239

Solution 239



$$\delta_{st} = \delta_{al} + 0.10$$

$$\left(\frac{\sigma L}{E}\right)_{st} = \left(\frac{\sigma L}{E}\right)_{al} + 0.10$$

$$\frac{\sigma_{st}(250)}{200\,000} = \frac{\sigma_{al}(249.90)}{70\,000} + 0.10$$

$$0.00125\sigma_{st} = 0.00357\sigma_{al} + 0.10$$

$$\sigma_{st} = 2.856\sigma_{al} + 80$$

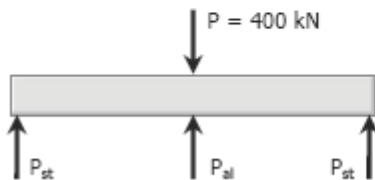

$$\sum F_V = 0$$

$$2P_{st} + P_{al} = 400\,000$$

$$2\sigma_{st}A_{st} + \sigma_{al}A_{al} = 400\,000$$

$$2(2.856\sigma_{al} + 80)1200 + \sigma_{al}(2400) = 400\,000$$

$$9254.4\sigma_{al} + 192\,000 = 400\,000$$

$$\sigma_{al} = 22.48 \text{ MPa}$$

Problem 240

Three steel eye-bars, each 4 in. by 1 in. in section, are to be assembled by driving rigid 7/8-in.-diameter drift pins through holes drilled in the ends of the bars. The center-line spacing between the holes is 30 ft in the two outer bars, but 0.045 in. shorter in the middle bar. Find the shearing stress developed in the drip pins. Neglect local deformation at the holes.

Solution 240

Middle bar is 0.045 inch shorter between holes than outer bars.

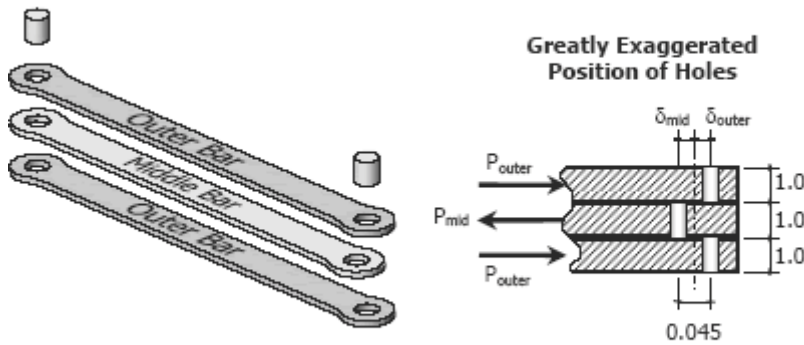

$$\sum F_H = 0$$

$$P_{mid} = 2P_{outer}$$

$$\delta_{outer} + \delta_{mid} = 0.045$$

$$\left(\frac{PL}{AE}\right)_{outer} + \left(\frac{PL}{AE}\right)_{mid} = 0.045$$

$$\frac{P_{outer}(30 \times 12)}{[1.0(4.0)]E} + \frac{P_{mid}(30 \times 12 - 0.045)}{[1.0(4.0)]E} = 0.045$$

$$360P_{outer} + 359.955P_{mid} = 0.18E$$

$$360P_{outer} + 359.955(2P_{outer}) = 0.18E$$

(For steel: $E = 29 \times 10^6$ psi)

$$1079.91P_{outer} = 0.18(29 \times 10^6)$$

$$P_{outer} = 4833.74 \text{ lb}$$

$$P_{mid} = 2(4833.74)$$

$$P_{mid} = 9667.48 \text{ lb}$$

Use shear force $V = P_{mid}$

Shearing stress of drip pins (double shear):

$$\tau = \frac{V}{A} = \frac{9667.48}{2\left[\frac{1}{4}\pi\left(\frac{7}{8}\right)^2\right]}$$

$$\tau = 8038.54 \text{ psi}$$

Problem 241

As shown in Fig. P-241, three steel wires, each 0.05 in.^2 in area, are used to lift a load $W = 1500 \text{ lb}$. Their unstressed lengths are 74.98 ft, 74.99 ft, and 75.00 ft. (a) What stress exists in the longest wire? (b) Determine the stress in the shortest wire if $W = 500 \text{ lb}$.

Solution 241

Let $L_1 = 74.98$ ft; $L_2 = 74.99$ ft; and $L_3 = 75.00$ ft

- (a) Bring L_1 and L_2 into $L_3 = 75$ ft length:
(For steel: $E = 29 \times 10^6$ psi)

$$\delta = \frac{PL}{AE}$$

For L_1 :

$$(75 - 74.98)(12) = \frac{P_1(74.98 \times 12)}{0.05(29 \times 10^6)}$$

$$P_1 = 386.77 \text{ lb}$$

For L_2

$$(75 - 74.99)(12) = \frac{P_2(74.99 \times 12)}{0.05(29 \times 10^6)}$$

$$P_2 = 193.36 \text{ lb}$$

Let $P = P_3$ (Load carried by L_3)

$P + P_2$ (Total load carried by L_2)

$P + P_1$ (Total load carried by L_1)



Figure P-241

$$\sum F_V = 0$$

$$(P + P_1) + (P + P_2) + P = W$$

$$3P + 386.77 + 193.36 = 1500$$

$$P = 306.62 \text{ lb} = P_3$$

$$\sigma_3 = \frac{P_3}{A} = \frac{306.62}{0.05}$$

$$\sigma_3 = 6132.47 \text{ psi}$$

- (b) From the above solution:

$$P_1 + P_2 = 580.13 \text{ lb} > 500 \text{ lb} \text{ (} L_3 \text{ carries no load)}$$

Bring L_1 into $L_2 = 74.99$ ft

$$\left[\delta = \frac{PL}{AE} \right] \quad (74.99 - 74.98)(12) = \frac{P_1(74.98 \times 12)}{0.05(29 \times 10^6)}$$

$$P_1 = 193.38 \text{ lb}$$

Let $P = P_2$ (Load carried by L_2)

$P + P_1$ (Total load carried by L_1)

$$\sum F_V = 0$$

$$(P + P_1) + P = 500$$

$$2P + 193.38 = 500$$

$$P = 153.31 \text{ lb}$$

$$P + P_1 = 153.31 + 193.38$$

$$P + P_1 = 346.69 \text{ lb}$$

$$\sigma = \frac{P + P_1}{A} = \frac{346.69}{0.05}$$

$$\sigma = 6933.8 \text{ psi}$$

Problem 242

The assembly in Fig. P-242 consists of a light rigid bar AB, pinned at O, that is attached to the steel and aluminum rods. In the position shown, bar AB is horizontal and there is a gap, $\Delta = 5$ mm, between the lower end of the steel rod and its pin support at C. Compute the stress in the aluminum rod when the lower end of the steel rod is attached to its support.

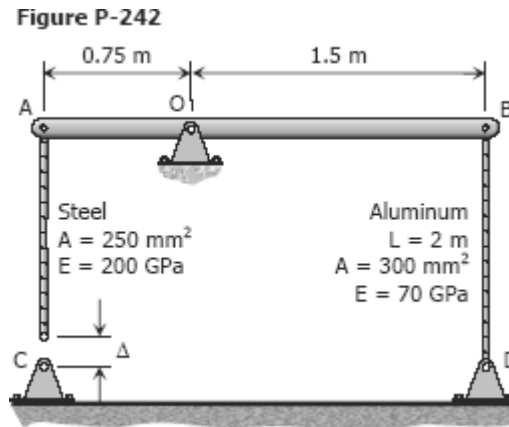

Solution 242

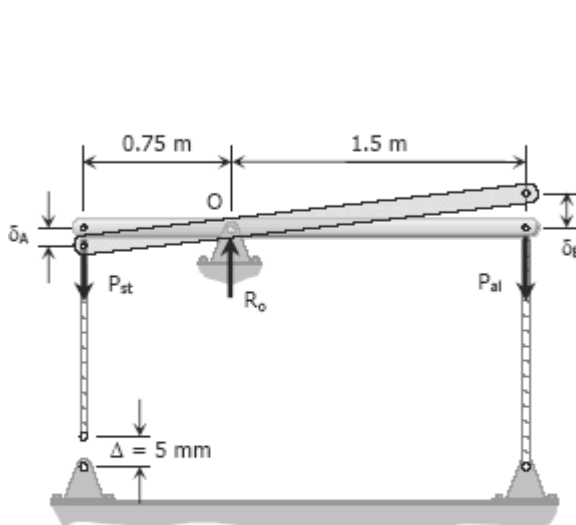

$$\begin{aligned}\sum M_O &= 0 \\ 0.75P_{st} &= 1.5P_{al} \\ P_{st} &= 2P_{al} \\ \sigma_{st}A_{st} &= 2(\sigma_{al}A_{al}) \\ \sigma_{st} &= \frac{2(\sigma_{al}A_{al})}{A_{st}} \\ \sigma_{st} &= \frac{2[\sigma_{al}(300)]}{250} \\ \sigma_{st} &= 2.4\sigma_{al}\end{aligned}$$

$$\delta_{al} = \delta_B$$

By ratio and proportion:

$$\begin{aligned}\frac{\delta_A}{0.75} &= \frac{\delta_B}{1.5} \\ \delta_A &= 0.5\delta_B \\ \delta_A &= 0.5\delta_{al}\end{aligned}$$

$$\Delta = \delta_{st} + \delta_A$$

$$5 = \delta_{st} + 0.5\delta_{al}$$

$$5 = \frac{\sigma_{st}(2000 - 5)}{250(200000)} + 0.5 \left[\frac{\sigma_{al}(2000)}{300(70000)} \right]$$

$$5 = (3.99 \times 10^{-5}) \sigma_{st} + (4.76 \times 10^{-5}) \sigma_{al}$$

$$\sigma_{al} = 105000 - 0.8379\sigma_{st}$$

$$\sigma_{al} = 105000 - 0.8379(2.4\sigma_{al})$$

$$3.01096\sigma_{al} = 105000$$

$$\sigma_{al} = 34872.6 \text{ MPa}$$

Problem 243

A homogeneous rod of constant cross section is attached to unyielding supports. It carries an axial load P applied as shown in Fig. P-243. Prove that the reactions are given by $R_1 = Pb/L$ and $R_2 = Pa/L$.

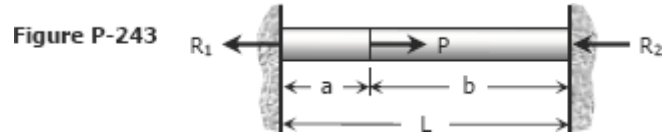

Solution 243

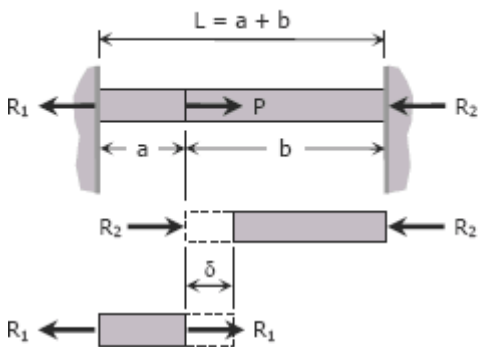

$$\begin{aligned} \sum F_H &= 0 \\ R_1 + R_2 &= P \\ R_2 &= P - R_1 \end{aligned}$$

$$\begin{aligned} \delta_1 &= \delta_2 = \delta \\ \left(\frac{PL}{AE}\right)_1 &= \left(\frac{PL}{AE}\right)_2 \\ \frac{R_1 a}{AE} &= \frac{R_2 b}{AE} \\ R_1 a &= R_2 b \end{aligned}$$

$$\begin{aligned} R_1 a &= (P - R_1) b \\ R_1 a &= P b - R_1 b \\ R_1 (a + b) &= P b \\ R_1 L &= P b \\ R_1 &= P b / L \quad \text{ok!} \end{aligned}$$

$$\begin{aligned} R_2 &= P - P b / L \\ R_2 &= \frac{P(L - b)}{L} \\ R_2 &= P a / L \quad \text{ok!} \end{aligned}$$

Problem 244

A homogeneous bar with a cross sectional area of 500 mm^2 is attached to rigid supports. It carries the axial loads $P_1 = 25 \text{ kN}$ and $P_2 = 50 \text{ kN}$, applied as shown in Fig. P-244. Determine the stress in segment BC. (Hint: Use the results of Prob. 243, and compute the reactions caused by P_1 and P_2 acting separately. Then use the principle of superposition to compute the reactions when both loads are applied.)

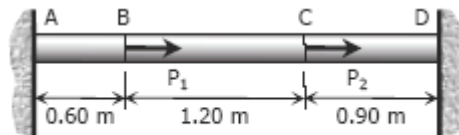
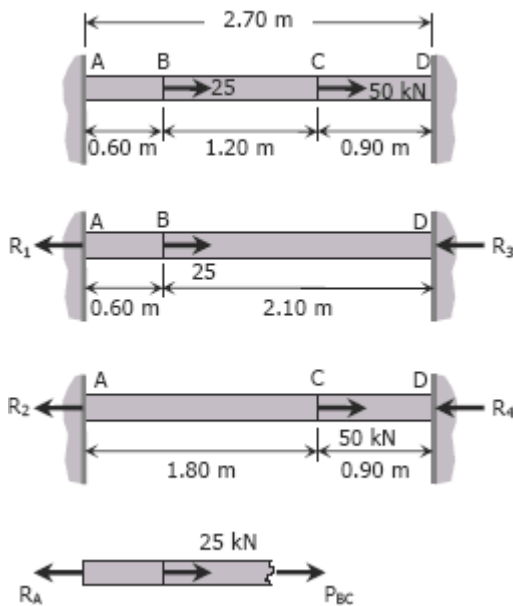

Figure P-244

Solution 244



From the result of Prob. 243:

$$R_1 = 25(2.10)/2.70$$

$$R_1 = 19.44 \text{ kN}$$

$$R_2 = 50(0.90)/2.70$$

$$R_2 = 16.67 \text{ kN}$$

$$R_A = R_1 + R_2$$

$$R_A = 19.44 + 16.67$$

$$R_A = 36.11 \text{ kN}$$

For segment BC

$$P_{BC} + 25 = R_A$$

$$P_{BC} + 25 = 36.11$$

$$P_{BC} = 11.11 \text{ kN}$$

$$\sigma_{BC} = \frac{P_{BC}}{A} = \frac{11.11(1000)}{500}$$

$$\sigma_{BC} = 22.22 \text{ MPa}$$

Problem 245

The composite bar in Fig. P-245 is firmly attached to unyielding supports. Compute the stress in each material caused by the application of the axial load $P = 50$ kips.

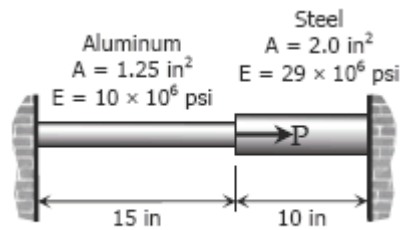
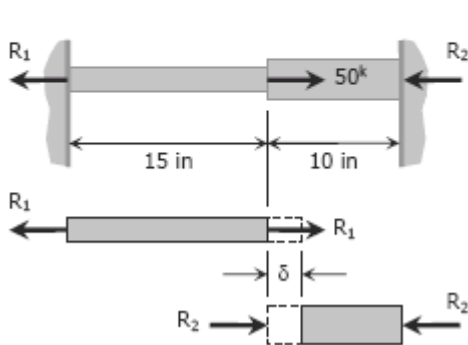

Figure P-245 and P-246

Solution 245

$$\begin{aligned}\sum F_H &= 0 \\ R_1 + R_2 &= 50\,000 \\ R_1 &= 50\,000 - R_2\end{aligned}$$



$$\begin{aligned}\delta_{al} &= \delta_{st} = \delta \\ \left(\frac{PL}{AE}\right)_{al} &= \left(\frac{PL}{AE}\right)_{st} \\ \frac{R_1(15)}{1.25(10 \times 10^6)} &= \frac{R_2(10)}{2.0(29 \times 10^6)} \\ R_2 &= 6.96R_1 \\ R_2 &= 6.96(50\,000 - R_2) \\ 7.96R_2 &= 348\,000 \\ R_2 &= 43\,718.59\text{ lb}\end{aligned}$$

$$\sigma_{st} = \frac{R_2}{A_{st}} = \frac{43\,718.59}{2.0}$$

$$\sigma_{st} = 21\,859.30\text{ psi}$$

$$R_1 = 50\,000 - 43\,718.59$$

$$R_1 = 6\,281.41\text{ lb}$$

$$\sigma_{al} = \frac{R_1}{A_{al}} = \frac{6\,281.41}{1.25}$$

$$\sigma_{al} = 5\,025.12\text{ psi}$$

Problem 246

Referring to the composite bar in Prob. 245, what maximum axial load P can be applied if the allowable stresses are 10 ksi for aluminum and 18 ksi for steel.

Solution 246

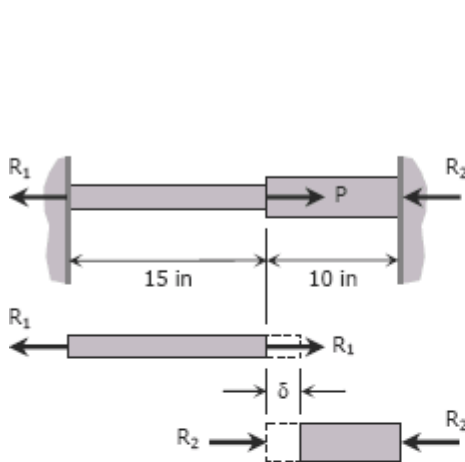

$$\delta_{st} = \delta_{al} = \delta$$

$$\left(\frac{\sigma L}{E}\right)_{st} = \left(\frac{\sigma L}{E}\right)_{al}$$

$$\frac{\sigma_{st}(10)}{29 \times 10^6} = \frac{\sigma_{al}(15)}{10 \times 10^6}$$

$$\sigma_{st} = 4.35\sigma_{al}$$

When $\sigma_{al} = 10$ ksi
 $\sigma_{st} = 4.35(10)$
 $\sigma_{st} = 43.5$ ksi > 18 ksi (not ok!)

When $\sigma_{st} = 18$ ksi
 $18 = 4.35\sigma_{al}$
 $\sigma_{al} = 4.14$ ksi < 10 ksi (ok!)

Use $\sigma_{al} = 4.14$ ksi and $\sigma_{st} = 18$ ksi

$$\sum F_H = 0$$

$$P = R_1 + R_2$$

$$P = \sigma_{al}A_{al} + \sigma_{st}A_{st}$$

$$P = 4.14(1.25) + 18(2.0)$$

$$P = 41.17 \text{ kips}$$

Problem 247

The composite bar in Fig. P-247 is stress-free before the axial loads P_1 and P_2 are applied. Assuming that the walls are rigid, calculate the stress in each material if $P_1 = 150$ kN and $P_2 = 90$ kN.

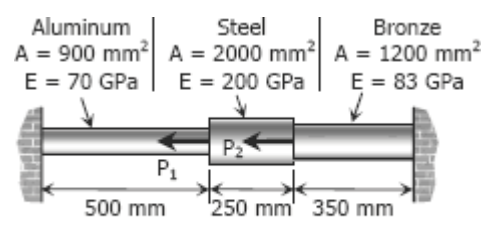
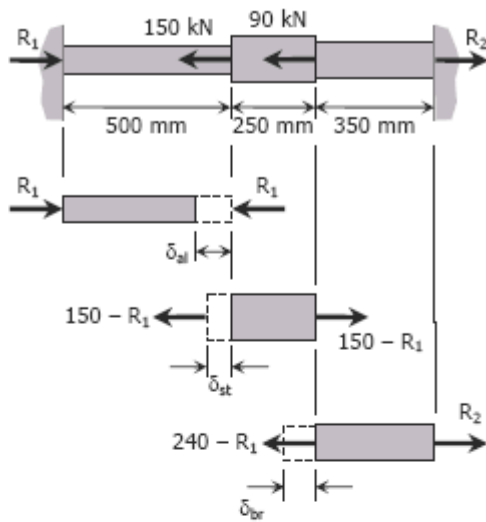

Figure P-247 and P-248

Solution 247

From the FBD of each material shown:



δ_{al} is shortening

δ_{st} and δ_{br} are lengthening

$$R_2 = 240 - R_1$$

$$P_{al} = R_1$$

$$P_{st} = 150 - R_1$$

$$P_{br} = R_2 = 240 - R_1$$

$$\delta_{al} = \delta_{st} + \delta_{br}$$

$$\left(\frac{PL}{AE}\right)_{al} = \left(\frac{PL}{AE}\right)_{st} + \left(\frac{PL}{AE}\right)_{br}$$

$$\frac{R_1(500)}{900(70000)} = \frac{(150 - R_1)(250)}{2000(200000)} + \frac{(240 - R_1)(350)}{1200(83000)}$$

$$\frac{R_1}{126000} = \frac{150 - R_1}{1600000} + \frac{(240 - R_1)7}{1992000}$$

$$\frac{1}{63} R_1 = \frac{1}{800} (150 - R_1) + \frac{7}{996} (240 - R_1)$$

$$\left(\frac{1}{63} + \frac{1}{800} + \frac{7}{996}\right) R_1 = \frac{1}{800} (150) + \frac{7}{996} (240)$$

$$R_1 = 77.60 \text{ kN}$$

$$P_{al} = R_1 = 77.60 \text{ kN}$$

$$P_{st} = 150 - 77.60 = 72.40 \text{ kN}$$

$$P_{br} = 240 - 77.60 = 162.40 \text{ kN}$$

$$\sigma = P/A$$

$$\begin{aligned} \sigma_{al} &= 77.60(1000)/900 \\ &= \mathbf{86.22 \text{ MPa}} \end{aligned}$$

$$\begin{aligned} \sigma_{st} &= 72.40(1000)/2000 \\ &= \mathbf{36.20 \text{ MPa}} \end{aligned}$$

$$\begin{aligned} \sigma_{br} &= 162.40(1000)/1200 \\ &= \mathbf{135.33 \text{ MPa}} \end{aligned}$$

Problem 248

Solve Prob. 247 if the right wall yields 0.80 mm.

Solution 248

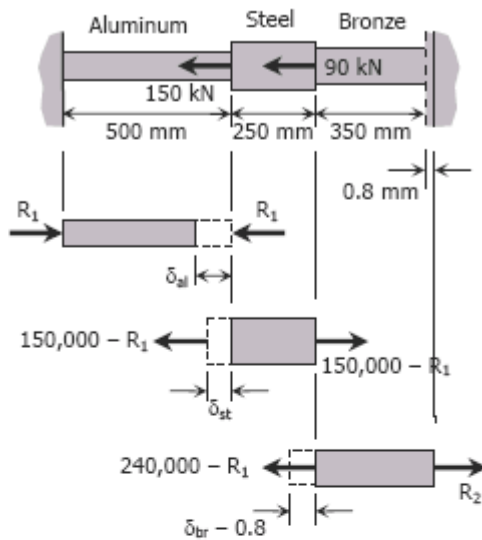

$$\delta_{al} = \delta_{st} + (\delta_{br} + 0.8)$$

$$\left(\frac{PL}{AE}\right)_{al} = \left(\frac{PL}{AE}\right)_{st} + \left(\frac{PL}{AE}\right)_{br} + 0.8$$

$$\frac{R_1(500)}{900(70000)} = \frac{(150000 - R_1)(250)}{2000(200000)} + \frac{(240000 - R_1)(350)}{1200(83000)} + 0.8$$

$$\frac{R_1}{126000} = \frac{150000 - R_1}{1600000} + \frac{7(240000 - R_1)}{1992000} + 0.8$$

$$\frac{1}{63} R_1 = \frac{1}{800} (150000 - R_1) + \frac{7}{996} (240000 - R_1) + 1600$$

$$\left(\frac{1}{63} + \frac{1}{800} + \frac{7}{996}\right) R_1 = \frac{1}{800} (150000) + \frac{7}{996} (240000) + 1600$$

$$R_1 = 143\,854 \text{ N} = 143.854 \text{ kN}$$

$$P_{al} = R_1 = 143.854 \text{ kN}$$

$$P_{st} = 150 - R_1 = 150 - 143.854 = 6.146 \text{ kN}$$

$$P_{br} = R_2 = 240 - R_1 = 240 - 143.854 = 96.146 \text{ kN}$$

$$\sigma = P/A$$

$$\sigma_{al} = 143.854(1000)/900 = 159.84 \text{ MPa}$$

$$\sigma_{st} = 6.146(1000)/2000 = 3.073 \text{ MPa}$$

$$\sigma_{br} = 96.146(1000)/1200 = 80.122 \text{ MPa}$$

Problem 249

There is a radial clearance of 0.05 mm when a steel tube is placed over an aluminum tube. The inside diameter of the aluminum tube is 120 mm, and the wall thickness of each tube is 2.5 mm. Compute the contact pressure and tangential stress in each tube when the aluminum tube is subjected to an internal pressure of 5.0 MPa.

Solution 249

Internal pressure of aluminum tube to cause contact with the steel:

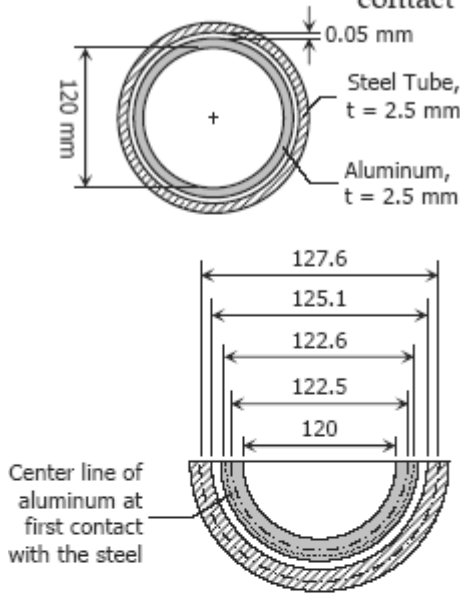

$$\delta_{al} = \left(\frac{\sigma L}{E} \right)_{al}$$

$$\pi(122.6 - 122.5) = \frac{\sigma_1(122.5\pi)}{70000}$$

$$\sigma_1 = 57.143 \text{ MPa}$$

$$\frac{p_1 D}{2t} = 57.143$$

$$\frac{p_1(120)}{2(2.5)} = 57.143$$

$$p_1 = 2.381 \text{ MPa}$$

→ pressure that causes aluminum to contact with the steel, further increase of pressure will expand both aluminum and steel tubes.

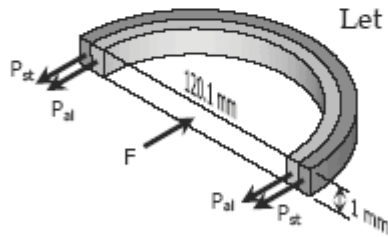

FBD for $p \geq 2.381 \text{ MPa}$

Let p_c = contact pressure between steel and aluminum tubes

$$2P_{st} + 2P_{al} = F$$

$$2P_{st} + 2P_{al} = 5.0(120.1)(1)$$

$$P_{st} + P_{al} = 300.25 \rightarrow \text{Equation (1)}$$

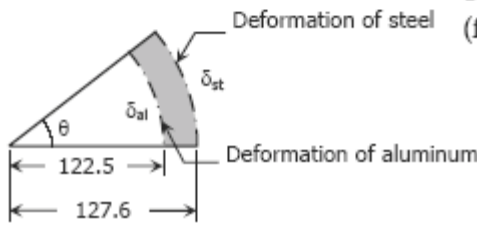

Geometric relation of deformations

The relationship of deformations is (from the figure):

$$\delta_{st} = 127.6\theta$$

$$\theta = \delta_{st} / 127.6$$

$$\delta_{al} = 122.5\theta$$

$$\delta_{al} = 122.5(\delta_{st} / 127.6)$$

$$\delta_{al} = 0.96\delta_{st}$$

$$\left(\frac{PL}{AE} \right)_{al} = 0.96 \left(\frac{PL}{AE} \right)_{st}$$

$$\frac{P_{al}(122.5\pi)}{2.5(70000)} = 0.96 \left[\frac{P_{st}(127.6\pi)}{2.5(200000)} \right]$$

$$P_{al} = 0.35P_{st} \rightarrow \text{Equation (2)}$$

From Equation (1)

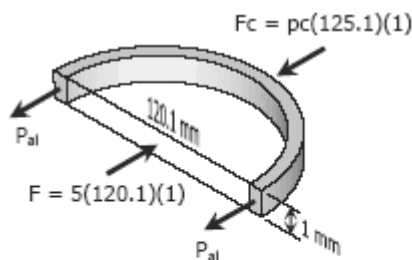

$$P_{st} + 0.35P_{st} = 300.25$$

$$P_{st} = 222.41 \text{ N}$$

$$P_{al} = 0.35(222.41)$$

$$P_{al} = 77.84 \text{ N}$$

Contact Force

$$F_c + 2P_{st} = F$$

$$p_c(125.1)(1) + 2(77.84) = 5(120.1)(1)$$

$$p_c = 3.56 \text{ MPa}$$

Problem 250

In the assembly of the bronze tube and steel bolt shown in Fig. P-250, the pitch of the bolt thread is $p = 1/32$ in.; the cross-sectional area of the bronze tube is 1.5 in.^2 and of steel bolt is $\frac{3}{4} \text{ in.}^2$. The nut is turned until there is a compressive stress of 4000 psi in the bronze tube. Find the stresses if the nut is given one additional turn. How many turns of the nut will reduce these stresses to zero? Use $E_{br} = 12 \times 10^6$ psi and $E_{st} = 29 \times 10^6$ psi.

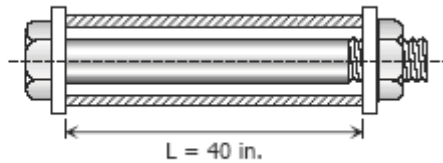

Figure P-250

Solution 250

$$P_{st} = P_{br}$$

$$A_{st} \sigma_{st} = P_{br} \sigma_{br}$$

$$\frac{3}{4} \sigma_{st} = 1.5 \sigma_{br}$$

$$\sigma_{st} = 2 \sigma_{br}$$

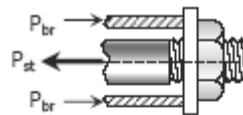

For one turn of the nut:

$$\delta_{st} + \delta_{br} = \frac{1}{32}$$

$$\left(\frac{\sigma L}{E} \right)_{st} + \left(\frac{\sigma L}{E} \right)_{br} = \frac{1}{32}$$

$$\frac{\sigma_{st}(40)}{29 \times 10^6} + \frac{\sigma_{br}(40)}{12 \times 10^6} = \frac{1}{32}$$

$$\sigma_{st} + \frac{29}{12} \sigma_{br} = 22\,656.25$$

$$2\sigma_{br} + \frac{29}{12} \sigma_{br} = 22\,656.25$$

$$\sigma_{br} = 5129.72 \text{ psi}$$

$$\sigma_{st} = 2(5129.72) = 10\,259.43 \text{ psi}$$

Initial stresses:

$$\sigma_{br} = 4000 \text{ psi}$$

$$\sigma_{st} = 2(4000) = 8000 \text{ psi}$$

Final stresses:

$$\sigma_{br} = 4000 + 5129.72 = 9129.72 \text{ psi}$$

$$\sigma_{st} = 2(9129.72) = 18\,259.4 \text{ psi}$$

Required number of turns to reduce σ_{br} to zero:

$$n = \frac{9129.72}{5129.72} = 1.78 \text{ turns}$$

The nut must be turned back by 1.78 turns

Problem 251

The two vertical rods attached to the light rigid bar in Fig. P-251 are identical except for length. Before the load W was attached, the bar was horizontal and the rods were stress-free. Determine the load in each rod if $W = 6600$ lb.

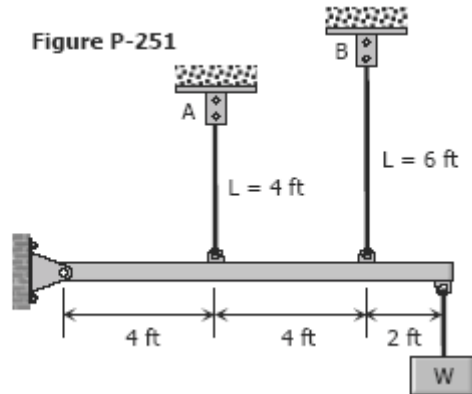

Solution 251

$$\begin{aligned}\sum M_{pin\ support} &= 0 \\ 4P_A + 8P_B &= 10(6600) \\ P_A + 2P_B &= 16500 \quad \rightarrow (1)\end{aligned}$$

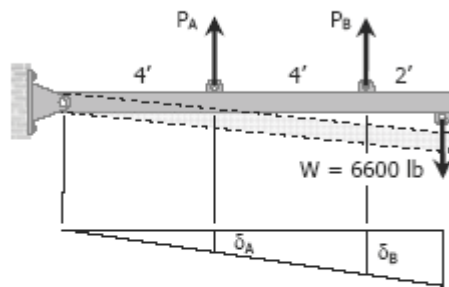

$$\begin{aligned}\frac{\delta_A}{4} &= \frac{\delta_B}{8} \\ \delta_A &= 0.5\delta_B \\ \left(\frac{PL}{AE}\right)_A &= 0.5\left(\frac{PL}{AE}\right)_B \\ \frac{P_A(4)}{AE} &= \frac{0.5P_B(6)}{AE} \\ P_A &= 0.75P_B\end{aligned}$$

$$\begin{aligned}\text{From equation (1)} \\ 0.75P_B + 2P_B &= 16500 \\ P_B &= 6000 \text{ lb}\end{aligned}$$

$$\begin{aligned}P_A &= 0.75(6000) \\ P_A &= 4500 \text{ lb}\end{aligned}$$

Problem 252

The light rigid bar ABCD shown in Fig. P-252 is pinned at B and connected to two vertical rods. Assuming that the bar was initially horizontal and the rods stress-free, determine the stress in each rod after the load $P = 20$ kips is applied.

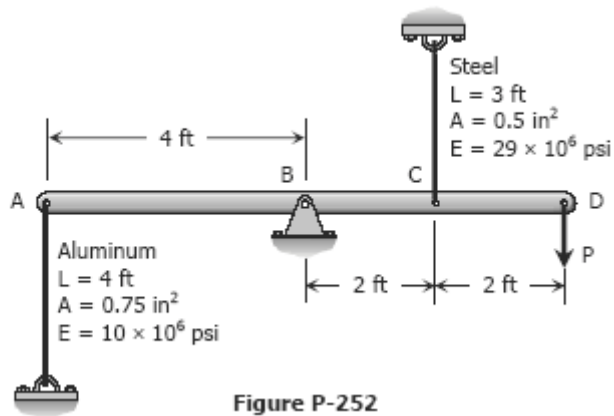
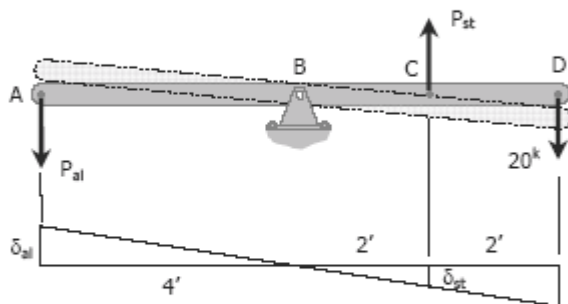

Figure P-252

Solution 252

$$\begin{aligned} \sum M_B = 0 \\ 4P_{al} + 2P_{st} &= 4(20\,000) \\ 4(\sigma_{al} A_{al}) + 2\sigma_{st} A_{st} &= 80\,000 \\ 4[\sigma_{al} (0.75)] + 2[\sigma_{st} (0.5)] &= 80\,000 \\ 3\sigma_{al} + \sigma_{st} &= 80\,000 \quad \rightarrow (1) \\ \frac{\delta_{st}}{2} &= \frac{\delta_{al}}{4} \end{aligned}$$



$$\begin{aligned} \delta_{st} &= 0.5\delta_{al} \\ \left(\frac{\sigma L}{E}\right)_{st} &= 0.5\left(\frac{\sigma L}{E}\right)_{al} \\ \frac{\sigma_{st}(3)}{29 \times 10^6} &= 0.5\left[\frac{P_{al}(4)}{10 \times 10^6}\right] \\ \sigma_{st} &= \frac{29}{15} \sigma_{al} \end{aligned}$$

From equation (1)

$$3\sigma_{al} + \frac{29}{15} \sigma_{al} = 80\,000$$

$$\sigma_{al} = 16\,216.22 \text{ psi}$$

$$\sigma_{al} = 16.22 \text{ ksi}$$

$$\sigma_{st} = \frac{29}{15} (16.22)$$

$$\sigma_{st} = 31.35 \text{ ksi}$$

Problem 253

As shown in Fig. P-253, a rigid beam with negligible weight is pinned at one end and attached to two vertical rods. The beam was initially horizontal before the load $W = 50$ kips was applied. Find the vertical movement of W .

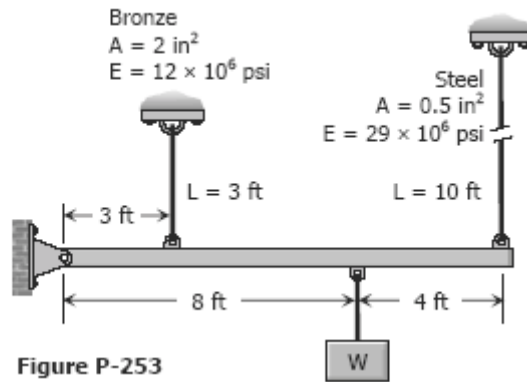
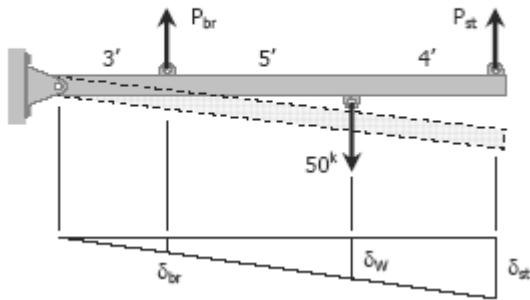

Figure P-253

Solution 253

$$\begin{aligned} \sum M_{pin\ support} &= 0 \\ 3P_{br} + 12P_{st} &= 8(50\ 000) \\ 3P_{br} + 12P_{st} &= 400\ 000 \quad \rightarrow (1) \end{aligned}$$



$$\frac{\delta_{st}}{12} = \frac{\delta_{br}}{3}; \delta_{st} = 4\delta_{br}$$

$$\left(\frac{PL}{AE}\right)_{st} = 4\left(\frac{PL}{AE}\right)_{br}$$

$$\frac{P_{st}(10)}{0.5(29 \times 10^6)} = 4\left[\frac{P_{br}(3)}{2(12 \times 10^6)}\right]$$

$$P_{st} = 0.725P_{br}$$

From equation (1)

$$3P_{br} + 12(0.725P_{br}) = 400\ 000$$

$$P_{br} = 34\ 188.03\ \text{lb}$$

$$\delta_{br} = \left(\frac{PL}{AE}\right)_{br} = \frac{34\ 188.03(3 \times 12)}{2(12 \times 10^6)}$$

$$\delta_{br} = 0.0513\ \text{in}$$

$$\frac{\delta_W}{8} = \frac{\delta_{br}}{3}$$

$$\delta_W = \frac{8}{3} \delta_{br}$$

$$\delta_W = \frac{8}{3} (0.0513)$$

$$\delta_W = 0.1368 \text{ in}$$

Check by δ_{st} :

$$P_{st} = 0.725P_{br} = 0.725(34\ 188.03)$$

$$P_{st} = 24\ 786.32 \text{ lb}$$

$$\delta_{st} = \left(\frac{PL}{AE} \right)_{st}$$

$$\delta_{st} = \frac{24\ 786.32(10 \times 12)}{0.5(29 \times 10^6)}$$

$$\delta_{st} = 0.2051 \text{ in}$$

$$\frac{\delta_W}{8} = \frac{\delta_{st}}{12}$$

$$\delta_W = \frac{2}{3} \delta_{st}$$

$$\delta_W = \frac{2}{3} (0.2051) = 0.1368 \text{ in} \quad \text{ok!}$$

Problem 254

As shown in Fig. P-254, a rigid bar with negligible mass is pinned at O and attached to two vertical rods. Assuming that the rods were initially stress-free, what maximum load P can be applied without exceeding stresses of 150 MPa in the steel rod and 70 MPa in the bronze rod.

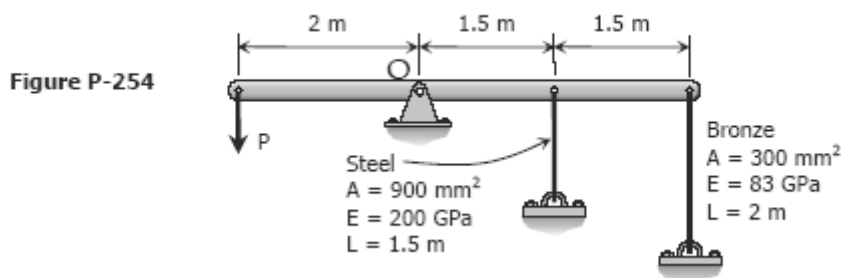

Solution 254

$$\begin{aligned} \sum M_O &= 0 \\ 2P &= 1.5P_{st} + 3P_{br} \\ 2P &= 1.5(\sigma_{st}A_{st}) + 3(\sigma_{br}A_{br}) \\ 2P &= 1.5[\sigma_{st}(900)] + 3[\sigma_{br}(300)] \\ 2P &= 1350\sigma_{st} + 900\sigma_{br} \\ P &= 675\sigma_{st} + 450\sigma_{br} \end{aligned}$$

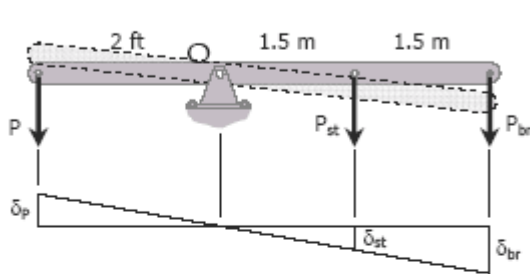

$$\begin{aligned} \frac{\delta_{br}}{3} &= \frac{\delta_{st}}{1.5} \\ \delta_{br} &= 2\delta_{st} \\ \left(\frac{\sigma L}{E}\right)_{br} &= 2\left(\frac{\sigma L}{E}\right)_{st} \\ \frac{\sigma_{br}(2)}{83} &= 2\left[\frac{\sigma_{st}(1.5)}{200}\right] \\ \sigma_{br} &= 0.6225\sigma_{st} \end{aligned}$$

When $\sigma_{st} = 150 \text{ MPa}$
 $\sigma_{br} = 0.6225(150)$
 $\sigma_{br} = 93.375 \text{ MPa} > 70 \text{ MPa (not ok!)}$

When $\sigma_{br} = 70 \text{ MPa}$
 $70 = 0.6225\sigma_{st}$
 $\sigma_{st} = 112.45 \text{ MPa} < 150 \text{ MPa (ok!)}$

Use $\sigma_{st} = 112.45 \text{ MPa}$ and $\sigma_{br} = 70 \text{ MPa}$

$$\begin{aligned} P &= 675\sigma_{st} + 450\sigma_{br} \\ P &= 675(112.45) + 450(70) \\ P &= 107\,403.75 \text{ N} \\ P &= 107.4 \text{ kN} \end{aligned}$$

Problem 255

Shown in Fig. P-255 is a section through a balcony. The total uniform load of 600 kN is supported by three rods of the same area and material. Compute the load in each rod. Assume the floor to be rigid, but note that it does not necessarily remain horizontal.

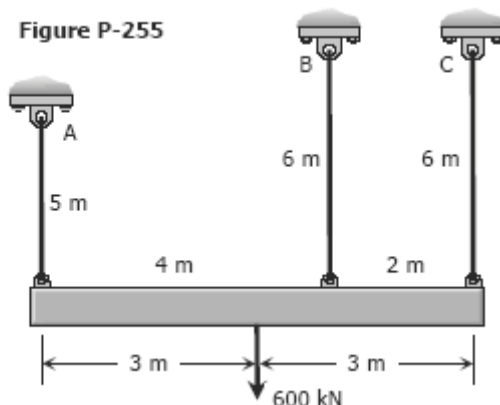

Solution 255

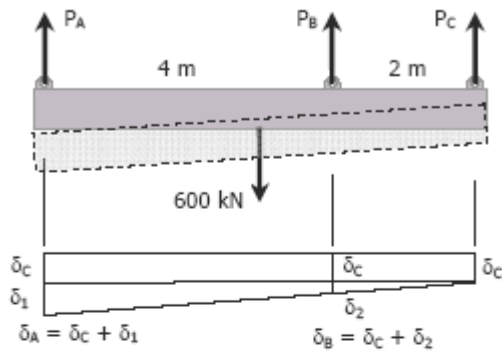

$$\delta_B = \delta_C + \delta_2$$

$$\delta_2 = \delta_B - \delta_C$$

$$\frac{\delta_1}{6} = \frac{\delta_2}{2}; \delta_1 = 3\delta_2$$

$$\delta_A = \delta_C + \delta_1 = \delta_C + 3\delta_2$$

$$\delta_A = \delta_C + 3(\delta_B - \delta_C)$$

$$\delta_A = 3\delta_B - 2\delta_C$$

$$\left(\frac{PL}{AE}\right)_A = 3\left(\frac{PL}{AE}\right)_B - 2\left(\frac{PL}{AE}\right)_C$$

$$\frac{P_A(5)}{AE} = \frac{3P_B(6)}{AE} - \frac{2P_C(6)}{AE}$$

$$P_A = 3.6P_B - 2.4P_C \quad \rightarrow (1)$$

$$[\sum F_V = 0] \quad P_A + P_B + P_C = 600$$

$$(3.6P_B - 2.4P_C) + P_B + P_C = 600$$

$$4.6P_B - 1.4P_C = 600 \quad \rightarrow (2)$$

$$[\sum M_A = 0] \quad 4P_B + 6P_C = 3(600)$$

$$P_B = 450 - 1.5P_C \quad \rightarrow (3)$$

Substitute $P_B = 450 - 1.5P_C$ to (2)

$$4.6(450 - 1.5P_C) - 1.4P_C = 600$$

$$8.3P_C = 1470$$

$$P_C = 177.11 \text{ kN}$$

From (3)

$$P_B = 450 - 1.5(177.11)$$

$$P_B = 184.34 \text{ kN}$$

From (1)

$$P_A = 3.6(184.34) - 2.4(177.11)$$

$$P_A = 238.56 \text{ kN}$$

Problem 256

Three rods, each of area 250 mm^2 , jointly support a 7.5 kN load, as shown in Fig. P-256. Assuming that there was no slack or stress in the rods before the load was applied, find the stress in each rod. Use $E_{st} = 200 \text{ GPa}$ and $E_{br} = 83 \text{ GPa}$.

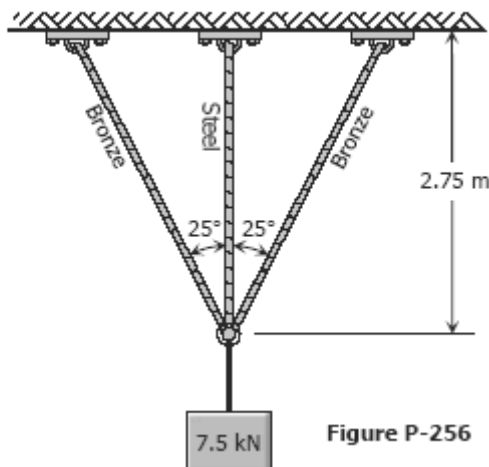
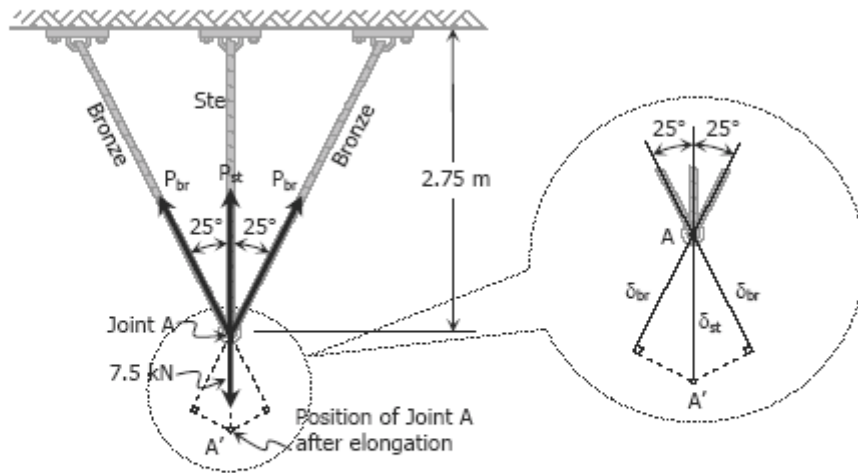

Figure P-256

Solution 256

$$\cos 25^\circ = \frac{2.75}{L_{br}} ; L_{br} = 3.03 \text{ m}$$



$$\begin{aligned} \sum F_V &= 0 \\ 2P_{br} \cos 25^\circ + P_{st} &= 7.5(1000) \\ P_{st} &= 7500 - 1.8126P_{br} \\ \sigma_{st} A_{st} &= 7500 - 1.8126\sigma_{br} A_{br} \\ \sigma_{st} (250) &= 7500 - 1.8126[\sigma_{br} (250)] \end{aligned}$$

$$\sigma_{st} = 30 - 1.8126 \sigma_{br} \rightarrow (1)$$

$$\cos 25^\circ = \frac{\delta_{br}}{\delta_{st}}$$

$$\delta_{br} = 0.9063 \delta_{st}$$

$$\left(\frac{\sigma L}{E} \right)_{br} = 0.9063 \left(\frac{\sigma L}{E} \right)_{st}$$

$$\frac{\sigma_{br} (3.03)}{83} = 0.9063 \left[\frac{\sigma_{st} (2.75)}{200} \right]$$

$$\sigma_{br} = 0.3414 \sigma_{st} \rightarrow (2)$$

From equation (1)

$$\sigma_{st} = 30 - 1.8126(0.3414\sigma_{st})$$

$$\sigma_{st} = 18.53 \text{ MPa}$$

From equation (2)

$$\sigma_{br} = 0.3414(18.53)$$

$$\sigma_{br} = 6.33 \text{ MPa}$$

Problem 257

Three bars AB, AC, and AD are pinned together as shown in Fig. P-257. Initially, the assembly is stressfree. Horizontal movement of the joint at A is prevented by a short horizontal strut AE. Calculate the stress in each bar and the force in the strut AE when the assembly is used to support the load $W = 10$ kips. For each steel bar, $A = 0.3 \text{ in.}^2$ and $E = 29 \times 10^6 \text{ psi}$. For the aluminum bar, $A = 0.6 \text{ in.}^2$ and $E = 10 \times 10^6 \text{ psi}$.

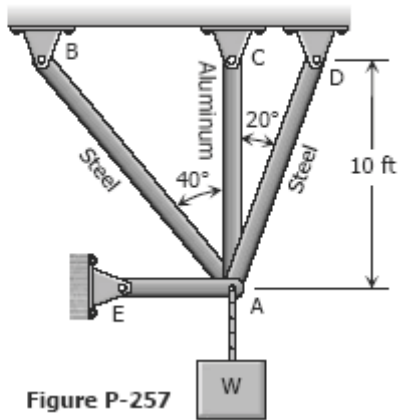

Solution 257

$$\cos 40^\circ = 10 / L_{AB}; L_{AB} = 13.05 \text{ ft}$$

$$\cos 20^\circ = 10 / L_{AD}; L_{AD} = 10.64 \text{ ft}$$

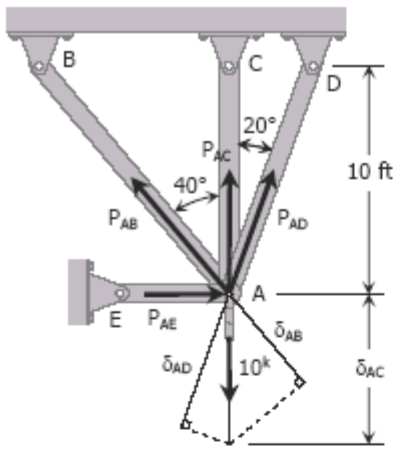

$$\sum F_V = 0$$

$$P_{AB} \cos 40^\circ + P_{AC} + P_{AD} \cos 20^\circ = 10(1000)$$

$$0.7660P_{AB} + P_{AC} + 0.9397P_{AD} = 10\,000 \rightarrow (1)$$

$$\delta_{AB} = \cos 40^\circ \delta_{AC} = 0.7660 \delta_{AC}$$

$$\left(\frac{PL}{AE}\right)_{AB} = 0.7660 \left(\frac{PL}{AE}\right)_{AC}$$

$$\frac{P_{AB}(13.05)}{0.3(29 \times 10^6)} = 0.7660 \left[\frac{P_{AC}(10)}{0.6(10 \times 10^6)} \right]$$

$$P_{AB} = 0.8511P_{AC} \rightarrow (2)$$

$$\delta_{AD} = \cos 20^\circ \delta_{AC} = 0.9397 \delta_{AC}$$

$$\left(\frac{PL}{AE}\right)_{AD} = 0.9397 \left(\frac{PL}{AE}\right)_{AC}$$

$$\frac{P_{AD}(10.64)}{0.3(29 \times 10^6)} = 0.9397 \left[\frac{P_{AC}(10)}{0.6(10 \times 10^6)} \right]$$

$$P_{AD} = 1.2806P_{AC} \rightarrow (3)$$

Substitute P_{AB} of (2) and P_{AD} of (3) to (1)

$$0.7660(0.8511P_{AC}) + P_{AC} + 0.9397(1.2806P_{AC}) = 10\,000$$

$$2.8553P_{AC} = 10\,000$$

$$P_{AC} = 3\,502.23 \text{ lb}$$

$$P_{AB} = 0.8511(3\,502.23) \rightarrow \text{from (2)}$$

$$P_{AB} = 2\,980.75 \text{ lb}$$

$$P_{AD} = 1.2806(3\,502.23) \rightarrow \text{from (3)}$$

$$P_{AD} = 4\,484.96 \text{ lb}$$

Stresses:

$$\sigma = P/A$$

$$\sigma_{AB} = 2980.75/0.3 = 9\,935.83 \text{ psi}$$

$$\sigma_{AC} = 3502.23/0.6 = 5\,837.05 \text{ psi}$$

$$\sigma_{AD} = 4484.96/0.3 = 14\,949.87 \text{ psi}$$

$$\sum F_H = 0$$

$$P_{AE} + P_{AD} \sin 20^\circ = P_{AB} \sin 40^\circ$$

$$P_{AE} = 2\,980.75 \sin 40^\circ - 4\,484.96 \sin 20^\circ$$

$$P_{AE} = 382.04 \text{ lb}$$

Thermal Stress

Temperature changes cause the body to expand or contract. The amount δ_T , is given by

$$\delta_T = \alpha L(T_f - T_i) = \alpha L \Delta T$$

where α is the coefficient of thermal expansion in $m/m^\circ C$, L is the length in meter, and T_i and T_f are the initial and final temperatures, respectively in $^\circ C$.

For steel, $\alpha = 11.25 \times 10^{-6} / ^\circ C$.

If temperature deformation is permitted to occur freely, no load or stress will be induced in the structure. In some cases where temperature deformation is not permitted, an internal stress is created. The internal stress created is termed as thermal stress.

For a homogeneous rod mounted between unyielding supports as shown, the thermal stress is computed as:



deformation due to temperature changes;

$$\delta_T = \alpha L \Delta T$$

deformation due to equivalent axial stress;

$$\delta_P = \frac{PL}{AE} = \frac{\sigma L}{E}$$

$$\delta_T = \delta_P$$

$$\alpha L \Delta T = \frac{\sigma L}{E}$$

$$\sigma = E \alpha \Delta T$$

where σ is the thermal stress in MPa and E is the modulus of elasticity of the rod in MPa.

If the wall yields a distance of x as shown, the following calculations will be made:



$$\delta_T = x + \delta_P$$

$$\alpha L \Delta T = x \frac{\sigma L}{E}$$

where σ represents the thermal stress.

Take note that as the temperature rises above the normal, the rod will be in compression, and if the temperature drops below the normal, the rod is in tension.

Solved Problems in Thermal Stress

Problem 261

A steel rod with a cross-sectional area of 0.25 in^2 is stretched between two fixed points. The tensile load at 70°F is 1200 lb. What will be the stress at 0°F ? At what temperature will the stress be zero? Assume $\alpha = 6.5 \times 10^{-6} \text{ in} / (\text{in}\cdot^\circ\text{F})$ and $E = 29 \times 10^6 \text{ psi}$.

Solution 261

For the stress at 0°C :



$$\delta = \delta_T + \delta_{st}$$

$$\frac{\sigma L}{E} = \alpha L (\Delta T) + \frac{P L}{AE}$$

$$\sigma = \alpha E (\Delta T) + \frac{P}{A}$$

$$\sigma = (6.5 \times 10^{-6})(29 \times 10^6)(70) + \frac{1200}{0.25}$$

$$\sigma = 17\,995 \text{ psi} = 18 \text{ ksi}$$

For the temperature that causes zero stress:

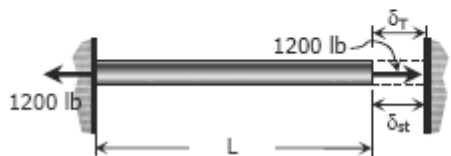

$$\delta_T = \delta_{st}$$

$$\alpha L (\Delta T) = \frac{P L}{AE}$$

$$(6.5 \times 10^{-6})(T - 70) = \frac{1200}{0.25(29 \times 10^6)}$$

$$T = 95.46^\circ\text{C}$$

Problem 262

A steel rod is stretched between two rigid walls and carries a tensile load of 5000 N at 20°C. If the allowable stress is not to exceed 130 MPa at -20°C, what is the minimum diameter of the rod? Assume $\alpha = 11.7 \mu\text{m}/(\text{m}\cdot^\circ\text{C})$ and $E = 200 \text{ GPa}$.

Solution 262

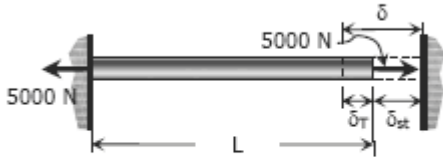

$$\delta = \delta_T + \delta_{st}$$

$$\frac{\sigma L}{E} = \alpha L(\Delta T) + \frac{PL}{AE}$$

$$\sigma = \alpha E(\Delta T) + \frac{P}{A}$$

$$130 = (11.7 \times 10^{-6})(200\,000)(40) + \frac{5000}{A}$$

$$A = \frac{5000}{36.4} = 137.36 \text{ mm}^2$$

$$\frac{1}{4}\pi d^2 = 137.36; \quad d = 13.22 \text{ mm}$$

Problem 263

Steel railroad rails 10 m long are laid with a clearance of 3 mm at a temperature of 15°C. At what temperature will the rails just touch? What stress would be induced in the rails at that temperature if there were no initial clearance? Assume $\alpha = 11.7 \mu\text{m}/(\text{m}\cdot^\circ\text{C})$ and $E = 200 \text{ GPa}$.

Solution 263

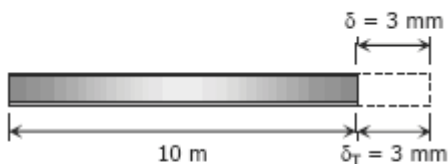

Temperature at which $\delta_T = 3 \text{ mm}$:

$$\delta_T = \alpha L(\Delta T)$$

$$\delta_T = \alpha L(T_f - T_i)$$

$$3 = (11.7 \times 10^{-6})(10\,000)(T_f - 15)$$

$$T_f = 40.64^\circ\text{C}$$

Required stress:

$$\delta = \delta_T$$

$$\frac{\sigma L}{E} = \alpha L(\Delta T)$$

$$\sigma = \alpha E(T_f - T_i)$$

$$\sigma = (11.7 \times 10^{-6})(200\,000)(40.64 - 15)$$

$$\sigma = 60 \text{ MPa}$$

Problem 264

A steel rod 3 feet long with a cross-sectional area of 0.25 in.^2 is stretched between two fixed points. The tensile force is 1200 lb at 40°F. Using $E = 29 \times 10^6 \text{ psi}$ and $\alpha = 6.5 \times 10^{-6} \text{ in.}/(\text{in.}\cdot^\circ\text{F})$, calculate (a) the temperature at which the stress in the bar will be 10 ksi; and (b) the temperature at which the stress will be zero.

Solution 264

(a) Without temperature change:

$$\sigma = P/A = 1200/0.25 = 4800 \text{ psi}$$

$$\sigma = 4.8 \text{ ksi} < 10 \text{ ksi}$$

A drop of temperature is needed to increase the stress to 10 ksi. See accompanying figure.

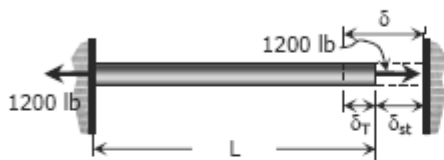

$$\delta = \delta_T + \delta_{st}$$

$$\frac{\sigma L}{E} = \alpha L (\Delta T) + \frac{P L}{AE}$$

$$\sigma = \alpha E (\Delta T) + \frac{P}{A}$$

$$10\,000 = (6.5 \times 10^{-6})(29 \times 10^6)(\Delta T) + \frac{1200}{0.25}$$

$$\Delta T = 27.59^\circ\text{F}$$

Required temperature:

(temperature must drop from 40°F)

$$T = 40 - 27.59 = 12.41^\circ\text{F}$$

(b) From the figure below:

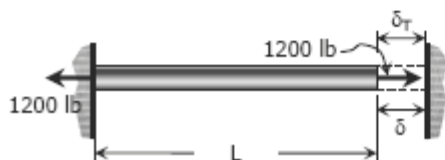

$$\delta = \delta_T$$

$$\frac{P L}{AE} = \alpha L (\Delta T)$$

$$P = \alpha A E (T_f - T_i)$$

$$1200 = (6.5 \times 10^{-6})(0.25)(29 \times 10^6)(T_f - 40)$$

$$T_f = 65.46^\circ\text{F}$$

Problem 265

A bronze bar 3 m long with a cross sectional area of 320 mm² is placed between two rigid walls as shown in Fig. P-265. At a temperature of -20°C, the gap $\Delta = 25$ mm. Find the temperature at which the compressive stress in the bar will be 35 MPa. Use $\alpha = 18.0 \times 10^{-6}$ m/(m·°C) and $E = 80$ GPa.



Solution 265

$$\delta_T = \delta + \Delta$$

$$\alpha L (\Delta T) = \frac{\sigma L}{E} + 2.5$$

$$(18 \times 10^{-6})(3000)(\Delta T) = \frac{35(3000)}{80000} + 2.5$$

$$\Delta T = 70.6^\circ\text{C}$$

$$T = 70.6 - 20$$

$$T = 50.6^\circ\text{C}$$

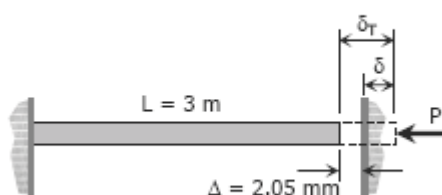

Problem 266

Calculate the increase in stress for each segment of the compound bar shown in Fig. P-266 if the temperature increases by 100°F. Assume that the supports are unyielding and that the bar is suitably braced against buckling.

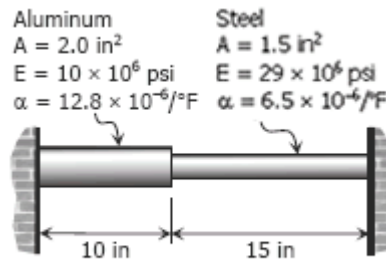
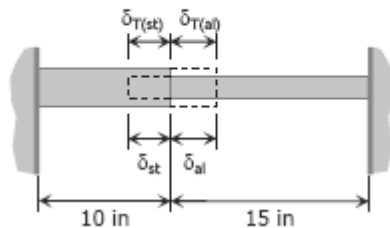

Figure P-266

Solution 266



$$\delta_T = \alpha L \Delta T$$

$$\delta_{T(st)} = (6.5 \times 10^{-6})(15)(100)$$

$$\delta_{T(st)} = 0.00975$$

$$\delta_{T(al)} = (12.8 \times 10^{-6})(10)(100)$$

$$\delta_{T(al)} = 0.0128 \text{ in}$$

$$\delta_{st} + \delta_{al} = \delta_{T(st)} + \delta_{T(al)}$$

$$\left(\frac{PL}{AE}\right)_{st} + \left(\frac{PL}{AE}\right)_{al} = 0.00975 + 0.0128$$

where $P = P_{st} = P_{al}$

$$\frac{P(15)}{1.5(29 \times 10^6)} + \frac{P(10)}{2(10 \times 10^6)} = 0.02255$$

$$P = 26\,691.84 \text{ psi}$$

$$\sigma = \frac{P}{A}$$

$$\sigma_{st} = \frac{26\,691.84}{1.5} = 17\,794.56 \text{ psi}$$

$$\sigma_{al} = \frac{26\,691.84}{2.0} = 13\,345.92 \text{ psi}$$

Problem 267

At a temperature of 80°C, a steel tire 12 mm thick and 90 mm wide that is to be shrunk onto a locomotive driving wheel 2 m in diameter just fits over the wheel, which is at a temperature of 25°C. Determine the contact pressure between the tire and wheel after the assembly cools to 25°C. Neglect the deformation of the wheel caused by the pressure of the tire. Assume $\alpha = 11.7 \mu\text{m}/(\text{m}\cdot^\circ\text{C})$ and $E = 200 \text{ GPa}$.

Solution 267

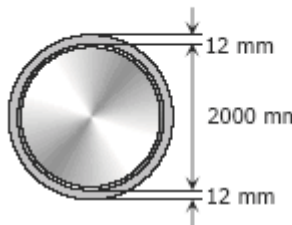

$$\delta = \delta_T$$

$$\frac{PL}{AE} = \alpha L \Delta T$$

$$P = \alpha \Delta T AE$$

$$P = (11.7 \times 10^{-6})(80 - 25)(90 \times 12)(200\,000)$$

$$P = 138\,996 \text{ N}$$

$$F = 2P$$

$$pDL = 2P$$

$$p(2000)(90) = 2(138\,996)$$

$$p = 1.5444 \text{ MPa}$$

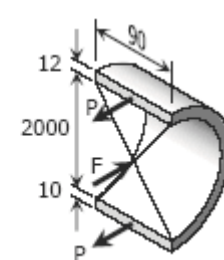

Problem 268

The rigid bar ABC in Fig. P-268 is pinned at B and attached to the two vertical rods. Initially, the bar is horizontal and the vertical rods are stress-free. Determine the stress in the aluminum rod if the temperature of the steel rod is decreased by 40°C. Neglect the weight of bar ABC.

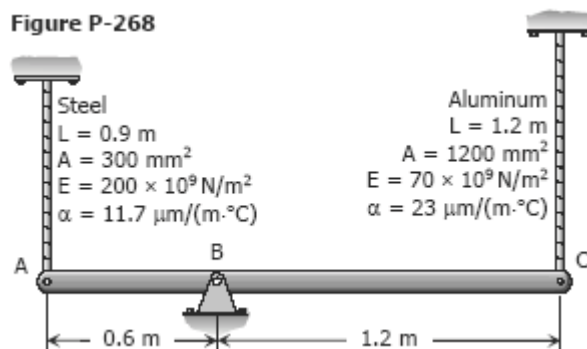

Solution 268

Contraction of steel rod, assuming complete freedom:

$$\begin{aligned}\delta_{T(st)} &= \alpha L \Delta T \\ &= (11.7 \times 10^{-6})(900)(40) \\ &= 0.4212 \text{ mm}\end{aligned}$$

The steel rod cannot freely contract because of the resistance of aluminum rod. The movement of A (referred to as δ_A), therefore, is less than 0.4212 mm. In terms of aluminum, this movement is (by ratio and proportion):

$$\begin{aligned}\frac{\delta_A}{0.6} &= \frac{\delta_{al}}{1.2} \\ \delta_A &= 0.5\delta_{al}\end{aligned}$$

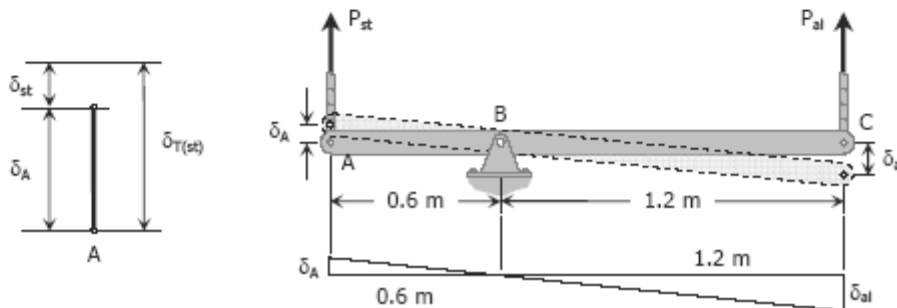

$$\delta_{T(st)} - \delta_{st} = 0.5 \delta_{al}$$

$$0.4212 - \left(\frac{PL}{AE}\right)_{st} = 0.5 \left(\frac{PL}{AE}\right)_{al}$$

$$0.4212 - \frac{P_{st}(900)}{300(200\,000)} = 0.5 \left[\frac{P_{al}(1200)}{1200(70\,000)} \right]$$

$$28080 - P_{st} = 0.4762P_{al} \quad \rightarrow \text{Equation (1)}$$

$$\sum M_B = 0$$

$$0.6P_{st} = 1.2P_{al}$$

$$P_{st} = 2P_{al} \quad \rightarrow \text{Equation (2)}$$

Equations (1) and (2)

$$28080 - 2P_{al} = 0.4762P_{al}$$

$$P_{al} = 11340 \text{ N}$$

$$\sigma_{al} = \frac{P_{al}}{A_{al}} = \frac{11340}{1200}$$

$$\sigma_{al} = 9.45 \text{ MPa}$$

Problem 269

As shown in Fig. P-269, there is a gap between the aluminum bar and the rigid slab that is supported by two copper bars. At 10°C , $\Delta = 0.18$ mm. Neglecting the mass of the slab, calculate the stress in each rod when the temperature in the assembly is increased to 95°C . For each copper bar, $A = 500$ mm², $E = 120$ GPa, and $\alpha = 16.8$ $\mu\text{m}/(\text{m}\cdot^\circ\text{C})$. For the aluminum bar, $A = 400$ mm², $E = 70$ GPa, and $\alpha = 23.1$ $\mu\text{m}/(\text{m}\cdot^\circ\text{C})$.

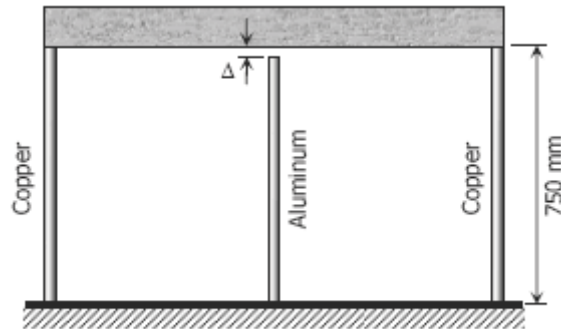

Figure P-269

Solution 269

Assuming complete freedom:

$$\delta_T = \alpha L \Delta T$$

$$\delta_{T(\text{co})} = (16.8 \times 10^{-6})(750)(95 - 10) = 1.071 \text{ mm}$$

$$\delta_{T(\text{al})} = (23.1 \times 10^{-6})(750 - 0.18)(95 - 10) = 1.472 \text{ mm}$$

From the figure:

$$\delta_{T(\text{al})} - \delta_{\text{al}} = \delta_{T(\text{co})} + \delta_{\text{co}}$$

$$1.472 - \left(\frac{PL}{AE}\right)_{\text{al}} = 1.071 + \left(\frac{PL}{AE}\right)_{\text{co}}$$

$$1.472 - \frac{2F(750 - 0.18)}{400(70000)} = 1.071 + \frac{F(750)}{500(120000)}$$

$$0.401 = (6.606 \times 10^{-5}) F$$

$$F = 6070.37 \text{ N}$$

$$P_{\text{co}} = F = 6070.37 \text{ N}$$

$$P_{\text{al}} = 2F = 12140.74 \text{ N}$$

$$\sigma = P/A$$

$$\sigma_{\text{co}} = \frac{6070.37}{500} = 12.14 \text{ MPa}$$

$$\sigma_{\text{al}} = \frac{12140.74}{400} = 30.35 \text{ MPa}$$

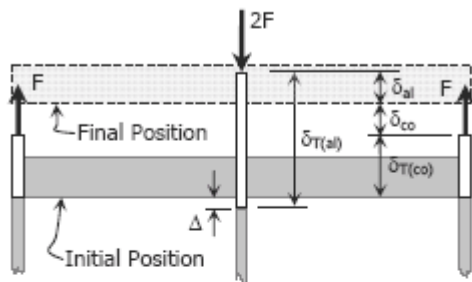

Problem 270

A bronze sleeve is slipped over a steel bolt and held in place by a nut that is turned to produce an initial stress of 2000 psi in the bronze. For the steel bolt, $A = 0.75 \text{ in}^2$, $E = 29 \times 10^6 \text{ psi}$, and $\alpha = 6.5 \times 10^{-6} \text{ in}/(\text{in}\cdot^\circ\text{F})$. For the bronze sleeve, $A = 1.5 \text{ in}^2$, $E = 12 \times 10^6 \text{ psi}$ and $\alpha = 10.5 \times 10^{-6} \text{ in}/(\text{in}\cdot^\circ\text{F})$. After a temperature rise of 100°F , find the final stress in each material.

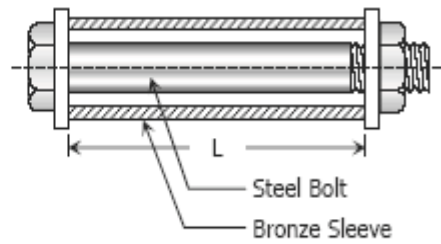
Solution 270

Before temperature change:

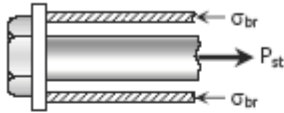

$$\begin{aligned} P_{br} &= \sigma_{br} A_{br} \\ &= 2000(1.5) \\ &= 3000 \text{ lb compression} \end{aligned}$$

$$\begin{aligned} \Sigma F_H &= 0 \\ P_{st} &= P_{br} = 3000 \text{ lb tension} \\ \sigma_{st} &= P_{st}/A_{st} = 3000/0.75 \\ &= 4000 \text{ psi tensile stress} \end{aligned}$$

$$\delta = \frac{\sigma L}{E}$$

$$a = \delta_{br} = \frac{2000L}{12 \times 10^6} = 1.67 \times 10^{-4}L \text{ shortening}$$

$$b = \delta_{st} = \frac{4000L}{29 \times 10^6} = 1.38 \times 10^{-4}L \text{ lengthening}$$

With temperature rise of 100°F:

(Assuming complete freedom)

$$\begin{aligned} \delta_T &= \alpha L \Delta T \\ \delta_{Tbr} &= (10.5 \times 10^{-6})L (100) \\ &= 1.05 \times 10^{-3}L > a \end{aligned}$$

$$\begin{aligned} \delta_{Tst} &= (6.5 \times 10^{-6})L (100) \\ &= 6.5 \times 10^{-4}L \end{aligned}$$

$$\begin{aligned} \delta_{Tbr} - a &= 1.05 \times 10^{-3}L - 1.67 \times 10^{-4}L \\ &= 8.83 \times 10^{-4}L \end{aligned}$$

$$\begin{aligned} \delta_{Tst} + b &= 6.5 \times 10^{-4}L + 1.38 \times 10^{-4}L \\ &= 7.88 \times 10^{-4}L \end{aligned}$$

$$\delta_{Tbr} - a > \delta_{Tst} + b \text{ (see figure below)}$$

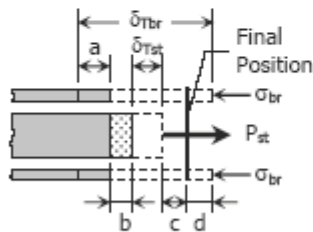

$$\delta_{Tbr} - a - d = b + \delta_{Tst} + c$$

$$\begin{aligned} 1.05 \times 10^{-3}L - 1.67 \times 10^{-4}L - \left(\frac{\sigma L}{E} \right)_{br} \\ = 1.38 \times 10^{-4}L + 6.5 \times 10^{-4}L + \left(\frac{PL}{AE} \right)_{st} \end{aligned}$$

$$\begin{aligned} 8.83 \times 10^{-4}L - \frac{\sigma_{br}L}{12 \times 10^6} \\ = 7.88 \times 10^{-4}L + \frac{P_{st}L}{0.75(29 \times 10^6)} \end{aligned}$$

$$9.5 \times 10^{-4} - \frac{P_{br}}{1.5(12 \times 10^6)} = \frac{P_{st}}{0.75(29 \times 10^6)}$$

$$P_{st} = 20\,662.5 - 1.2083P_{br} \rightarrow \text{Equation (1)}$$

$$\Sigma F_H = 0$$

$$P_{br} = P_{st} \rightarrow \text{Equation (2)}$$

Equations (1) and (2)

$$P_{st} = 20\,662.5 - 1.2083P_{st}$$

$$P_{st} = 9356.74 \text{ lb}$$

$$P_{br} = 9356.74 \text{ lb}$$

$$\sigma = P/A$$

$$\sigma_{br} = \frac{9356.74}{1.5} = 6237.83 \text{ psi compressive stress}$$

$$\sigma_{st} = \frac{9356.74}{0.74} = 12\,475.66 \text{ psi tensile stress}$$

Problem 271

A rigid bar of negligible weight is supported as shown in Fig. P-271. If $W = 80 \text{ kN}$, compute the temperature change that will cause the stress in the steel rod to be 55 MPa . Assume the coefficients of linear expansion are $11.7 \mu\text{m}/(\text{m}\cdot^\circ\text{C})$ for steel and $18.9 \mu\text{m}/(\text{m}\cdot^\circ\text{C})$ for bronze.

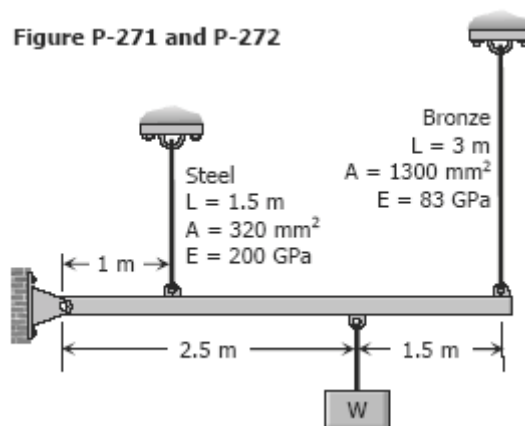

Solution 271

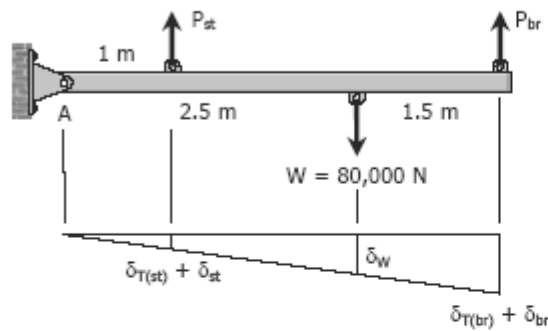

Stress in bronze when $\sigma_{st} = 55$ MPa

$$\Sigma M_A = 0$$

$$4P_{br} + P_{st} = 2.5(80000)$$

$$4\sigma_{br}(1300) + 55(320) = 2.5(80000)$$

$$\sigma_{br} = 35.08 \text{ MPa}$$

By ratio and proportion:

$$\frac{\delta_{T(st)} + \delta_{st}}{1} = \frac{\delta_{T(br)} + \delta_{br}}{4}$$

$$\delta_{T(st)} + \delta_{st} = 0.25[\delta_{T(br)} + \delta_{br}]$$

$$\begin{aligned} (\alpha L \Delta T)_{st} + \left(\frac{\sigma L}{E}\right)_{st} \\ = 0.25 \left[(\alpha L \Delta T)_{br} + \left(\frac{\sigma L}{E}\right)_{br} \right] \end{aligned}$$

$$(11.7 \times 10^{-6})(1500) \Delta T + \frac{55(1500)}{2000}$$

$$= 0.25 \left[(18.9 \times 10^{-6})(3000) \Delta T + \frac{35.08(3000)}{83000} \right]$$

$$0.01755 \Delta T + 0.4125 = 0.014175 \Delta T + 0.317$$

$$\Delta T = -28.3 \text{ }^\circ\text{C}$$

A temperature drop of 28.3 °C is needed to stress the steel to 55 MPa.

Problem 272

For the assembly in Fig. 271, find the stress in each rod if the temperature rises 30°C after a load $W = 120$ kN is applied.

Solution 272

$$\Sigma M_A = 0$$

$$4P_{br} + P_{st} = 2.5(80000)$$

$$4\sigma_{br}(1300) + \sigma_{st}(320) = 2.5(80000)$$

$$16.25\sigma_{br} + \sigma_{st} = 625$$

$$\sigma_{st} = 625 - 16.25\sigma_{br}$$

→ Equation (1)

$$\frac{\delta_{T(st)} + \delta_{st}}{1} = \frac{\delta_{T(br)} + \delta_{br}}{4}$$

$$\delta_{T(st)} + \delta_{st} = 0.25[\delta_{T(br)} + \delta_{br}]$$

$$\begin{aligned}
(\alpha L \Delta T)_{st} + \left(\frac{\sigma L}{E}\right)_{st} &= 0.25 \left[(\alpha L \Delta T)_{br} + \left(\frac{\sigma L}{E}\right)_{br} \right] \\
(11.7 \times 10^{-6})(1500)(30) + \frac{\sigma_{st}(1500)}{200000} &= 0.25 \left[(18.9 \times 10^{-6})(3000)(30) + \frac{\sigma_{br}(3000)}{83000} \right] \\
0.5265 + 0.0075\sigma_{st} &= 0.42525 + 0.00904\sigma_{br} \\
0.0075\sigma_{st} - 0.00904\sigma_{br} &= -0.10125 \\
0.0075(625 - 16.25\sigma_{br}) - 0.00904\sigma_{br} &= -0.10125 \\
4.6875 - 0.121875\sigma_{br} - 0.00904\sigma_{br} &= -0.10125 \\
4.78875 &= 0.130915\sigma_{br} \\
\sigma_{br} &= 36.58 \text{ }^\circ\text{C} \\
\sigma_{st} &= 625 - 16.25(36.58) \\
\sigma_{st} &= 30.58 \text{ }^\circ\text{C}
\end{aligned}$$

Problem 273

The composite bar shown in Fig. P-273 is firmly attached to unyielding supports. An axial force $P = 50$ kips is applied at 60°F . Compute the stress in each material at 120°F . Assume $\alpha = 6.5 \times 10^{-6}$ in/(in $\cdot^\circ\text{F}$) for steel and 12.8×10^{-6} in/(in $\cdot^\circ\text{F}$) for aluminum.

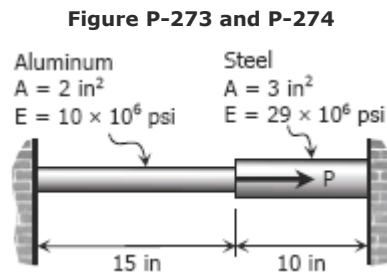

Solution 273

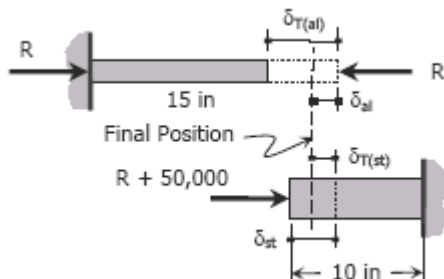

$$\begin{aligned}
\delta_{T(al)} &= (\alpha L \Delta T)_{al} \\
\delta_{T(al)} &= (12.8 \times 10^{-6})(15)(120 - 60) \\
\delta_{T(al)} &= 0.01152 \text{ inch} \\
\delta_{T(st)} &= (\alpha L \Delta T)_{st} \\
\delta_{T(st)} &= (6.5 \times 10^{-6})(10)(120 - 60) \\
\delta_{T(st)} &= 0.0039 \text{ inch}
\end{aligned}$$

$$\delta_{T(al)} - \delta_{al} = \delta_{st} - \delta_{T(st)}$$

$$0.011\ 52 - \left(\frac{PL}{AE}\right)_{al} = \left(\frac{PL}{AE}\right)_{st} - 0.0039$$

$$0.011\ 52 - \frac{R(15)}{2(10 \times 10^6)} = \frac{(R + 50\ 000)(10)}{3(29 \times 10^6)} - 0.0039$$

$$100\ 224 - 6.525R = R + 50\ 000 - 33\ 930$$

$$84\ 154 = 7.525R$$

$$R = 11\ 183.25\ \text{lbs}$$

$$P_{al} = R = 11\ 183.25\ \text{lbs}$$

$$P_{st} = R + 50\ 000 = 61\ 183.25\ \text{lbs}$$

$$\sigma = \frac{P}{A}$$

$$\sigma_{al} = \frac{11\ 183.25}{2}$$

$$= 5\ 591.62\ \text{psi}$$

$$\sigma_{st} = \frac{61\ 183.25}{3}$$

$$= 20\ 394.42\ \text{psi}$$

Problem 274

At what temperature will the aluminum and steel segments in Prob. 273 have numerically equal stress?

Solution 274

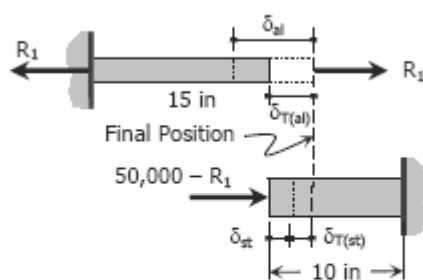

$$\sigma_{al} = \sigma_{st}$$

$$\frac{R_1}{2} = \frac{(50\ 000 - R_1)}{3}$$

$$3R_1 = 100\ 000 - 2R_1$$

$$R_1 = 20\ 000\ \text{lbs}$$

$$\delta = \frac{PL}{AE}$$

$$\delta_{al} = \frac{20\ 000(15)}{2(10 \times 10^6)} = 0.015\ \text{inch}$$

$$\delta_{st} = \frac{(50\ 000 - 20\ 000)(10)}{3(29 \times 10^6)} = 0.003\ 45\ \text{inch}$$

$$\delta_{al} - \delta_{T(al)} = \delta_{st} + \delta_{T(st)}$$

$$0.015 - (12.8 \times 10^{-6})(15) \Delta T = 0.003\ 45 + (6.5 \times 10^{-6})(10) \Delta T$$

$$0.011\ 55 = 0.000\ 257 \Delta T$$

$$\Delta T = 44.94^\circ\text{F}$$

A drop of 44.94°F from the standard temperature will make the aluminum and steel segments equal in stress.

Problem 275

A rigid horizontal bar of negligible mass is connected to two rods as shown in Fig. P-275. If the system is initially stress-free. Calculate the temperature change that will cause a tensile stress of 90 MPa in the brass rod. Assume that both rods are subjected to the change in temperature.

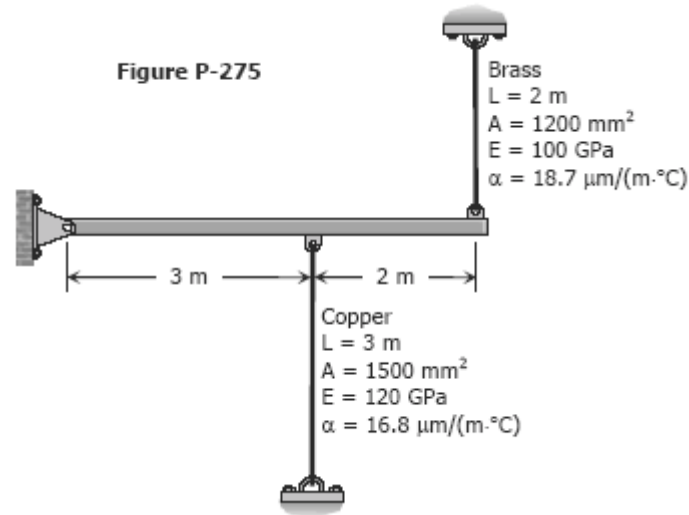

Solution 275

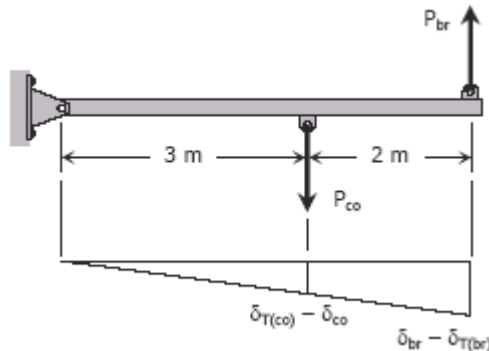

$$\begin{aligned}\Sigma M_{\text{hinge support}} &= 0 \\ 5P_{br} - 3P_{co} &= 0 \\ 5\sigma_{br} A_{br} - 3\sigma_{co} A_{co} &= 0 \\ 5(90)(1200) - 3\sigma_{co}(1500) &= 0 \\ \sigma_{co} &= 120 \text{ MPa}\end{aligned}$$

$$\begin{aligned}\delta &= \sigma L / E \\ \delta_{br} &= 90(2000) / 100\,000 = 1.8 \text{ mm} \\ \delta_{co} &= 120(3000) / 120\,000 = 3 \text{ mm}\end{aligned}$$

$$\frac{\delta_{T(co)} - \delta_{co}}{3} = \frac{\delta_{br} - \delta_{T(br)}}{5}$$

$$\begin{aligned}5\delta_{T(co)} - 5\delta_{co} &= 3\delta_{br} - 3\delta_{T(br)} \\ 5(16.8 \times 10^{-6})(3000) \Delta T - 5(3) &= 3(1.8) - 3(18.7 \times 10^{-6})(2000) \Delta T \\ 0.3642 \Delta T &= 20.4 \\ \Delta T &= 56.01^\circ\text{C drop in temperature}\end{aligned}$$

Problem 276

Four steel bars jointly support a mass of 15 Mg as shown in Fig. P-276. Each bar has a cross-sectional area of 600 mm². Find the load carried by each bar after a temperature rise of 50°C. Assume $\alpha = 11.7 \mu\text{m}/(\text{m}\cdot^\circ\text{C})$ and $E = 200 \text{ GPa}$.

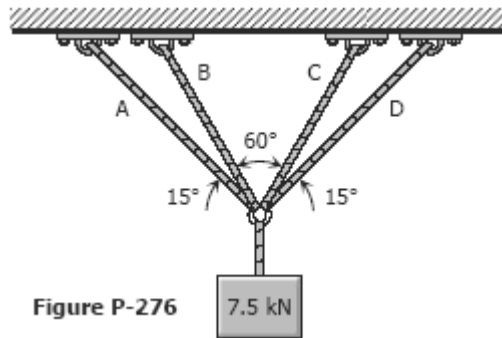
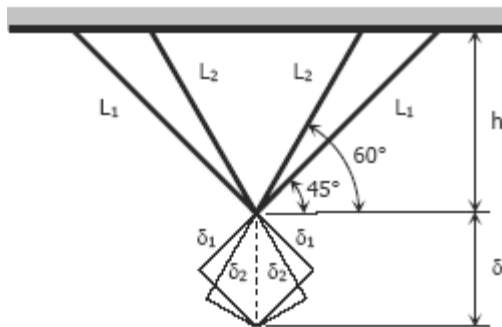

Figure P-276

Solution 276



$$h = L_1 \sin 45^\circ$$

$$h = L_2 \sin 60^\circ$$

$$h = h$$

$$L_1 \sin 45^\circ = L_2 \sin 60^\circ$$

$$L_1 = 1.2247L_2$$

$$\delta_1 = \delta \sin 45^\circ$$

$$\delta_2 = \delta \sin 60^\circ$$

$$\frac{\delta_1}{\delta_2} = \frac{\delta \sin 45^\circ}{\delta \sin 60^\circ}$$

$$\delta_1 = 0.8165\delta_2$$

$$\alpha L_1 \Delta T + \frac{P_1 L_1}{AE} = 0.8165 \left[\alpha L_2 \Delta T + \frac{P_2 L_2}{AE} \right]$$

$$(11.7 \times 10^{-6})L_1 (50) + \frac{P_1 L_1}{600(200000)}$$

$$= 0.8165 \left[(11.7 \times 10^{-6})L_2 (50) + \frac{P_2 L_2}{600(200000)} \right]$$

$$70,200L_1 + P_1 L_1 = 0.8165(70,200L_2 + P_2 L_2)$$

$$(70,200 + P_1)L_1 = 0.8165(70,200 + P_2)L_2$$

$$(70,200 + P_1)1.2247L_1 = 0.8165(70,200 + P_2)L_2$$

$$1.5(70,200 + P_1) = 70,200 + P_2$$

$$P_2 = 1.5P_1 + 35,100 \quad \rightarrow \text{Equation (1)}$$

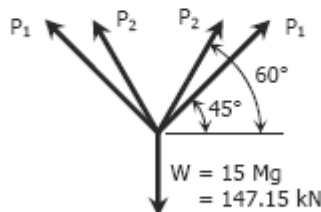

$$\Sigma F_V = 0$$

$$2(P_1 \sin 45^\circ) + 2(P_2 \sin 60^\circ) = 147.15(1000)$$

$$P_1 \sin 45^\circ + P_2 \sin 60^\circ = 72,575$$

$$P_1 \sin 45^\circ + (1.5P_1 + 35,100) \sin 60^\circ = 72,575$$

$$0.7071P_1 + 1.299P_1 + 30,397.49 = 72,575$$

$$2.0061P_1 = 42,177.51$$

$$P_1 = 21,024.63 \text{ N}$$

$$P_2 = 1.5(21,024.63) + 35,100$$

$$P_2 = 66,636.94 \text{ N}$$

$$P_A = P_D = P_1 = 21.02 \text{ kN}$$

$$P_B = P_C = P_2 = 66.64 \text{ kN}$$

Torsion

Consider a bar to be rigidly attached at one end and twisted at the other end by a torque or twisting moment T equivalent to $F \times d$, which is applied perpendicular to the axis of the bar, as shown in the figure. Such a bar is said to be in torsion.

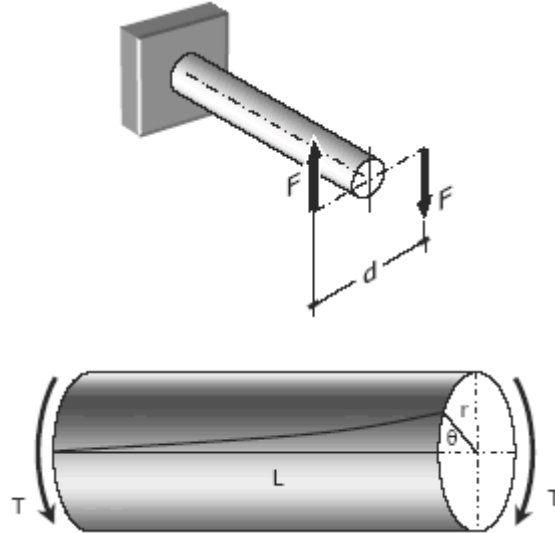

TORSIONAL SHEARING STRESS, τ

For a solid or hollow circular shaft subject to a twisting moment T , the torsional shearing stress τ at a distance ρ from the center of the shaft is

$$\tau = \frac{T\rho}{J} \text{ and } \tau_{\max} = \frac{Tr}{J}$$

where J is the polar moment of inertia of the section and r is the outer radius.

For solid cylindrical shaft:

$$J = \frac{\pi}{32} D^4$$

$$\tau_{\max} = \frac{16T}{\pi D^3}$$

For hollow cylindrical shaft:

$$J = \frac{\pi}{32} (D^4 - d^4)$$

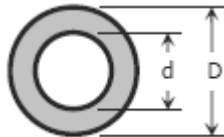
$$\tau_{\max} = \frac{16TD}{\pi(D^4 - d^4)}$$

ANGLE OF TWIST

The angle θ through which the bar length L will twist is

$$\theta = \frac{TL}{JG} \text{ in radians}$$

where T is the torque in N·mm, L is the length of shaft in mm, G is shear modulus in MPa, J is the polar moment of inertia in mm⁴, D and d are diameter in mm, and r is the radius in mm.

POWER TRANSMITTED BY THE SHAFT

A shaft rotating with a constant angular velocity ω (in radians per second) is being acted by a twisting moment T . The power transmitted by the shaft is

$$P = T\omega = 2\pi T f$$

where T is the torque in N·m, f is the number of revolutions per second, and P is the power in watts.

Solved Problems in Torsion

Problem 304

A steel shaft 3 ft long that has a diameter of 4 in. is subjected to a torque of 15 kip·ft. Determine the maximum shearing stress and the angle of twist. Use $G = 12 \times 10^6$ psi.

Solution 304

$$\tau_{\max} = \frac{16T}{\pi D^3} = \frac{16(15)(1000)(12)}{\pi(4^3)}$$

$$\tau_{\max} = 14\,324 \text{ psi}$$

$$\tau_{\max} = 14.3 \text{ ksi}$$

$$\theta = \frac{TL}{JG} = \frac{15(3)(1000)(12^2)}{\frac{1}{32}\pi(4^4)(12 \times 10^6)}$$

$$\theta = 0.0215 \text{ rad}$$

$$\theta = 1.23^\circ$$

Problem 305

What is the minimum diameter of a solid steel shaft that will not twist through more than 3° in a 6-m length when subjected to a torque of 12 kN·m? What maximum shearing stress is developed? Use $G = 83$ GPa.

Solution 305

$$\theta = \frac{TL}{JG}$$

$$3^\circ \left(\frac{\pi}{180^\circ} \right) = \frac{12(6)(1000^3)}{\frac{1}{32} \pi d^4 (83000)}$$

$$d = 113.98 \text{ mm}$$

$$\tau_{\max} = \frac{16T}{\pi d^3} = \frac{16(12)(1000^2)}{\pi(113.98^3)}$$

$$\tau_{\max} = 41.27 \text{ MPa}$$

Problem 306

A steel marine propeller shaft 14 in. in diameter and 18 ft long is used to transmit 5000 hp at 189 rpm. If $G = 12 \times 10^6$ psi, determine the maximum shearing stress.

Solution 306

$$T = \frac{P}{2\pi f} = \frac{5000(396000)}{2\pi(189)}$$

$$T = 1\,667\,337.5 \text{ lb}\cdot\text{in}$$

$$\tau_{\max} = \frac{16T}{\pi d^3} = \frac{16(1\,667\,337.5)}{\pi(14^3)}$$

$$\tau_{\max} = 3094.6 \text{ psi}$$

Problem 307

A solid steel shaft 5 m long is stressed at 80 MPa when twisted through 4° . Using $G = 83$ GPa, compute the shaft diameter. What power can be transmitted by the shaft at 20 Hz?

Solution 307

$$\theta = \frac{TL}{JG}$$

$$4^\circ \left(\frac{\pi}{180^\circ} \right) = \frac{T(5)(1000)}{\frac{1}{32} \pi d^4 (83000)}$$

$$T = 0.1138d^4$$

$$\tau_{\max} = \frac{16T}{\pi d^3}$$

$$80 = \frac{16(0.1138d^4)}{\pi d^3}$$

$$d = 138 \text{ mm}$$

$$T = \frac{P}{2\pi f}$$

$$0.1138d^4 = \frac{P}{2\pi(20)}$$

$$P = 14.3d^4 = 14.3(138^4)$$

$$P = 5\,186\,237\,285 \text{ N}\cdot\text{mm}/\text{sec}$$

$$P = 5\,186\,237.28 \text{ W}$$

$$P = 5.19 \text{ MW}$$

Problem 308

A 2-in-diameter steel shaft rotates at 240 rpm. If the shearing stress is limited to 12 ksi, determine the maximum horsepower that can be transmitted.

Solution 308

$$\tau_{\max} = \frac{16T}{\pi d^3}$$

$$12(1000) = \frac{16T}{\pi(2^3)}$$

$$T = 18\,849.56 \text{ lb}\cdot\text{in}$$

$$T = \frac{P}{2\pi f}$$

$$18\,849.56 = \frac{P(396000)}{2\pi(240)}$$

$$P = 71.78 \text{ hp}$$

Problem 309

A steel propeller shaft is to transmit 4.5 MW at 3 Hz without exceeding a shearing stress of 50 MPa or twisting through more than 1° in a length of 26 diameters. Compute the proper diameter if $G = 83$ GPa.

Solution 309

$$T = \frac{P}{2\pi f} = \frac{4.5(1000000)}{2\pi(3)}$$

$$T = 238\,732.41 \text{ N}\cdot\text{m}$$

Based on maximum allowable shearing stress:

$$\tau_{\max} = \frac{16T}{\pi d^3}$$

$$50 = \frac{16(238732.41)(1000)}{\pi d^3}$$

$$d = 289.71 \text{ mm}$$

Based on maximum allowable angle of twist:

$$\theta = \frac{TL}{JG}$$

$$1^\circ \left(\frac{\pi}{180^\circ} \right) = \frac{238732.41(26d)(1000)}{\frac{1}{32}\pi d^4(83000)}$$

$$d = 352.08 \text{ mm}$$

Use the bigger diameter, $d = 352 \text{ mm}$

Problem 310

Show that the hollow circular shaft whose inner diameter is half the outer diameter has a torsional strength equal to 15/16 of that of a solid shaft of the same outside diameter.

Solution 310

Hollow circular shaft:

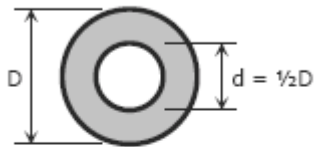

$$\begin{aligned}\tau_{\max\text{-hollow}} &= \frac{16TD}{\pi(D^4 - d^4)} \\ &= \frac{16TD}{\pi[D^4 - (\frac{1}{2}D)^4]} \\ &= \frac{16TD}{\pi(\frac{15}{16}D^4)} \\ &= \frac{16^2 T}{15\pi D^3}\end{aligned}$$

Solid circular shaft:

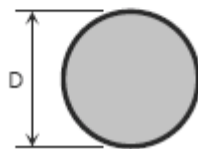

$$\begin{aligned}\tau_{\max\text{-solid}} &= \frac{16T}{\pi D^3} \\ &= \frac{15}{16} \left[\frac{16^2 T}{15\pi D^3} \right] \\ &= \frac{15}{16} \times \tau_{\max\text{-hollow}} \quad \text{ok!}\end{aligned}$$

Problem 311

An aluminum shaft with a constant diameter of 50 mm is loaded by torques applied to gears attached to it as shown in Fig. P-311. Using $G = 28$ GPa, determine the relative angle of twist of gear D relative to gear A.

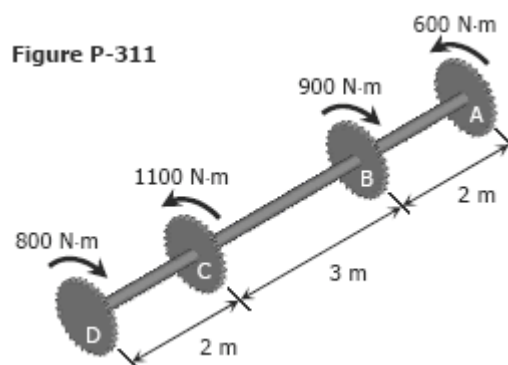

Solution 311

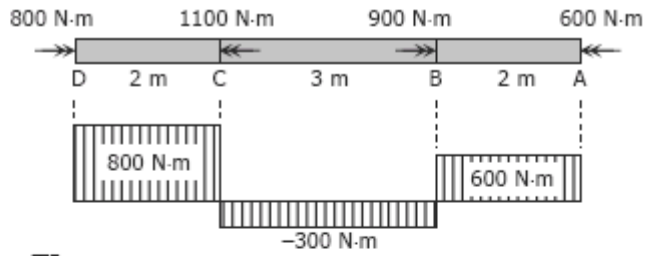

$$\theta = \frac{TL}{JG}$$

Rotation of D relative to A :

$$\theta_{D/A} = \frac{1}{JG} \sum TL$$

$$\theta_{D/A} = \frac{1}{\frac{1}{32}\pi(50^4)(28000)} [800(2) - 300(3) + 600(2)] (100^2)$$

$$\theta_{D/A} = 0.1106 \text{ rad}$$

$$\theta_{D/A} = 6.34^\circ$$

Problem 312

A flexible shaft consists of a 0.20-in-diameter steel wire encased in a stationary tube that fits closely enough to impose a frictional torque of 0.50 lb·in/in. Determine the maximum length of the shaft if the shearing stress is not to exceed 20 ksi. What will be the angular deformation of one end relative to the other end? $G = 12 \times 10^6$ psi.

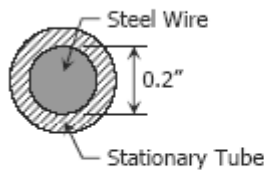

$$\tau_{\max} = \frac{16T}{\pi d^3}$$

$$20(1000) = \frac{16T}{\pi(0.20)^3}$$

$$T = 10\pi \text{ lb}\cdot\text{in}$$

$$L = \frac{T}{0.50 \text{ lb}\cdot\text{in}/\text{in}} = \frac{10\pi \text{ lb}\cdot\text{in}}{0.50 \text{ lb}\cdot\text{in}/\text{in}}$$

$$L = 20\pi \text{ in} = 62.83 \text{ in}$$

$$\theta = \frac{TL}{JG}$$

If $\theta = d\theta$, $T = 0.5L$ and $L = dL$

$$\int d\theta = \frac{1}{JG} \int_0^{20\pi} (0.5L)dL$$

$$\theta = \frac{1}{JG} \left[\frac{0.5L^2}{2} \right]_0^{20\pi} = \frac{1}{JG} [0.25(20\pi)^2 - 0.25(0)^2]$$

$$\theta = \frac{100\pi^2}{\frac{1}{32}\pi(0.20^4)(12 \times 10^6)}$$

$$\theta = 0.5234 \text{ rad} = 30^\circ$$

Problem 313

Determine the maximum torque that can be applied to a hollow circular steel shaft of 100-mm outside diameter and an 80-mm inside diameter without exceeding a shearing stress of 60 MPa or a twist of 0.5 deg/m. Use $G = 83 \text{ GPa}$.

Solution 313

Based on maximum allowable shearing stress:

$$\tau_{\max} = \frac{16TD}{\pi(D^4 - d^4)}$$

$$60 = \frac{16T(100)}{\pi(100^4 - 80^4)}$$

$$T = 6\,955\,486.14 \text{ N}\cdot\text{mm}$$

$$T = 6\,955.5 \text{ N}\cdot\text{m}$$

Based on maximum allowable angle of twist:

$$\theta = \frac{TL}{JG}$$

$$0.5^\circ \left(\frac{\pi}{180^\circ} \right) = \frac{T(1000)}{\frac{1}{32} \pi (100^4 - 80^4) (83\,000)}$$

$$T = 4\,198\,282.97 \text{ N}\cdot\text{mm}$$

$$T = 4\,198.28 \text{ N}\cdot\text{m}$$

Use the smaller torque, $T = 4\,198.28 \text{ N}\cdot\text{m}$

Problem 314

The steel shaft shown in Fig. P-314 rotates at 4 Hz with 35 kW taken off at A, 20 kW removed at B, and 55 kW applied at C. Using $G = 83 \text{ GPa}$, find the maximum shearing stress and the angle of rotation of gear A relative to gear C.

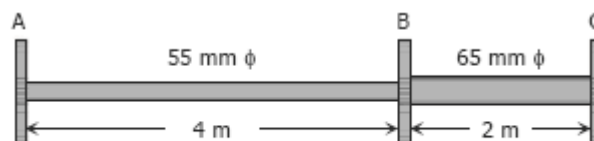

Figure P-314

Solution 314

$$T = \frac{P}{2\pi f}$$

$$T_A = \frac{-35(1000)}{2\pi(4)} = -1392.6 \text{ N}\cdot\text{m}$$

$$T_B = \frac{-20(1000)}{2\pi(4)} = -795.8 \text{ N}\cdot\text{m}$$

$$T_C = \frac{55(1000)}{2\pi(4)} = 2188.4 \text{ N}\cdot\text{m}$$

Relative to C:

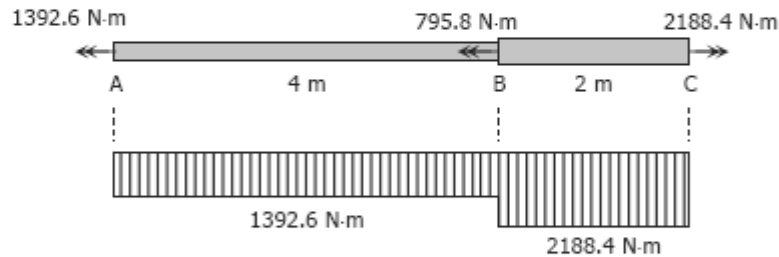

$$\tau_{\max} = \frac{16T}{\pi d^3}$$

$$\tau_{AB} = \frac{16(1392.6)(1000)}{\pi(55^3)} = 42.63 \text{ MPa}$$

$$\tau_{BC} = \frac{16(2188.4)(1000)}{\pi(65^3)} = 40.58 \text{ MPa}$$

$$\therefore \tau_{\max} = \tau_{AB} = 42.63 \text{ MPa}$$

$$\theta = \frac{TL}{JG}$$

$$\theta_{A/C} = \frac{1}{G} \sum \frac{TL}{J}$$

$$\theta_{A/C} = \frac{1}{83000} \left[\frac{1392.6(4)}{\frac{1}{32} \pi (55^4)} + \frac{2188.4(2)}{\frac{1}{32} \pi (65^4)} \right] (1000^2)$$

$$\theta_{A/C} = 0.104796585 \text{ rad}$$

$$\theta_{A/C} = 6.004^\circ$$

Problem 315

A 5-m steel shaft rotating at 2 Hz has 70 kW applied at a gear that is 2 m from the left end where 20 kW are removed. At the right end, 30 kW are removed and another 20 kW leaves the shaft at 1.5 m from the right end. (a) Find the uniform shaft diameter so that the shearing stress will not exceed 60 MPa. (b) If a uniform shaft diameter of 100 mm is specified, determine the angle by which one end of the shaft lags behind the other end. Use $G = 83 \text{ GPa}$.

Solution 315

$$T = \frac{P}{2\pi f}$$

$$T_A = T_C = \frac{-20(1000)}{2\pi(2)} = -1591.55 \text{ N}\cdot\text{m}$$

$$T_B = \frac{70(1000)}{2\pi(2)} = 5570.42 \text{ N}\cdot\text{m}$$

$$T_D = \frac{-30(1000)}{2\pi(2)} = -2387.32 \text{ N}\cdot\text{m}$$

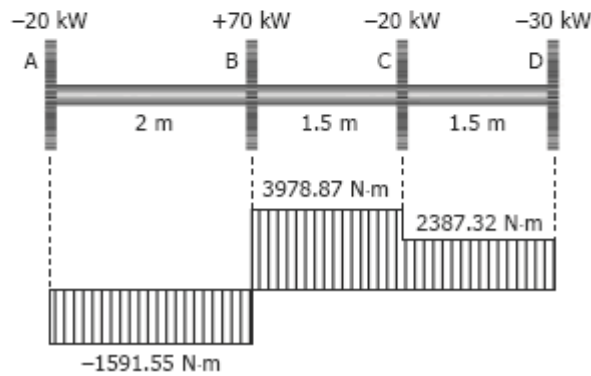

Part (a)

$$\tau_{\max} = \frac{16T}{\pi d^3}$$

$$\text{For AB: } 60 = \frac{16(1591.55)(1000)}{\pi d^3}$$

$$d = 51.3 \text{ mm}$$

$$\text{For BC: } 60 = \frac{16(3978.87)(1000)}{\pi d^3}$$

$$d = 69.6 \text{ mm}$$

$$\text{For CD: } 60 = \frac{16(2387.32)(1000)}{\pi d^3}$$

$$d = 58.7 \text{ mm}$$

Use $d = 69.6 \text{ mm}$

Part (b)

$$\theta = \frac{TL}{JG}$$

$$\theta_{D/A} = \frac{1}{JG} \sum TL$$

$$\theta_{D/A} = \frac{1}{\frac{1}{32}\pi(100^4)(83000)} [-1591.55(2) + 3978.87(1.5) + 2387.32(1.5)] (1000^2)$$

$$\theta_{D/A} = 0.007813 \text{ rad}$$

$$\theta_{D/A} = 0.448^\circ$$

Problem 316

A compound shaft consisting of a steel segment and an aluminum segment is acted upon by two torques as shown in Fig. P-316. Determine the maximum permissible value of T subject to the following conditions: $\tau_{st} = 83$ MPa, $\tau_{al} = 55$ MPa, and the angle of rotation of the free end is limited to 6° . For steel, $G = 83$ GPa and for aluminum, $G = 28$ GPa.

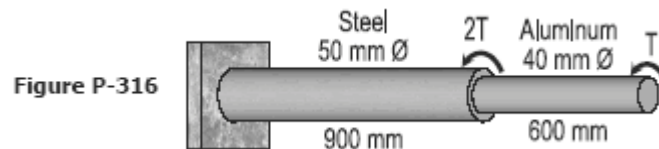

Solution 316

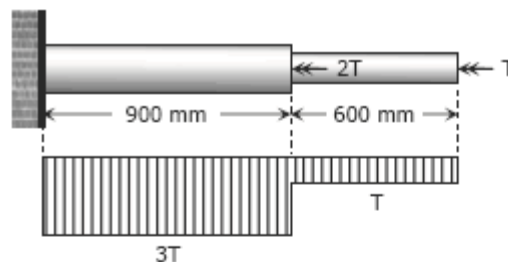

Based on maximum shearing stress $\tau_{\max} = 16T / \pi d^3$:

$$\tau_{st} = \frac{16(3T)}{\pi(50^3)} = 83$$

$$T = 679\,042.16 \text{ N}\cdot\text{mm}$$

$$T = 679.04 \text{ N}\cdot\text{m}$$

$$\tau_{al} = \frac{16T}{\pi(40^3)} = 55$$

$$T = 691\,150.38 \text{ N}\cdot\text{mm}$$

$$T = 691.15 \text{ N}\cdot\text{m}$$

Based on maximum angle of twist:

$$\theta = \left(\frac{TL}{JG} \right)_{st} + \left(\frac{TL}{JG} \right)_{al}$$

$$6^\circ \left(\frac{\pi}{180^\circ} \right) = \frac{3T(900)}{\frac{1}{32} \pi (50^4) (83\,000)} + \frac{T(600)}{\frac{1}{32} \pi (40^4) (28\,000)}$$

$$T = 757\,316.32 \text{ N}\cdot\text{mm}$$

$$T = 757.32 \text{ N}\cdot\text{m}$$

Use $T = 679.04 \text{ N}\cdot\text{m}$

Problem 317

A hollow bronze shaft of 3 in. outer diameter and 2 in. inner diameter is slipped over a solid steel shaft 2 in. in diameter and of the same length as the hollow shaft. The two shafts are then fastened rigidly together at their ends. For bronze, $G = 6 \times 10^6$ psi, and for steel, $G = 12 \times 10^6$ psi. What torque can be applied to the composite shaft without exceeding a shearing stress of 8000 psi in the bronze or 12 ksi in the steel?

Solution 317

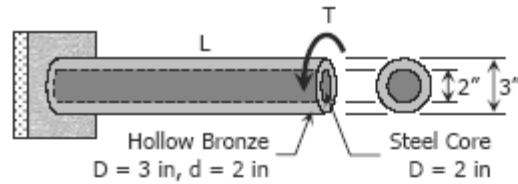

$$\theta_{st} = \theta_{br}$$

$$\left(\frac{TL}{JG}\right)_{st} = \left(\frac{TL}{JG}\right)_{br}$$

$$\frac{T_{st}L}{\frac{1}{32}\pi(2^4)(12 \times 10^6)} = \frac{T_{br}L}{\frac{1}{32}\pi(3^4 - 2^4)(6 \times 10^6)}$$

$$\frac{T_{st}}{192 \times 10^6} = \frac{T_{br}}{390 \times 10^6} \quad \rightarrow \text{Equation (1)}$$

Applied Torque = Resisting Torque

$$T = T_{st} + T_{br} \quad \rightarrow \text{Equation (2)}$$

Equation (1) with T_{st} in terms of T_{br} and Equation (2)

$$T = \frac{192 \times 10^6}{390 \times 10^6} T_{br} + T_{br}$$

$$T_{br} = 0.6701T$$

Equation (1) with T_{br} in terms of T_{st} and Equation (2)

$$T = T_{st} + \frac{390 \times 10^6}{192 \times 10^6} T_{st}$$

$$T_{st} = 0.3299T$$

Based on hollow bronze ($T_{br} = 0.6701T$)

$$\tau_{\max} = \left[\frac{16TD}{\pi(D^4 - d^4)} \right]_{br}$$

$$8000 = \frac{16(0.6701T)(3)}{\pi(3^4 - 2^4)}$$

$$T = 50\,789.32 \text{ lb-in}$$

$$T = 4232.44 \text{ lb-ft}$$

Based on steel core ($T_{st} = 0.3299T$):

$$\tau_{\max} = \left[\frac{16T}{\pi D^3} \right]_{st}$$

$$12\,000 = \frac{16(0.3299T)}{\pi(2^3)}$$

$$T = 57\,137.18 \text{ lb-in}$$

$$T = 4761.43 \text{ lb-ft}$$

Use $T = 4232.44 \text{ lb-ft}$

Problem 318

A solid aluminum shaft 2 in. in diameter is subjected to two torques as shown in Fig. P-318. Determine the maximum shearing stress in each segment and the angle of rotation of the free end. Use $G = 4 \times 10^6$ psi.

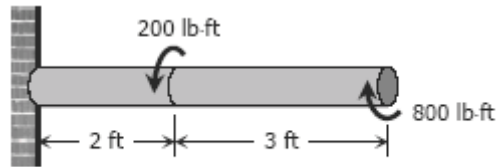
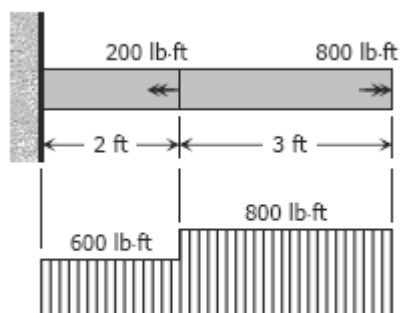

Figure P-318

Solution 318



$$\tau_{\max} = \frac{16T}{\pi D^3}$$

For 2-ft segment:

$$\tau_{\max 2} = \frac{16(600)(12)}{\pi(2^3)} = 4583.66 \text{ psi}$$

For 3-ft segment:

$$\tau_{\max 3} = \frac{16(800)(12)}{\pi(2^3)} = 6111.55 \text{ psi}$$

$$\theta = \frac{TL}{JG}$$

$$\theta = \frac{1}{JG} \sum TL$$

$$\theta = \frac{1}{\frac{1}{32}\pi(2^4)(4 \times 10^6)} [600(2) + 800(3)] (12^2)$$

$$\theta = 0.0825 \text{ rad}$$

$$\theta = 4.73^\circ$$

Problem 319

The compound shaft shown in Fig. P-319 is attached to rigid supports. For the bronze segment AB, the diameter is 75 mm, $\tau \leq 60$ MPa, and $G = 35$ GPa. For the steel segment BC, the diameter is 50 mm, $\tau \leq 80$ MPa, and $G = 83$ GPa. If $a = 2$ m and $b = 1.5$ m, compute the maximum torque T that can be applied.

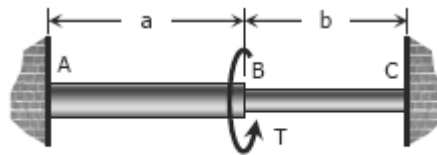
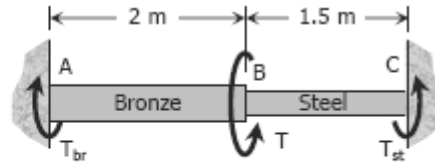

Figure P-319 and P-320

Solution 319



$$\Sigma M = 0$$

$$T = T_{br} + T_{st} \quad \rightarrow \text{Equation (1)}$$

$$\theta_{br} = \theta_{st}$$

$$\left(\frac{TL}{JG} \right)_{br} = \left(\frac{TL}{JG} \right)_{st}$$

$$\frac{T_{br}(2)(1000)}{\frac{1}{32}\pi(75^4)(35000)} = \frac{T_{st}(1.5)(1000)}{\frac{1}{32}\pi(50^4)(83000)}$$

$$\left. \begin{aligned} T_{br} &= 1.6011T_{st} \\ T_{st} &= 0.6246T_{br} \end{aligned} \right\} \text{Equations (2)}$$

$$\tau_{\max} = \frac{16T}{\pi D^3}$$

Based on $\tau_{br} \leq 60 \text{ MPa}$

$$60 = \frac{16T_{br}}{\pi(75^3)}$$

$$T_{br} = 4\,970\,097.75 \text{ N}\cdot\text{mm}$$

$$T_{br} = 4.970 \text{ kN}\cdot\text{m} \rightarrow \text{Maximum allowable torque for bronze}$$

$$T_{st} = 0.6246(4.970) \quad \rightarrow \text{From one of Equations (2)}$$

$$T_{st} = 3.104 \text{ kN}\cdot\text{m}$$

Based on $\tau_{st} \leq 80 \text{ MPa}$

$$80 = \frac{16T_{st}}{\pi(50^3)}$$

$$T_{st} = 1\,963\,495.41 \text{ N}\cdot\text{mm}$$

$$T_{st} = 1.963 \text{ kN}\cdot\text{m} \rightarrow \text{maximum allowable torque for steel}$$

$$T_{br} = 1.6011(1.963) \quad \rightarrow \text{From Equations (2)}$$

$$T_{br} = 3.142 \text{ kN}\cdot\text{m}$$

Use $T_{br} = 3.142 \text{ kN}\cdot\text{m}$ and $T_{st} = 1.963 \text{ kN}\cdot\text{m}$

$$T = 3.142 + 1.963 \quad \rightarrow \text{From Equation (1)}$$

$$T = 5.105 \text{ kN}\cdot\text{m}$$

Problem 320

In Prob. 319, determine the ratio of lengths b/a so that each material will be stressed to its permissible limit. What torque T is required?

Solution 320

From Solution 319:

$$\text{Maximum } T_{br} = 4.970 \text{ kN}\cdot\text{m}$$

$$\text{Maximum } T_{st} = 1.963 \text{ kN}\cdot\text{m}$$

$$\theta_{br} = \theta_{st}$$

$$\left(\frac{TL}{JG}\right)_{br} = \left(\frac{TL}{JG}\right)_{st}$$

$$\frac{4.973a (1000^2)}{\frac{1}{32} \pi (75^4) (35\,000)} = \frac{1.963b (1000^2)}{\frac{1}{32} \pi (50^4) (83\,000)}$$

$$b/a = 1.187$$

$$T = \max T_{br} + \max T_{st}$$

$$T = 4.970 + 1.963$$

$$T = 6.933 \text{ kN}\cdot\text{m}$$

Problem 321

A torque T is applied, as shown in Fig. P-321, to a solid shaft with built-in ends. Prove that the resisting torques at the walls are $T_1 = Tb/L$ and $T_2 = Ta/L$. How would these values be changed if the shaft were hollow?

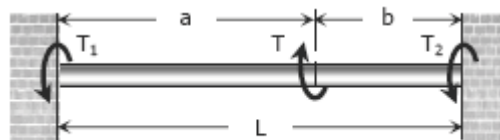

Figure P-321

Solution 321

$$\Sigma M = 0$$

$$T = T_1 + T_2 \quad \rightarrow \text{Equation (1)}$$

$$\theta_1 = \theta_2$$

$$\left(\frac{TL}{JG}\right)_1 = \left(\frac{TL}{JG}\right)_2$$

$$\frac{T_1 a}{JG} = \frac{T_2 b}{JG}$$

$$\left. \begin{aligned} T_1 &= \frac{b}{a} T_2 \\ T_2 &= \frac{a}{b} T_1 \end{aligned} \right\} \text{Equations (2)}$$

Equations (1) and (2) with T_2 in terms of T_1 :

$$T = T_1 + \frac{a}{b} T_1$$

$$T = \frac{T_1 b + T_1 a}{b}$$

$$T = \frac{(b+a)T_1}{b}$$

$$T = \frac{LT_1}{b}$$

$$T_1 = Tb/L$$

Equations (1) and (2) with T_1 in terms of T_2 :

$$T = \frac{b}{a} T_2 + T_2$$

$$T = \frac{T_2 b + T_2 a}{a}$$

$$T = \frac{(b+a)T_2}{a}$$

$$T = \frac{LT_2}{a}$$

$$T_2 = Ta/L$$

If the shaft were hollow, Equation (1) would be the same and the equality $\theta_1 = \theta_2$, by direct investigation, would yield the same result in Equations (2). Therefore, the values of T_1 and T_2 are the same (no change) if the shaft were hollow.

Problem 322

A solid steel shaft is loaded as shown in Fig. P-322. Using $G = 83 \text{ GPa}$, determine the required diameter of the shaft if the shearing stress is limited to 60 MPa and the angle of rotation at the free end is not to exceed 4 deg .

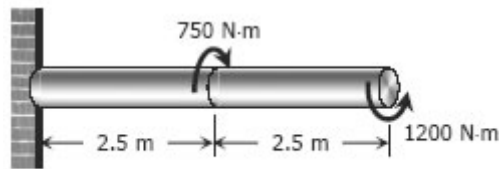

Figure P-322

Solution 322

Based on maximum allowable shear:

$$\tau_{\max} = \frac{16T}{\pi D^3}$$

For the 1st segment:

$$60 = \frac{450(2.5)(1000^2)}{\pi D^3}$$

$$D = 181.39 \text{ mm}$$

For the 2nd segment:

$$60 = \frac{1200(2.5)(1000^2)}{\pi D^3}$$

$$D = 251.54 \text{ mm}$$

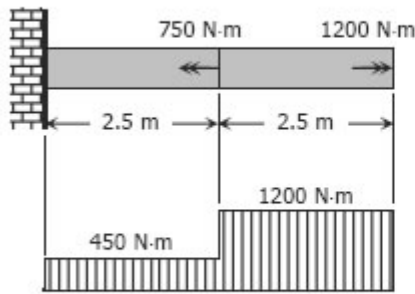

Based on maximum angle of twist:

$$\theta = \frac{TL}{JG}$$

$$\theta = \frac{1}{JG} \sum TL$$

$$4^\circ \left(\frac{\pi}{180^\circ} \right) = \frac{1}{\frac{1}{32} \pi D^4 (83000)} [450(2.5) + 1200(2.5)] (1000^2)$$

$$D = 51.89 \text{ mm}$$

Use $D = 251.54 \text{ mm}$

Problem 323

A shaft composed of segments AC, CD, and DB is fastened to rigid supports and loaded as shown in Fig. P-323. For bronze, $G = 35 \text{ GPa}$; aluminum, $G = 28 \text{ GPa}$, and for steel, $G = 83 \text{ GPa}$. Determine the maximum shearing stress developed in each segment.

Figure P-323

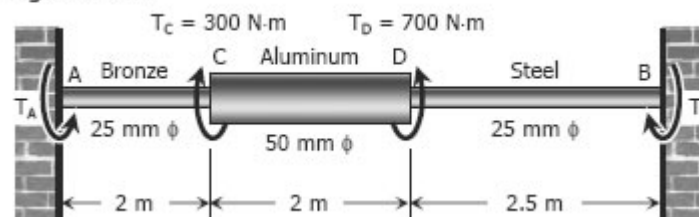

Solution 323

Stress developed in each segment with respect to T_A :

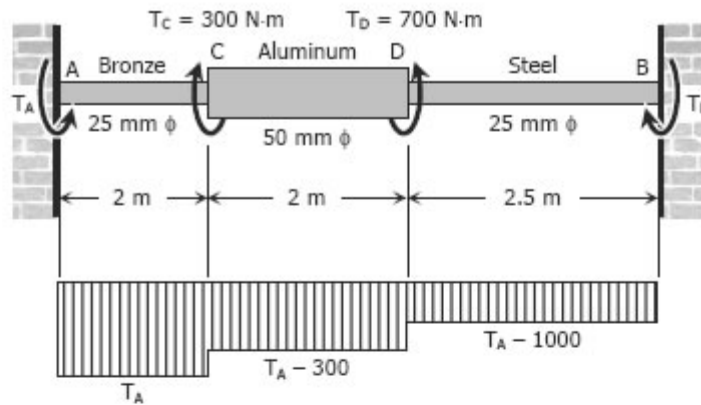

The rotation of B relative to A is zero.

$$\theta_{A/B} = 0$$

$$\left(\sum \frac{TL}{JG} \right)_{A/B} = 0$$

$$\frac{T_A(2)(1000^2)}{\frac{1}{32}\pi(25^4)(35000)} + \frac{(T_A - 300)(2)(1000^2)}{\frac{1}{32}\pi(50^4)(28000)} + \frac{(T_A - 1000)(2.5)(1000^2)}{\frac{1}{32}\pi(25^4)(83000)} = 0$$

$$\frac{2T_A}{(25^4)(35)} + \frac{2(T_A - 300)}{(50^4)(28)} + \frac{2.5(T_A - 1000)}{(25^4)(83)} = 0$$

$$\frac{16T_A}{35} + \frac{T_A - 300}{28} + \frac{20(T_A - 1000)}{83} = 0$$

$$\frac{16}{35}T_A + \frac{1}{28}T_A - \frac{75}{7} + \frac{20}{83}T_A - \frac{20000}{83} = 0$$

$$\frac{8527}{11620}T_A = 251.678$$

$$T_A = 342.97 \text{ N}\cdot\text{m}$$

$$\Sigma M = 0$$

$$T_A + T_B = 300 + 700$$

$$342.97 + T_B = 1000$$

$$T_B = 657.03 \text{ N}\cdot\text{m}$$

$$T_{br} = 342.97 \text{ N}\cdot\text{m}$$

$$T_{al} = 342.97 - 300 = 42.97 \text{ N}\cdot\text{m}$$

$$T_{st} = 342.97 - 1000 = -657.03 \text{ N}\cdot\text{m} = -T_B \text{ (ok!)}$$

$$\tau_{\max} = \frac{16T}{\pi D^3}$$

$$\tau_{br} = \frac{16(342.97)(1000)}{\pi(25^3)} = 111.79 \text{ MPa}$$

$$\tau_{al} = \frac{16(42.97)(1000)}{\pi(50^3)} = 1.75 \text{ MPa}$$

$$\tau_{st} = \frac{16(657.03)(1000)}{\pi(25^3)} = 214.16 \text{ MPa}$$

Problem 324

The compound shaft shown in Fig. P-324 is attached to rigid supports. For the bronze segment AB, the maximum shearing stress is limited to 8000 psi and for the steel segment BC, it is limited to 12 ksi. Determine the diameters of each segment so that each material will be simultaneously stressed to its permissible limit when a torque $T = 12 \text{ kip}\cdot\text{ft}$ is applied. For bronze, $G = 6 \times 10^6 \text{ psi}$ and for steel, $G = 12 \times 10^6$

psi.

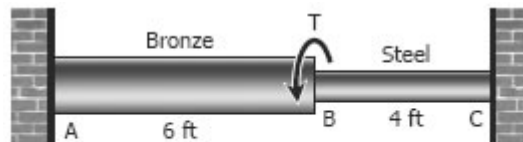

Figure P-324

Solution 324

$$\tau_{\max} = \frac{16T}{\pi D^3}$$

For bronze:

$$8000 = \frac{16T_{br}}{\pi D_{br}^3}$$

$$T_{br} = 500\pi D_{br}^3 \text{ lb}\cdot\text{in}$$

For steel:

$$12\,000 = \frac{16T_{st}}{\pi D_{st}^3}$$

$$T_{st} = 750\pi D_{st}^3 \text{ lb-in}$$

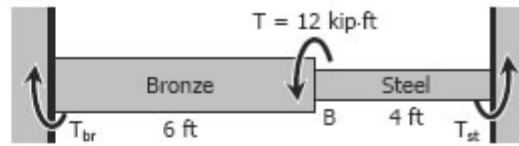

$$\Sigma M = 0$$

$$T_{br} + T_{st} = T$$

$$T_{br} + T_{st} = 12(1000)(12)$$

$$T_{br} + T_{st} = 144\,000 \text{ lb-in}$$

$$500\pi D_{br}^3 + 750\pi D_{st}^3 = 144\,000$$

$$D_{br}^3 = 288/\pi - 1.5 D_{st}^3 \rightarrow \text{equation (1)}$$

$$\theta_{br} = \theta_{st}$$

$$\left(\frac{TL}{JG}\right)_{br} = \left(\frac{TL}{JG}\right)_{st}$$

$$\frac{T_{br}(6)}{\frac{1}{32}\pi D_{br}^4(6 \times 10^6)} = \frac{T_{st}(4)}{\frac{1}{32}\pi D_{st}^4(12 \times 10^6)}$$

$$\frac{T_{br}}{D_{br}^4} = \frac{T_{st}}{3D_{st}^4}$$

$$\frac{500\pi D_{br}^3}{D_{br}^4} = \frac{750\pi D_{st}^3}{3D_{st}^4}$$

$$D_{st} = 0.5D_{br}$$

From Equation (1)

$$D_{br}^3 = 288/\pi - 1.5(0.5D_{br})^3$$

$$1.1875 D_{br}^3 = 288/\pi$$

$$D_{br} = 4.26 \text{ in.}$$

$$D_{st} = 0.5(4.26) = 2.13 \text{ in.}$$

Problem 325

The two steel shaft shown in Fig. P-325, each with one end built into a rigid support have flanges rigidly attached to their free ends. The shafts are to be bolted together at their flanges. However, initially there is a 6° mismatch in the location of the bolt holes as shown in the figure. Determine the maximum shearing stress in each shaft after the shafts are bolted together. Use $G = 12 \times 10^6$ psi and neglect deformations of the bolts and

flanges.

Solution 325

$$\theta_{\text{of } 6.5' \text{ shaft}} + \theta_{\text{of } 3.25' \text{ shaft}} = 6^\circ$$

$$\left(\frac{TL}{JG}\right)_{\text{of } 6.5' \text{ shaft}} + \left(\frac{TL}{JG}\right)_{\text{of } 3.25' \text{ shaft}} = 6^\circ \left(\frac{\pi}{180^\circ}\right)$$

$$\frac{T(6.5)(12^2)}{\frac{1}{32}\pi(2^4)(12 \times 10^6)} + \frac{T(3.25)(12^2)}{\frac{1}{32}\pi(1.5^4)(12 \times 10^6)} = \frac{\pi}{30}$$

$$T = 817.32 \text{ lb-ft}$$

$$\tau_{\text{max}} = \frac{16T}{\pi D^3}$$

$$\tau_{\text{of } 6.5' \text{ shaft}} = \frac{16(817.32)(12)}{\pi(2^3)} = 6243.86 \text{ psi}$$

$$\tau_{\text{of } 3.25' \text{ shaft}} = \frac{16(817.32)(12)}{\pi(1.5^3)} = 14\,800.27 \text{ psi}$$

Flanged Bolt Couplings

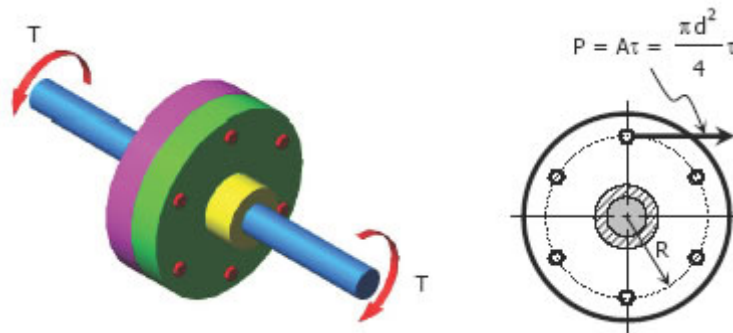

In shaft connection called flanged bolt couplings (see figure above), the torque is transmitted by the shearing force P created in the bolts that is assumed to be uniformly distributed. For any number of bolts n , the torque capacity of the coupling is

$$T = PRn = \frac{\pi d^2}{4} \tau Rn$$

If a coupling has two concentric rows of bolts, the torque capacity is

$$T = P_1 R_1 n_1 + P_2 R_2 n_2$$

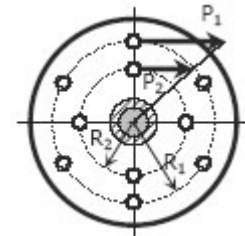

where the subscript 1 refers to bolts on the outer circle and subscript 2 refers to bolts on the inner circle. See figure.

For rigid flanges, the shear deformations in the bolts are proportional to their radial distances from the shaft axis. The shearing strains are related by

$$\frac{\gamma_1}{R_1} = \frac{\gamma_2}{R_2}$$

Using Hooke's law for shear, $G = \tau / \gamma$, we have

$$\frac{\tau_1}{G_1 R_1} = \frac{\tau_2}{G_2 R_2} \quad \text{or} \quad \frac{P_1 / A_1}{G_1 R_1} = \frac{P_2 / A_2}{G_2 R_2}$$

If the bolts on the two circles have the same area, $A_1 = A_2$, and if the bolts are made of the same material, $G_1 = G_2$, the relation between P_1 and P_2 reduces to

$$\frac{P_1}{R_1} = \frac{P_2}{R_2}$$

Solved Problems in Flanged Bolt Couplings

Problem 326

A flanged bolt coupling consists of ten 20-mm diameter bolts spaced evenly around a bolt circle 400 mm in diameter. Determine the torque capacity of the coupling if the allowable shearing stress in the bolts is 40 MPa.

Solution 326

$$T = PRn = A\tau Rn = \frac{1}{4} \pi d^2 \tau Rn$$

$$T = \frac{1}{4} \pi (20^2)(40)(200)(10)$$

$$T = 8\,000\,000\pi \text{ N}\cdot\text{mm}$$

$$T = 8\pi \text{ kN}\cdot\text{m} = 25.13 \text{ kN}\cdot\text{m}$$

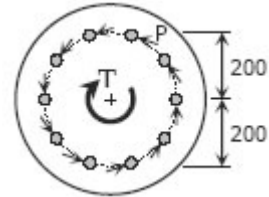

Problem 327

A flanged bolt coupling consists of ten steel 1/2-in.-diameter bolts spaced evenly around a bolt circle 14 in. in diameter. Determine the torque capacity of the coupling if the allowable shearing stress in the bolts is 6000 psi.

Solution 327

$$T = PRn = A\tau Rn = \frac{1}{4} \pi d^2 \tau Rn$$

$$T = \frac{1}{4} \pi (1/2)^2 (6000)(7)(10)$$

$$T = 26250\pi \text{ lb}\cdot\text{in}$$

$$T = 2187.5\pi \text{ lb}\cdot\text{ft} = 6872.23 \text{ lb}\cdot\text{ft}$$

Problem 328

A flanged bolt coupling consists of eight 10-mm diameter steel bolts on a bolt circle 400 mm in diameter, and six 10-mm-diameter steel bolts on a concentric bolt circle 300 mm in diameter, as shown in Fig. 3-7. What torque can be applied without exceeding a shearing stress of 60 MPa in the bolts?

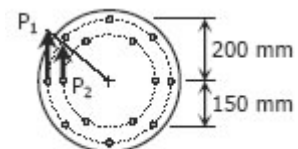

Figure 3-7

Solution 328

For one bolt in the outer circle:

$$P_1 = A\tau = \frac{\pi(10^2)}{4} (60)$$

$$P_1 = 1500\pi \text{ N}$$

For one bolt in the inner circle:

$$\frac{P_1}{R_1} = \frac{P_2}{R_2}$$

$$\frac{1500\pi}{200} = \frac{P_2}{150}$$

$$P_2 = 1125\pi \text{ N}$$

$$T = P_1R_1n_1 + P_2R_2n_2$$

$$T = 1500\pi(200)(8) + 1125\pi(150)(6)$$

$$T = 3\,412\,500\pi \text{ N}\cdot\text{mm}$$

$$T = 3.4125\pi \text{ kN}\cdot\text{m} = \mathbf{10.72 \text{ kN}\cdot\text{m}}$$

Problem 329

A torque of 700 lb-ft is to be carried by a flanged bolt coupling that consists of eight ½ -in.-diameter steel bolts on a circle of diameter 12 in. and six ½ -in.-diameter steel bolts on a circle of diameter 9 in. Determine the shearing stress in the bolts.

Solution 329

$$\frac{P_1}{R_1} = \frac{P_2}{R_2}$$

$$\frac{A\tau_1}{6} = \frac{A\tau_2}{4.5}$$

$$\tau_2 = 0.75\tau_1$$

$$T = P_1R_1n_1 + P_2R_2n_2$$

$$700(12) = \frac{1}{4}\pi(\frac{1}{2})^2\tau_1(6)(8) + \frac{1}{4}\pi(\frac{1}{2})^2\tau_2(4.5)(6)$$

$$8400 = 3\pi\tau_1 + 1.6875\pi(0.75\tau_1)$$

$$8400 = 13.4\tau_1$$

$$\tau_1 = \mathbf{626.87 \text{ psi}} \rightarrow \text{bolts in the outer circle}$$

$$\tau_2 = 0.75(626.87) = \mathbf{470.15 \text{ psi}} \rightarrow \text{bolts in the inner circle}$$

Problem 330

Determine the number of 10-mm-diameter steel bolts that must be used on the 400-mm bolt circle of the coupling described in Prob. 328 to increase the torque capacity to 14 kN·m

Solution 330

$$T = P_1 R_1 n_1 + P_2 R_2 n_2$$

$$14(1000^2) = 1500\pi(200)n_1 + 1125\pi(150)(6)$$

$$n_1 = 11.48 \text{ say } 12 \text{ bolts}$$

Problem 331

A flanged bolt coupling consists of six $\frac{1}{2}$ -in. steel bolts evenly spaced around a bolt circle 12 in. in diameter, and four $\frac{3}{4}$ -in. aluminum bolts on a concentric bolt circle 8 in. in diameter. What torque can be applied without exceeding 9000 psi in the steel or 6000 psi in the aluminum? Assume $G_{st} = 12 \times 10^6$ psi and $G_{al} = 4 \times 10^6$ psi.

Solution 331

$$T = (PRn)_{st} + (PRn)_{al}$$

$$T = (A\tau Rn)_{st} + (A\tau Rn)_{al}$$

$$T = \frac{1}{4}\pi(\frac{1}{2})^2\tau_{st}(6)(6) + \frac{1}{4}\pi(\frac{3}{4})^2\tau_{al}(4)(4)$$

$$T = 2.25\pi\tau_{st} + 2.25\pi\tau_{al}$$

$$T = 2.25\pi(\tau_{st} + \tau_{al}) \quad \rightarrow \text{Equation (1)}$$

$$\left(\frac{\tau}{GR}\right)_{st} = \left(\frac{\tau}{GR}\right)_{al}$$

$$\frac{\tau_{st}}{(12 \times 10^6)(6)} = \frac{\tau_{al}}{(4 \times 10^6)(4)}$$

$$\tau_{st} = \frac{9}{2}\tau_{al} \quad \rightarrow \text{Equation (2a)}$$

$$\tau_{al} = \frac{2}{9}\tau_{st} \quad \rightarrow \text{Equation (2b)}$$

Equations (1) and (2a)

$$T = 2.25\pi\left(\frac{9}{2}\tau_{al} + \tau_{al}\right) = 12.375\pi\tau_{al}$$

$$T = 12.375\pi(6000) = 74\,250\pi \text{ lb-in}$$

$$T = 233.26 \text{ kip-in}$$

Equations (1) and (2b)

$$T = 2.25\pi\left(\tau_{st} + \frac{2}{9}\tau_{st}\right) = 2.75\pi\tau_{st}$$

$$T = 2.25\pi(9000) = 24\,750\pi \text{ lb-in}$$

$$T = 77.75 \text{ kip-in}$$

Use $T = 77.75 \text{ kip-in}$

Problem 332

In a rivet group subjected to a twisting couple T , show that the torsion formula $\tau = T\rho/J$ can be used to find the shearing stress t at the center of any rivet. Let $J = \Sigma A\rho^2$, where A is the area of a rivet at the radial distance ρ from the centroid of the rivet group.

Solution 332

The shearing stress on each rivet is P/A

$$\tau = T\rho/J$$

Where: $T = PRn$
 $\rho = R$
 $J = \Sigma A\rho^2 = AR^2n$

$$\tau = \frac{PRn(R)}{AR^2n}$$

$$\tau = \frac{P}{A} \quad (\text{ok!})$$

This shows that $\tau = T\rho/J$ can be used to find the shearing stress at the center of any rivet.

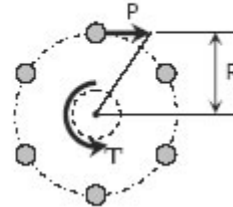

Problem 333

A plate is fastened to a fixed member by four 20-mm diameter rivets arranged as shown in Fig. P-333. Compute the maximum and minimum shearing stress developed.

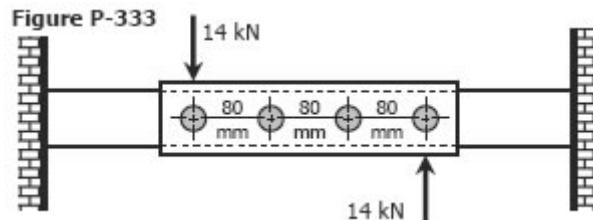

Solution 333

$$\tau = \frac{T\rho}{J}$$

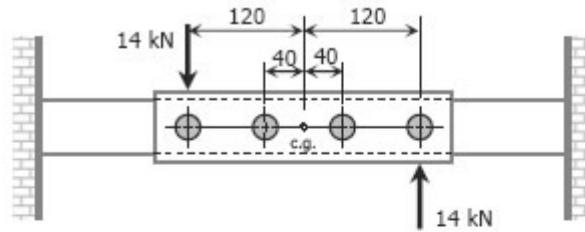

Where:

$$T = 14(1000)(120) = 1\,680\,000 \text{ N}\cdot\text{mm}$$

$$J = \sum A\rho^2 = \frac{1}{4}(\pi)(20)^2 [2(40^2) + 2(120^2)]$$

$$= 3\,200\,000\pi \text{ mm}^4$$

Maximum shearing stress ($\rho = 120 \text{ mm}$):

$$\tau_{\max} = \frac{1\,680\,000(120)}{3\,200\,000\pi}$$

$$\tau_{\max} = 20.05 \text{ MPa}$$

Minimum shearing stress ($\rho = 40 \text{ mm}$):

$$\tau_{\min} = \frac{1\,680\,000(40)}{3\,200\,000\pi}$$

$$\tau_{\min} = 6.68 \text{ MPa}$$

Problem 334

Six 7/8-in-diameter rivets fasten the plate in Fig. P-334 to the fixed member. Using the results of Prob. 332, determine the average shearing stress caused in each rivet by the 14 kip loads. What additional loads P can be applied before the shearing stress in any rivet exceeds 8000 psi?

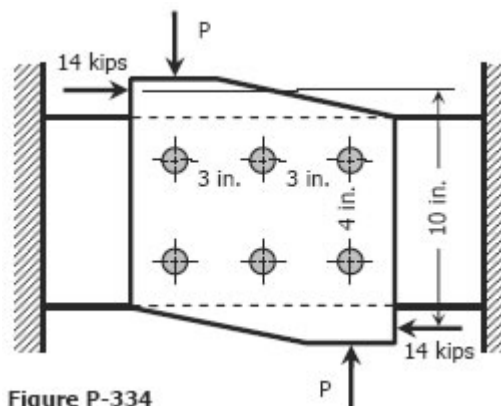

Figure P-334

Solution 334

Without the loads P :

$$\tau = \frac{T\rho}{J}$$

Where: $T = 14(10) = 140 \text{ kip-in}$

$$\rho = \sqrt{13} \text{ in}$$

$$J = \sum A\rho^2 = \frac{1}{4} (\pi n)^2 \left[4(\sqrt{13})^2 + 2(2)^2 \right] = 36.08 \text{ in}^4$$

$$\tau_{\text{maximum}} = \frac{140(\sqrt{13})}{36.08} = 14.0 \text{ ksi}$$

$$\tau_{\text{minimum}} = \frac{140(2)}{36.08} = 7.76 \text{ ksi}$$

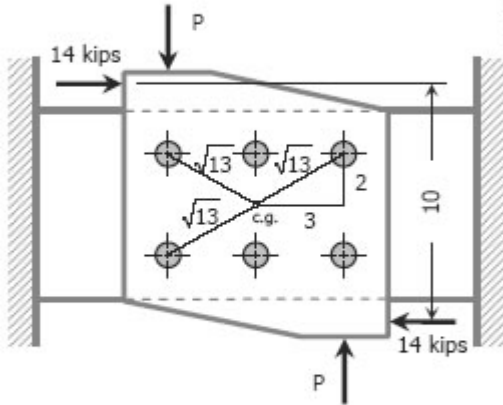

With the loads P , two cases will arise:

1st case ($P < 14 \text{ kips}$)

$$T = 10(14) - 6P = (140 - 6P) \text{ kip-in}$$

$$\tau = \frac{T\rho}{J}$$

$$8000 = \frac{(140 - 6P)(1000)(\sqrt{13})}{36.08}$$

$$80.05 = 140 - 6P$$

$$P = 10.0 \text{ kips}$$

2nd case ($P > 14 \text{ kips}$)

$$T = 6P - 10(14) = (6P - 140) \text{ kip-in}$$

$$\tau = \frac{T\rho}{J}$$

$$8000 = \frac{(6P - 140)(1000)(\sqrt{13})}{36.08}$$

$$80.05 = 6P - 140$$

$$P = 36.68 \text{ kips}$$

Problem 335

The plate shown in Fig. P-335 is fastened to the fixed member by five 10-mm-diameter rivets. Compute the value of the loads P so that the average shearing stress in any rivet does not exceed 70 MPa. (Hint: Use the results of Prob. 332.)

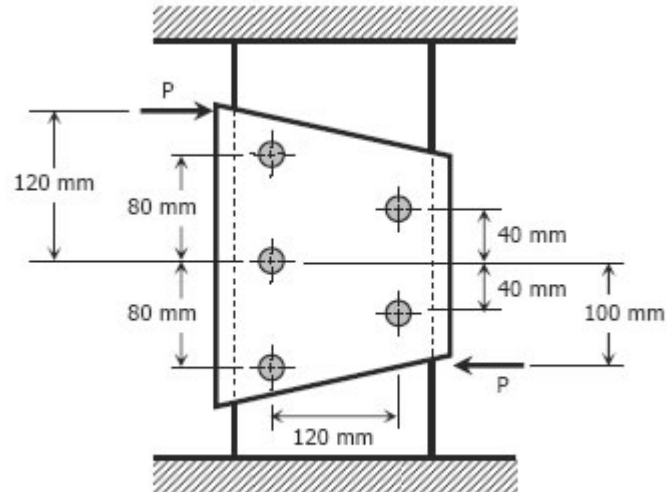

Figure P-335

Solution 335

Solving for location of centroid of rivets:

$$A X_G = \sum ax$$

$$\text{Where } A = \frac{1}{2} (80 + 160)(80) = 9600 \text{ mm}^2$$

$$a_1 = a_2 = a_3 = \frac{1}{2} (80)(80) = 3200 \text{ mm}^2$$

$$x_1 = x_3 = \frac{1}{3} (80) = 80/3 \text{ mm}$$

$$x_2 = \frac{2}{3} (80) = 160/3 \text{ mm}$$

$$9600 X_G = 3200(80/3) + 3200(160/3) + 3200(80/3)$$

$$X_G = 320/9 \text{ mm}$$

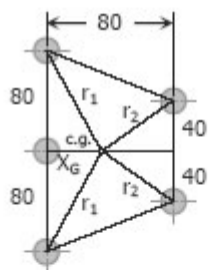
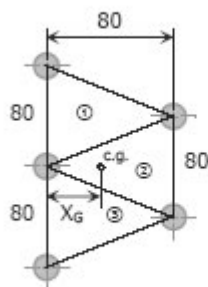

$$r_1 = \sqrt{(320/9)^2 + 80^2} = 87.54 \text{ mm}$$

$$r_2 = \sqrt{(80 - 320/9)^2 + 40^2} = 59.79 \text{ mm}$$

$$J = \sum A\rho^2 = \frac{1}{4} \pi (10^2) (2r_1^2 + 2r_2^2 + X_G^2)$$

$$J = \frac{1}{4} \pi (10^2) [2(87.54)^2 + 2(59.79)^2 + (320/9)^2]$$

$$J = 1\,864\,565.79 \text{ mm}^4$$

$$T = (120 + 100)P = 220P$$

The critical rivets are at distance r_1 from centroid:

$$\tau = \frac{T\rho}{J}$$

$$70 = \frac{220P(87.54)}{1\,864\,565.79}$$

$$P = 6777.14 \text{ N}$$

Torsion of Thin-Walled Tubes

The torque applied to thin-walled tubes is expressed as

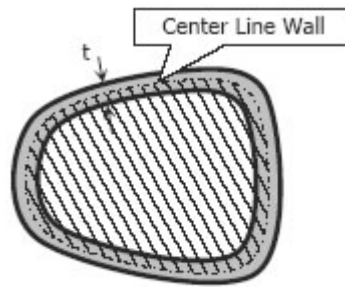

$$T = 2Aq$$

where T is the torque in $\text{N}\cdot\text{mm}$, A is the area enclosed by the centerline of the tube (as shown in the stripefilled portion) in mm^2 , and q is the shear flow in N/mm .

The average shearing stress across any thickness t is

$$\tau = \frac{q}{t} = \frac{T}{2At}$$

Thus, torque T can also be expressed as

$$T = 2At\tau$$

Solved Problems in Torsion of Thin-Walled Tubes

Problem 337

A torque of $600 \text{ N}\cdot\text{m}$ is applied to the rectangular section shown in Fig. P-337.

Determine the wall thickness t so as not to exceed a shear stress of 80 MPa . What is the shear stress in the short sides? Neglect stress concentration at the corners.

Solution 337

$$T = 2At\tau$$

$$\text{Where: } T = 600 \text{ N}\cdot\text{m} = 600\,000 \text{ N}\cdot\text{mm}$$

$$A = 30(80) = 2400 \text{ mm}^2$$

$$\tau = 80 \text{ MPa}$$

$$600\,000 = 2(2400)(t)(80)$$

$$t = 1.5625 \text{ mm}$$

At any convenient center O within the section, the farthest side is the shortest side, thus, it is induced with the maximum allowable shear stress of 80 MPa .

Problem 338

A tube 0.10 in. thick has an elliptical shape shown in Fig. P-338. What torque will cause a shearing stress of 8000 psi?

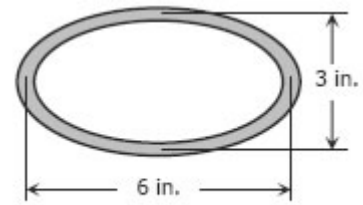
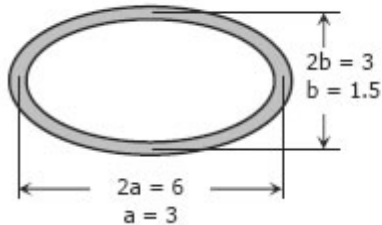

Figure P-338

Solution 338

$$T = 2At\tau$$

Where: $A = \pi ab = \pi(3)(1.5) = 4.5\pi \text{ in}^2$
 $t = 0.10 \text{ in}$
 $\tau = 8000 \text{ psi}$

$$T = 2(4.5\pi)(0.10)(8000)$$

$$T = 22619.47 \text{ lb-in}$$

$$T = 22.62 \text{ kip-in}$$

Problem 339

A torque of 450 lb-ft is applied to the square section shown in Fig. P-339. Determine the smallest permissible dimension a if the shearing stress is limited to 6000 psi.

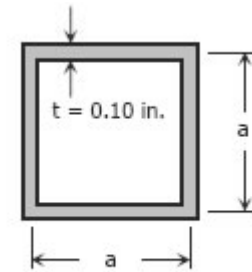

Figure P-339

Solution 339

$$T = 2At\tau$$

Where: $T = 450 \text{ lb-ft}$
 $T = 450(12) \text{ lb-in}$
 $A = a^2$
 $\tau = 6000 \text{ psi}$
 $450(12) = 2a^2(0.10)(6000)$
 $a = 2.12 \text{ in}$

Problem 340

A tube 2 mm thick has the shape shown in Fig. P-340. Find the shearing stress caused by a torque of 600 N·m.

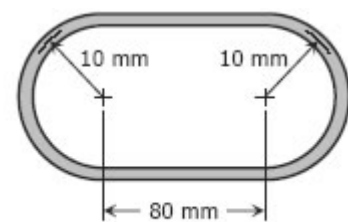

Figure P-340

Solution 340

$$T = 2At\tau$$

Where: $A = \pi(10^2) + 80(20) = 1914.16 \text{ mm}^2$
 $t = 2 \text{ mm}$
 $T = 600 \text{ N-m} = 600\,000 \text{ N-mm}$

$$600\,000 = 2(1914.16)(2)\tau$$

$$\tau = 78.36 \text{ MPa}$$

Problem 341

Derive the torsion formula $\tau = T\rho/J$ for a solid circular section by assuming the section is composed of a series of concentric thin circular tubes. Assume that the shearing stress at any point is proportional to its radial distance.

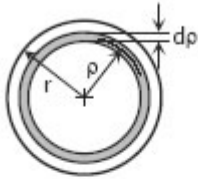
Solution 341

$$T = 2At\tau$$

$$\text{Where: } T = dT; A = \pi\rho^2; t = d\rho$$

$$\frac{\tau}{\rho} = \frac{\tau_{\max}}{r}; \tau = \frac{\tau_{\max}\rho}{r}$$

$$dT = 2\pi(\rho^2) d\rho \left(\frac{\tau_{\max}\rho}{r} \right)$$

$$T = \frac{2\pi\tau_{\max}}{r} \int_0^r \rho^3 d\rho$$

$$T = \frac{2\pi\tau_{\max}}{r} \left[\frac{\rho^4}{4} \right]_0^r$$

$$T = \frac{2\pi\tau_{\max}}{r} \left(\frac{r^4}{4} \right)$$

$$T = \frac{\tau_{\max}}{r} \left(\frac{\pi r^4}{2} \right)$$

$$T = \frac{\tau_{\max}}{r} J$$

$$\tau_{\max} = \frac{Tr}{J} \text{ and it follows that } \tau = \frac{T\rho}{J}$$

Helical Springs

When close-coiled helical spring, composed of a wire of round rod of diameter d wound into a helix of mean radius R with n number of turns, is subjected to an axial load P produces the following stresses and elongation:

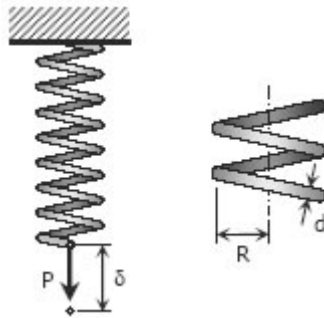

The maximum shearing stress is the sum of the direct shearing stress $\tau_1 = P/A$ and the torsional shearing stress $\tau_2 = Tr/J$, with $T = PR$.

$$\tau = \tau_1 + \tau_2 = \frac{P}{\pi d^2/4} + \frac{16(PR)}{\pi d^3}$$

$$\tau = \frac{16PR}{\pi d^3} \left(1 + \frac{d}{4R} \right)$$

This formula neglects the curvature of the spring. This is used for light spring where the ratio $d/4R$ is small.

For heavy springs and considering the curvature of the spring, a more precise formula is given by: (A.M.Wahl Formula)

$$\tau = \frac{16PR}{\pi d^3} \left(\frac{4m-1}{4m-4} + \frac{0.615}{m} \right)$$

where m is called the spring index and $(4m - 1) / (4m - 4)$ is the Wahl Factor.

The elongation of the bar is

$$\delta = \frac{64PR^3n}{Gd^4}$$

Notice that the deformation δ is directly proportional to the applied load P . The ratio of P to δ is called the spring constant k and is equal to

$$k = \frac{P}{\delta} = \frac{Gd^4}{64R^3n} \text{ in N/mm}$$

SPRINGS IN SERIES

For two or more springs with spring laid in series, the resulting spring constant k is given by

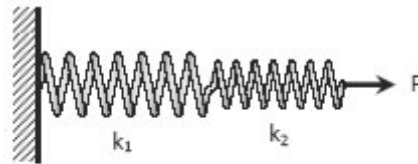

$$1/k = 1/k_1 + 1/k_2 + \dots$$

where k_1, k_2, \dots are the spring constants for different springs.

SPRINGS IN PARALLEL

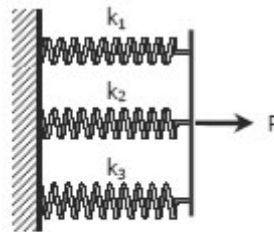

$$k = k_1 + k_2 + \dots$$

Solved Problems in Helical Springs

Problem 343

Determine the maximum shearing stress and elongation in a helical steel spring composed of 20 turns of 20-mm-diameter wire on a mean radius of 90 mm when the spring is supporting a load of 1.5 kN. Use Eq. (3-10) and $G = 83$ GPa.

Solution 343

$$\tau_{\max} = \frac{16PR}{\pi d^3} \left(\frac{4m-1}{4m-4} + \frac{0.615}{m} \right) \quad \rightarrow \text{Equation (3-10)}$$

Where $P = 1.5 \text{ kN} = 1500 \text{ N}$; $R = 90 \text{ mm}$
 $d = 20 \text{ mm}$; $n = 20 \text{ turns}$
 $m = 2R/d = 2(90)/20 = 9$

$$\tau_{\max} = \frac{16(1500)(90)}{\pi(20^3)} \left[\frac{4(9)-1}{4(9)-4} + \frac{0.615}{9} \right]$$

$$\tau_{\max} = 99.87 \text{ MPa}$$

$$\delta = \frac{64PR^3n}{Gd^4} = \frac{64(1500)(90^3)(20)}{83\,000(20^4)}$$

$$\delta = 105.4 \text{ mm}$$

Problem 344

Determine the maximum shearing stress and elongation in a bronze helical spring composed of 20 turns of 1.0-in.-diameter wire on a mean radius of 4 in. when the spring is supporting a load of 500 lb. Use Eq. (3-10) and $G = 6 \times 10^6$ psi.

Solution 344

$$\tau_{\max} = \frac{16PR}{\pi d^3} \left(\frac{4m-1}{4m-4} + \frac{0.615}{m} \right) \quad \rightarrow \text{Equation (3-10)}$$

Where $P = 500$ lb; $R = 4$ in
 $d = 1$ in; $n = 20$ turns
 $m = 2R/d = 2(4)/1 = 8$

$$\tau_{\max} = \frac{16(500)(4)}{\pi(1^3)} \left[\frac{4(8)-1}{4(8)-4} + \frac{0.615}{8} \right]$$

$$\tau_{\max} = 12\,060.3 \text{ psi} = \mathbf{12.1 \text{ ksi}}$$

$$\delta = \frac{64PR^3n}{Gd^4} = \frac{64(500)(4^3)(20)}{(6 \times 10^6)(1^4)}$$

$$\delta = \mathbf{6.83 \text{ in}}$$

Problem 345

A helical spring is fabricated by wrapping wire $\frac{3}{4}$ in. in diameter around a forming cylinder 8 in. in diameter. Compute the number of turns required to permit an elongation of 4 in. without exceeding a shearing stress of 18 ksi. Use Eq. (3-9) and $G = 12 \times 10^6$ psi.

Solution 345

$$\tau_{\max} = \frac{16PR}{\pi d^3} \left(1 + \frac{d}{4R} \right) \quad \rightarrow \text{Equation (3-9)}$$

$$18000 = \frac{16P(4)}{\pi(3/4)^3} \left[1 + \frac{3/4}{4(4)} \right]$$

$$P = 356.07 \text{ lb}$$

$$\delta = \frac{64PR^3n}{Gd^4}$$

$$4 = \frac{64(356.07)(4^3)n}{(12 \times 10^6)(3/4)^3}$$

$$n = 13.88 \text{ say } \mathbf{14 \text{ turns}}$$

Problem 346

Compute the maximum shearing stress developed in a phosphor bronze spring having mean diameter of 200 mm and consisting of 24 turns of 200-mm-diameter wire when the spring is stretched 100 mm. Use Eq. (3-10) and $G = 42$ GPa.

Solution 346

$$\delta = \frac{64PR^3}{Gd^4}$$

Where $\delta = 100 \text{ mm}; R = 100 \text{ mm}$
 $d = 20 \text{ mm}; n = 24 \text{ turns}$
 $G = 42\,000 \text{ MPa}$

$$100 = \frac{64P(100^3)24}{42\,000(20^4)}$$

$$P = 437.5 \text{ N}$$

$$\tau_{\max} = \frac{16PR}{\pi d^3} \left(\frac{4m-1}{4m-4} + \frac{0.615}{m} \right) \quad \rightarrow \text{Equation (3-10)}$$

Where $m = 2R/d$
 $= 2(100)/20 = 10$

$$\tau_{\max} = \frac{16(437.5)(100)}{\pi(20^3)} \left[\frac{2(10)-1}{2(10)-4} + \frac{0.615}{10} \right]$$

$$\tau_{\max} = 34.79 \text{ MPa}$$

Problem 347

Two steel springs arranged in series as shown in Fig. P-347 supports a load P . The upper spring has 12 turns of 25-mm-diameter wire on a mean radius of 100 mm. The lower spring consists of 10 turns of 20-mm diameter wire on a mean radius of 75 mm. If the maximum shearing stress in either spring must not exceed 200 MPa, compute the maximum value of P and the total elongation of the assembly. Use Eq. (3-10) and $G = 83 \text{ GPa}$. Compute the equivalent spring constant by dividing the load by the total elongation.

Solution 347

$$\tau_{\max} = \frac{16PR}{\pi d^3} \left(\frac{4m-1}{4m-4} + \frac{0.615}{m} \right) \rightarrow \text{Equation 3-10}$$

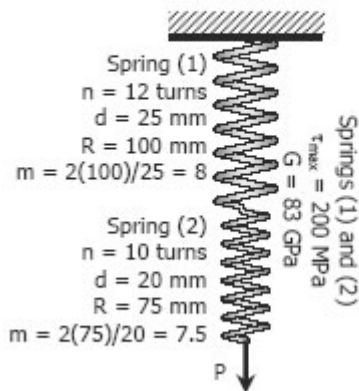

For Spring (1)

$$200 = \frac{16P(100)}{\pi(25^3)} \left[\frac{4(8)-1}{4(8)-4} + \frac{0.615}{8} \right]$$

$$P = 5182.29 \text{ N}$$

For Spring (2)

$$200 = \frac{16P(75)}{\pi(20^3)} \left[\frac{4(7.5)-1}{4(7.5)-4} + \frac{0.615}{7.5} \right]$$

$$P = 3498.28 \text{ N}$$

Use $P = 3498.28 \text{ N}$

Total elongation:

$$\delta = \delta_1 + \delta_2$$

$$\delta = \left(\frac{64PR^3n}{Gd^4} \right)_1 + \left(\frac{64PR^3n}{Gd^4} \right)_2$$

$$\delta = \frac{64(3498.28)(100^3)12}{83\,000(25^4)} + \frac{64(3498.28)(75^3)(10)}{83\,000(20^4)}$$

$$\delta = 153.99 \text{ mm}$$

Equivalent spring constant, $k_{\text{equivalent}}$:

$$k_{\text{equivalent}} = \frac{P}{\delta} = \frac{3498.28}{153.99}$$

$$k_{\text{equivalent}} = 22.72 \text{ N/mm}$$

Problem 348

A rigid bar, pinned at O, is supported by two identical springs as shown in Fig. P-348. Each spring consists of 20 turns of $\frac{3}{4}$ -in-diameter wire having a mean diameter of 6 in. Determine the maximum load W that may be supported if the shearing stress in the springs is limited to 20 ksi. Use Eq. (3-9).

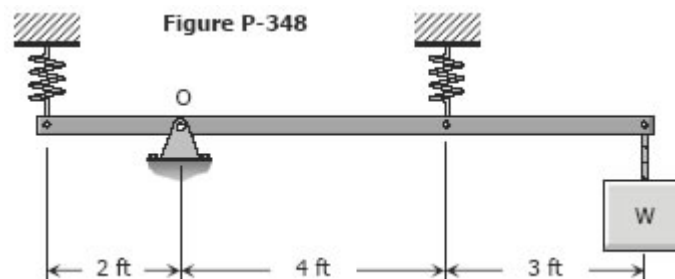

Solution 348

$$\tau_{\max} = \frac{16PR}{\pi d^3} \left(1 + \frac{d}{4R} \right) \quad \rightarrow \text{Equation (3-9)}$$

$$20\,000 = \frac{16P(3)}{\pi(3/4)^3} \left[1 + \frac{3/4}{4(3)} \right]$$

$$P = 519.75 \text{ lb}$$

For this problem, the critical spring is the one subjected to tension. Use $P_2 = 519.75 \text{ lb}$.

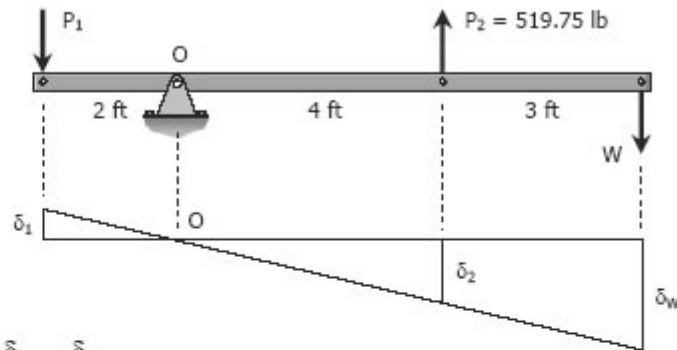

$$\frac{\delta_1}{2} = \frac{\delta_2}{4}$$

$$\delta_1 = \frac{1}{2} \delta_2$$

$$\frac{64P_1R^3n}{Gd^4} = \frac{1}{2} \left(\frac{64P_2R^3n}{Gd^4} \right)$$

$$P_1 = \frac{1}{2} P_2 = \frac{1}{2} (519.75)$$

$$P_1 = 259.875 \text{ lb}$$

$$\sum M_O = 0$$

$$7W = 2P_1 + 4P_2$$

$$7W = 2(259.875) + 4(519.75)$$

$$W = 371.25 \text{ lb}$$

Problem 349

A rigid bar, hinged at one end, is supported by two identical springs as shown in Fig. P-349. Each spring consists of 20 turns of 10-mm wire having a mean diameter of 150 mm. Compute the maximum shearing stress in the springs, using Eq. (3-9). Neglect the mass of the rigid bar.

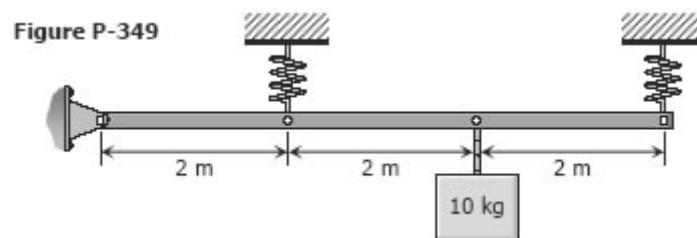

Solution 349

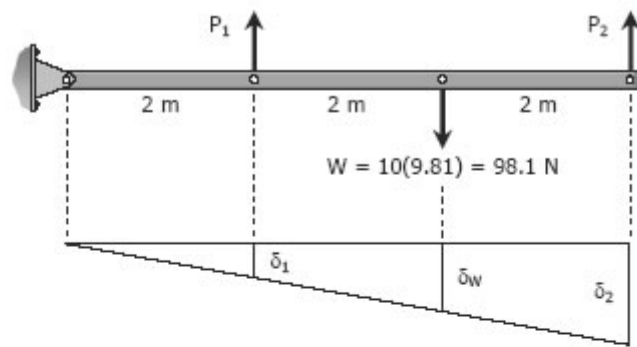

$$\frac{\delta_1}{2} = \frac{\delta_2}{6}$$

$$\delta_1 = \frac{1}{3} \delta_2$$

$$\frac{64P_1R^3n}{Gd^4} = \frac{1}{3} \left(\frac{64P_2R^3n}{Gd^4} \right)$$

$$P_1 = \frac{1}{3} P_2$$

$$\Sigma M_{\text{at hinged support}} = 0$$

$$2P_1 + 6P_2 = 4(98.1)$$

$$2\left(\frac{1}{3} P_2\right) + 6P_2 = 4(98.1)$$

$$P_2 = 58.86 \text{ N}$$

$$P_1 = \frac{1}{3} (58.86) = 19.62 \text{ N}$$

$$\tau_{\max} = \frac{16PR}{\pi d^3} \left(1 + \frac{d}{4R} \right) \quad \rightarrow \text{Equation (3-9)}$$

For spring at left:

$$\tau_{\max 1} = \frac{16(19.62)(75)}{\pi(10^3)} \left[1 + \frac{10}{4(75)} \right]$$

$$\tau_{\max 1} = 7.744 \text{ MPa}$$

For spring at right:

$$\tau_{\max 2} = \frac{16(58.86)(75)}{\pi(10^3)} \left[1 + \frac{10}{4(75)} \right]$$

$$\tau_{\max 2} = 23.232 \text{ MPa}$$

Problem 350

As shown in Fig. P-350, a homogeneous 50-kg rigid block is suspended by the three springs whose lower ends were originally at the same level. Each steel spring has 24 turns of 10-mm-diameter on a mean diameter of 100 mm, and $G = 83$ GPa. The bronze spring has 48 turns of 20-mm-diameter wire on a mean diameter of 150 mm, and $G = 42$ GPa. Compute the maximum shearing stress in each spring using Eq. (3-9).

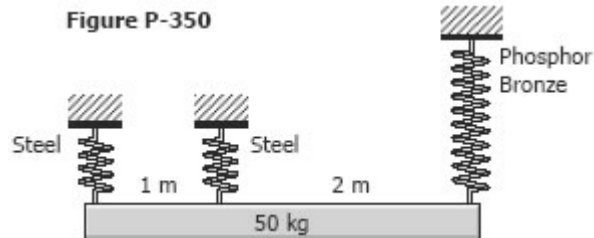

Solution 350

$$\begin{aligned} \sum F_V = 0 \\ P_1 + P_2 + P_3 = 490.5 \end{aligned} \quad \rightarrow \text{Equation (1)}$$

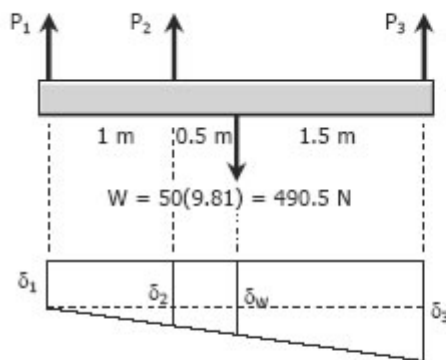

$$\begin{aligned} \sum M_1 = 0 \\ P_2(1) + P_3(3) = 490.5(1.5) \\ P_2 + 3P_3 = 735.75 \end{aligned} \quad \rightarrow \text{Equation (2)}$$

$$\frac{\delta_2 - \delta_1}{1} = \frac{\delta_3 - \delta_1}{3}$$

$$\delta_2 = \frac{1}{3} \delta_3 + \frac{2}{3} \delta_1$$

$$\begin{aligned} \frac{64P_2(50^3)(24)}{83000(10^4)} = \frac{1}{3} \left[\frac{64P_3(75^3)(48)}{42000(20^4)} \right] \\ + \frac{2}{3} \left[\frac{64P_1(50^3)(24)}{83000(10^4)} \right] \end{aligned}$$

$$\frac{3}{830} P_2 = \frac{9}{8960} P_3 + \frac{1}{415} P_1$$

$$\frac{3}{166} P_2 = \frac{9}{1792} P_3 + \frac{1}{83} P_1 \quad \rightarrow \text{Equation (3)}$$

From Equation (1)

$$P_1 = 490.5 - P_2 - P_3$$

Substitute P_1 to Equation (3)

$$\frac{3}{166} P_2 = \frac{9}{1792} P_3 + \frac{1}{83} (490.5 - P_2 - P_3)$$

$$\frac{3}{166} P_2 = \frac{9}{1792} P_3 + \frac{981}{166} - \frac{1}{83} P_2 - \frac{1}{83} P_3$$

$$\frac{5}{166} P_2 = \frac{981}{166} - \frac{1045}{148736} P_3 \quad \rightarrow \text{Equation (4)}$$

From Equation (2)

$$P_2 = 735.75 - 3P_3 = \frac{2943}{4} - 3P_3$$

Substitute P_2 to Equation (4)

$$\frac{5}{166} \left(\frac{2943}{4} - 3P_3 \right) = \frac{981}{166} - \frac{1045}{148736} P_3$$

$$\left(\frac{1045}{148736} - \frac{15}{166} \right) P_3 = \frac{981}{166} - \frac{14715}{664}$$

$$P_3 = 195.01 \text{ N}$$

$$P_2 = 735.75 - 3(195.01) = 150.72 \text{ N}$$

$$P_1 = 490.5 - 150.72 - 195.01 = 144.77 \text{ N}$$

$$\tau_{\max} = \frac{16PR}{\pi d^3} \left(1 + \frac{d}{4R} \right) \quad \rightarrow \text{Equation (3-9)}$$

For steel at left:

$$\tau_{\max 1} = \frac{16(144.77)(50)}{\pi(10^3)} \left[1 + \frac{10}{4(50)} \right] = 38.709 \text{ MPa}$$

For steel at right:

$$\tau_{\max 1} = \frac{16(150.72)(50)}{\pi(10^3)} \left[1 + \frac{10}{4(50)} \right] = 40.300 \text{ MPa}$$

For phosphor bronze:

$$\tau_{\max 3} = \frac{16(195.01)(75)}{\pi(20^3)} \left[1 + \frac{20}{4(75)} \right] = 9.932 \text{ MPa}$$

Shear & Moment in Beams

DEFINITION OF A BEAM

A beam is a bar subject to forces or couples that lie in a plane containing the longitudinal of the bar. According to determinacy, a beam may be determinate or indeterminate.

STATICALLY DETERMINATE BEAMS

Statically determinate beams are those beams in which the reactions of the supports may be determined by the use of the equations of static equilibrium. The beams shown below are examples of statically determinate beams.

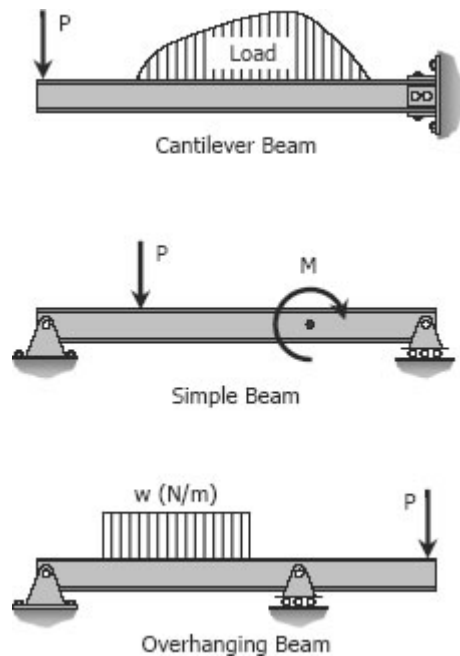

STATICALLY INDETERMINATE BEAMS

If the number of reactions exerted upon a beam exceeds the number of equations in static equilibrium, the beam is said to be statically indeterminate. In order to solve the reactions of the beam, the static equations must be supplemented by equations based upon the elastic deformations of the beam.

The degree of indeterminacy is taken as the difference between the number of reactions to the number of equations in static equilibrium that can be applied. In the case of the propped beam shown, there are three reactions R_1 , R_2 , and M and only two equations ($\sum M = 0$ and $\sum F_v = 0$) can be applied, thus the beam is indeterminate to the first degree ($3 - 2 = 1$).

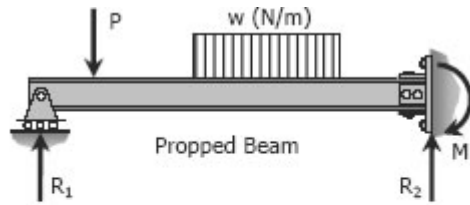

Propped Beam

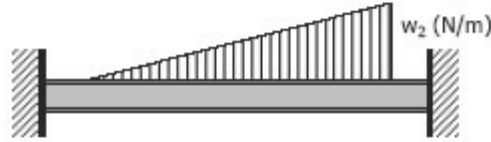

Fixed or Restrained Beam

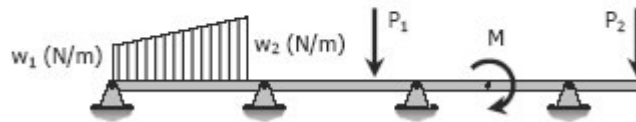

Continuous Beam

TYPES OF LOADING

Loads applied to the beam may consist of a concentrated load (load applied at a point), uniform load, uniformly varying load, or an applied couple or moment. These loads are shown in the following figures.



Concentrated Loads

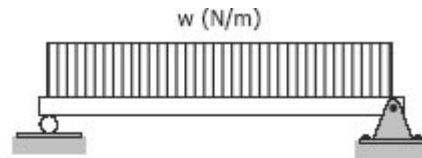

Uniform Load

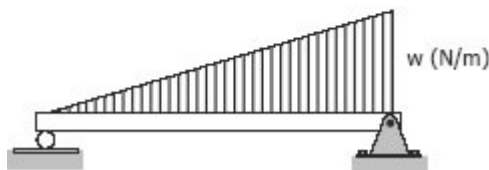

Uniformly Varying Load

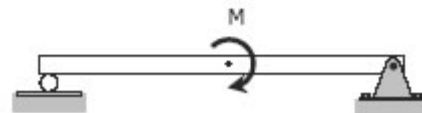

Applied Couple

Shear and Moment Diagrams

Consider a simple beam shown of length L that carries a uniform load of w (N/m) throughout its length and is held in equilibrium by reactions R_1 and R_2 . Assume that the beam is cut at point C a distance of x from the left support and the portion of the beam to the right of C be removed. The portion removed must then be replaced by vertical shearing force V together with a couple M to hold the left portion of the bar in equilibrium under the action of R_1 and $w x$. The couple M is called the resisting moment or moment and the force V is called the resisting shear or shear. The sign of V and M are taken to be positive if they have the senses indicated above.

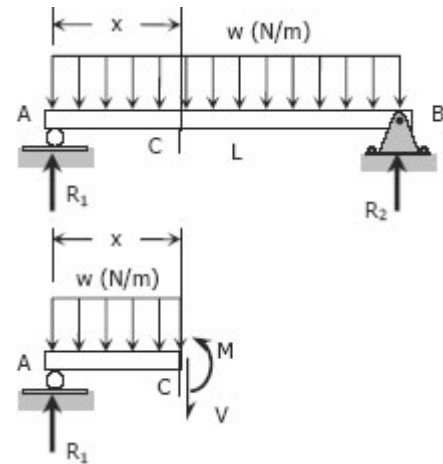

The couple M is called the resisting moment or moment and the force V is called the resisting shear or shear. The sign of V and M are taken to be positive if they have the senses indicated above.

Solved Problems in Shear and Moment Diagrams

INSTRUCTION

Write shear and moment equations for the beams in the following problems. In each problem, let x be the distance measured from left end of the beam. Also, draw shear and moment diagrams, specifying values at all change of loading positions and at points of zero shear. Neglect the mass of the beam in each problem.

Problem 403

Beam loaded as shown in Fig. P-403.

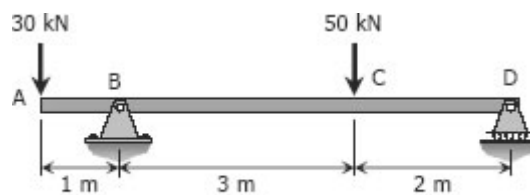

Figure P-403

Solution 403

From the load diagram:

$$\begin{aligned}\sum M_B &= 0 \\ 5R_D + 1(30) &= 3(50) \\ R_D &= 24 \text{ kN}\end{aligned}$$

$$\begin{aligned}\sum M_D &= 0 \\ 5R_B &= 2(50) + 6(30) \\ R_B &= 56 \text{ kN}\end{aligned}$$

Segment AB:

$$\begin{aligned}V_{AB} &= -30 \text{ kN} \\ M_{AB} &= -30x \text{ kN}\cdot\text{m}\end{aligned}$$

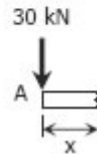

Segment BC:

$$\begin{aligned}V_{BC} &= -30 + 56 \\ &= 26 \text{ kN} \\ M_{BC} &= -30x + 56(x - 1) \\ &= 26x - 56 \text{ kN}\cdot\text{m}\end{aligned}$$

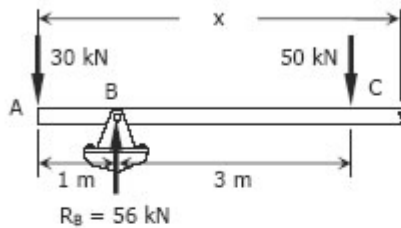
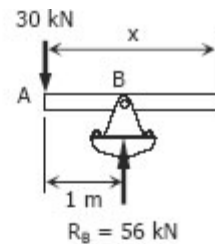

Segment CD:

$$\begin{aligned}V_{CD} &= -30 + 56 - 50 \\ &= -24 \text{ kN} \\ M_{CD} &= -30x + 56(x - 1) - 50(x - 4) \\ &= -30x + 56x - 56 - 50x + 200 \\ &= -24x + 144\end{aligned}$$

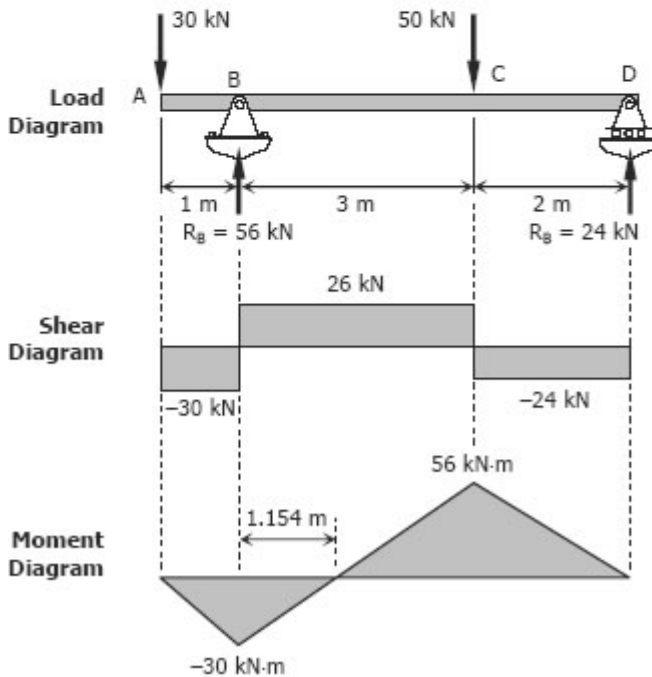

To draw the Shear Diagram:

- (1) In segment AB, the shear is uniformly distributed over the segment at a magnitude of -30 kN.
- (2) In segment BC, the shear is uniformly distributed at a magnitude of 26 kN.
- (3) In segment CD, the shear is uniformly distributed at a magnitude of -24 kN.

To draw the Moment Diagram:

- (1) The equation $M_{AB} = -30x$ is linear, at $x = 0$, $M_{AB} = 0$ and at $x = 1$ m, $M_{AB} = -30$ kN-m.
- (2) $M_{BC} = 26x - 56$ is also linear. At $x = 1$ m, $M_{BC} = -30$ kN-m; at $x = 4$ m, $M_{BC} = 48$ kN-m. When $M_{BC} = 0$, $x = 2.154$ m, thus the moment is zero at 1.154 m from B.
- (3) $M_{CD} = -24x + 144$ is again linear. At $x = 4$ m, $M_{CD} = 48$ kN-m; at $x = 6$ m, $M_{CD} = 0$.

Problem 404

Beam loaded as shown in Fig. P-404.

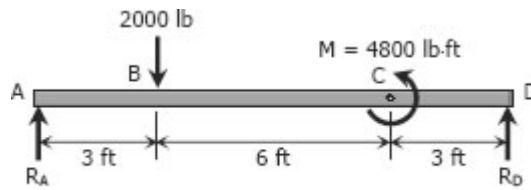

Figure P-404

Solution 404

$$\begin{array}{l|l} \sum M_A = 0 & \sum M_D = 0 \\ 12R_D + 4800 = 3(2000) & 12R_A = 9(2000) + 4800 \\ R_D = 100 \text{ lb} & R_A = 1900 \text{ lb} \end{array}$$

Segment AB:

$$V_{AB} = 1900 \text{ lb}$$

$$M_{AB} = 1900x \text{ lb-ft}$$

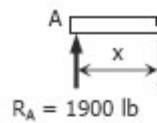

Segment BC:

$$V_{BC} = 1900 - 2000$$

$$= -100 \text{ lb}$$

$$M_{BC} = 1900x - 2000(x - 3)$$

$$= 1900x - 2000x + 6000$$

$$= -100x + 6000$$

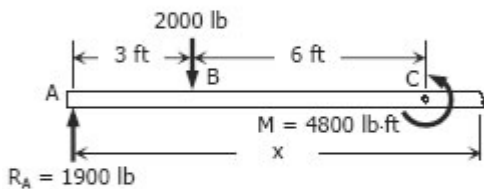
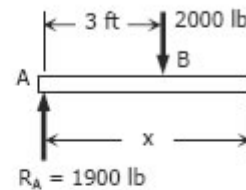

Segment CD:

$$V_{CD} = 1900 - 2000$$

$$= -100 \text{ lb}$$

$$M_{CD} = 1900x - 2000(x - 3) - 4800$$

$$= 1900x - 2000x + 6000 - 4800$$

$$= -100x + 1200$$

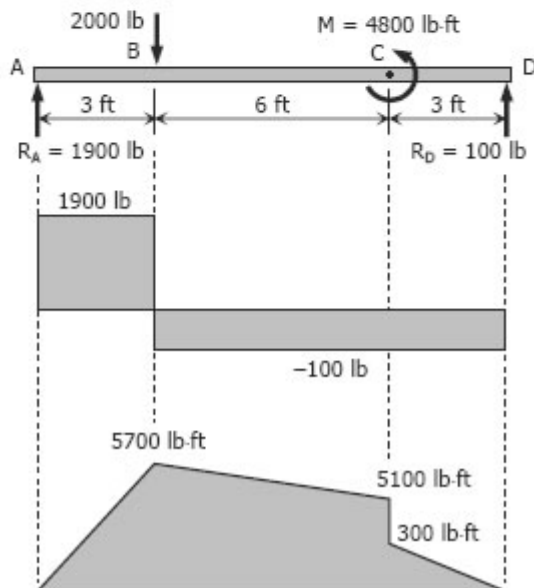

Load Diagram

Shear Diagram

Moment Diagram

To draw the Shear Diagram:

- (1) At segment AB, the shear is uniformly distributed at 1900 lb.
- (2) A shear of -100 lb is uniformly distributed over segments BC and CD.

To draw the Moment Diagram:

- (1) $M_{AB} = 1900x$ is linear; at $x = 0$, $M_{AB} = 0$; at $x = 3$ ft, $M_{AB} = 5700$ lb-ft.
- (2) For segment BC, $M_{BC} = -100x + 6000$ is linear; at $x = 3$ ft, $M_{BC} = 5700$ lb-ft; at $x = 9$ ft, $M_{BC} = 5100$ lb-ft.
- (3) $M_{CD} = -100x + 1200$ is again linear; at $x = 9$ ft, $M_{CD} = 300$ lb-ft; at $x = 12$ ft, $M_{CD} = 0$.

Problem 405

Beam loaded as shown in Fig. P-405.

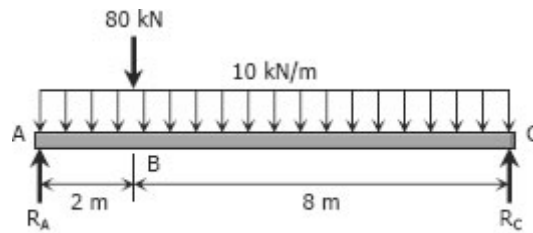
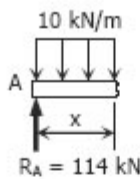

Figure P-405

Solution 405

$$\begin{aligned} \sum M_A = 0 \\ 10R_C = 2(80) + 5[10(10)] \\ R_C = 66 \text{ kN} \end{aligned}$$

$$\begin{aligned} \sum M_C = 0 \\ 10R_A = 8(80) + 5[10(10)] \\ R_A = 114 \text{ kN} \end{aligned}$$



Segment AB:

$$\begin{aligned} V_{AB} &= 114 - 10x \text{ kN} \\ M_{AB} &= 114x - 10x(x/2) \\ &= 114x - 5x^2 \text{ kN}\cdot\text{m} \end{aligned}$$

Segment BC:

$$\begin{aligned} V_{BC} &= 114 - 80 - 10x \\ &= 34 - 10x \text{ kN} \\ M_{BC} &= 114x - 80(x - 2) - 10x(x/2) \\ &= 160 + 34x - 5x^2 \end{aligned}$$

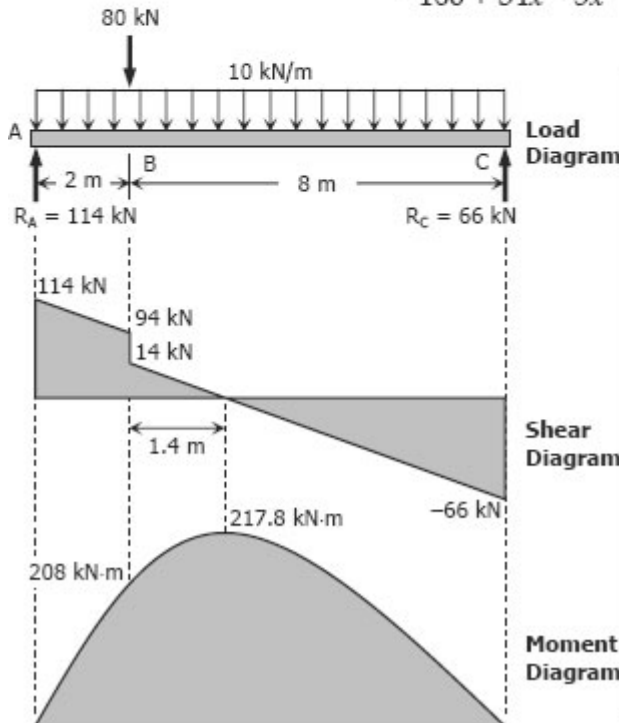
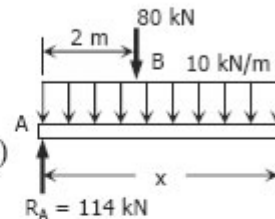

To draw the Shear Diagram:

- For segment AB, $V_{AB} = 114 - 10x$ is linear; at $x = 0$, $V_{AB} = 114$ kN; at $x = 2$ m, $V_{AB} = 14$ kN.
- $V_{BC} = 34 - 10x$ for segment BC is linear; at $x = 2$ m, $V_{BC} = 14$ kN; at $x = 10$ m, $V_{BC} = -66$ kN. When $V_{BC} = 0$, $x = 3.4$ m thus $V_{BC} = 0$ at 1.4 m from B.

To draw the Moment Diagram:

- $M_{AB} = 114x - 5x^2$ is a second degree curve for segment AB; at $x = 0$, $M_{AB} = 0$; at $x = 2$ m, $M_{AB} = 208$ kN-m.
- The moment diagram is also a second degree curve for segment BC given by $M_{BC} = 160 + 34x - 5x^2$; at $x = 2$ m, $M_{BC} = 208$ kN-m; at $x = 10$ m, $M_{BC} = 0$.
- Note that the maximum moment occurs at point of zero shear. Thus, at $x = 3.4$ m, $M_{BC} = 217.8$ kN-m.

Problem 406

Beam loaded as shown in Fig. P-406.

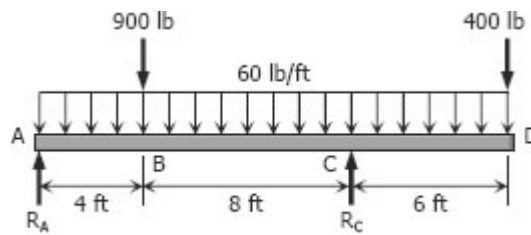

Figure P-406

Solution 406

$$\begin{aligned}\sum M_A &= 0 \\ 12R_C &= 4(900) + 18(400) + 9[(60)(18)] \\ R_C &= 1710 \text{ lb}\end{aligned}$$

$$\begin{aligned}\sum M_C &= 0 \\ 12R_A + 6(400) &= 8(900) + 3[60(18)] \\ R_A &= 670 \text{ lb}\end{aligned}$$

Segment AB:

$$\begin{aligned}V_{AB} &= 670 - 60x \text{ lb} \\ M_{AB} &= 670x - 60x(x/2) \\ &= 670x - 30x^2 \text{ lb-ft}\end{aligned}$$

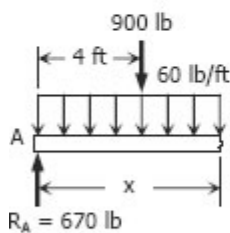
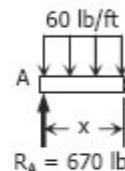

Segment BC:

$$\begin{aligned}V_{BC} &= 670 - 900 - 60x \\ &= -230 - 60x \text{ lb} \\ M_{BC} &= 670x - 900(x - 4) - 60x(x/2) \\ &= 3600 - 230x - 30x^2 \text{ lb-ft}\end{aligned}$$

Segment CD:

$$\begin{aligned}V_{CD} &= 670 + 1710 - 900 - 60x \\ &= 1480 - 60x \text{ lb} \\ M_{CD} &= 670x + 1710(x - 12) \\ &\quad - 900(x - 4) - 60x(x/2) \\ &= -16920 + 1480x - 30x^2 \text{ lb-ft}\end{aligned}$$

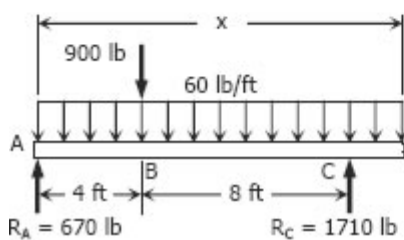

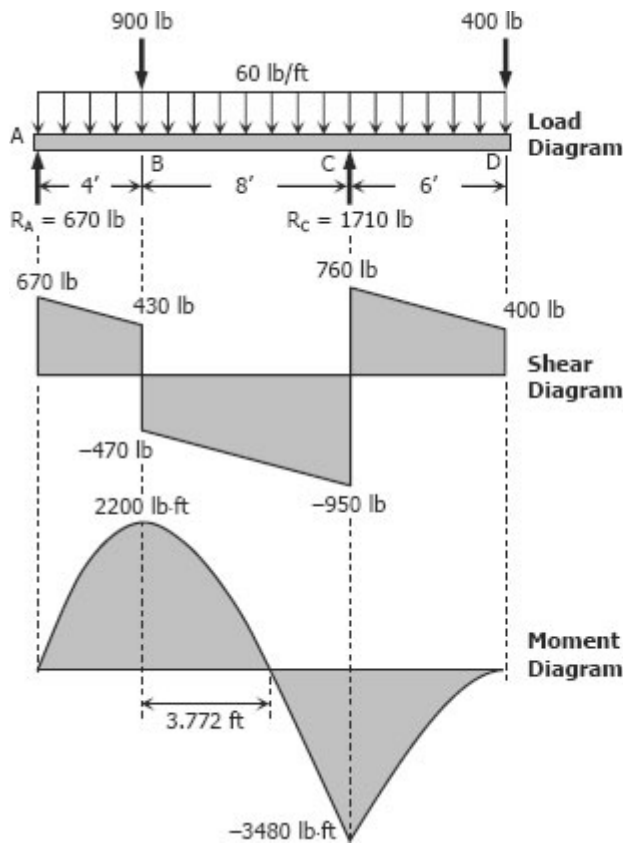

To draw the Shear Diagram:

- (1) $V_{AB} = 670 - 60x$ for segment AB is linear; at $x = 0$, $V_{AB} = 670$ lb; at $x = 4$ ft, $V_{AB} = 430$ lb.
- (2) For segment BC, $V_{BC} = -230 - 60x$ is also linear; at $x = 4$ ft, $V_{BC} = -470$ lb, at $x = 12$ ft, $V_{BC} = -950$ lb.
- (3) $V_{CD} = 1480 - 60x$ for segment CD is again linear; at $x = 12$, $V_{CD} = 760$ lb; at $x = 18$ ft, $V_{CD} = 400$ lb.

To draw the Moment Diagram:

- (1) $M_{AB} = 670x - 30x^2$ for segment AB is a second degree curve; at $x = 0$, $M_{AB} = 0$; at $x = 4$ ft, $M_{AB} = 2200$ lb-ft.
- (2) For BC, $M_{BC} = 3600 - 230x - 30x^2$, is a second degree curve; at $x = 4$ ft, $M_{BC} = 2200$ lb-ft, at $x = 12$ ft, $M_{BC} = -3480$ lb-ft; When $M_{BC} = 0$, $3600 - 230x - 30x^2 = 0$, $x = -15.439$ ft and 7.772 ft. Take $x = 7.772$ ft, thus, the moment is zero at 3.772 ft from B.
- (3) For segment CD, $M_{CD} = -16920 + 1480x - 30x^2$ is a second degree curve; at $x = 12$ ft, $M_{CD} = -3480$ lb-ft; at $x = 18$ ft, $M_{CD} = 0$.

Problem 407

Beam loaded as shown in Fig. P-407.

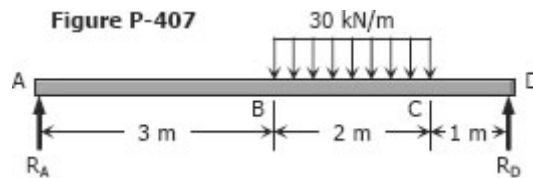

Solution 407

$$\begin{aligned} \sum M_A = 0 \\ 6R_D = 4[2(30)] \\ R_D = 40 \text{ kN} \end{aligned}$$

$$\begin{aligned} \sum M_D = 0 \\ 6R_A = 2[2(30)] \\ R_A = 20 \text{ kN} \end{aligned}$$

Segment AB:
 $V_{AB} = 20 \text{ kN}$
 $M_{AB} = 20x \text{ kN}\cdot\text{m}$

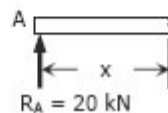

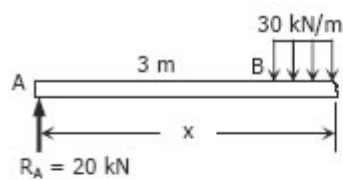

Segment BC:

$$V_{BC} = 20 - 30(x - 3)$$

$$= 110 - 30x \text{ kN}$$

$$M_{BC} = 20x - 30(x - 3)(x - 3)/2$$

$$= 20x - 15(x - 3)^2$$

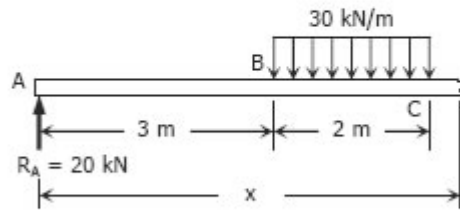

Segment CD:

$$V_{CD} = 20 - 30(2)$$

$$= -40 \text{ kN}$$

$$M_{CD} = 20x - 30(2)(x - 4)$$

$$= 20x - 60(x - 4)$$

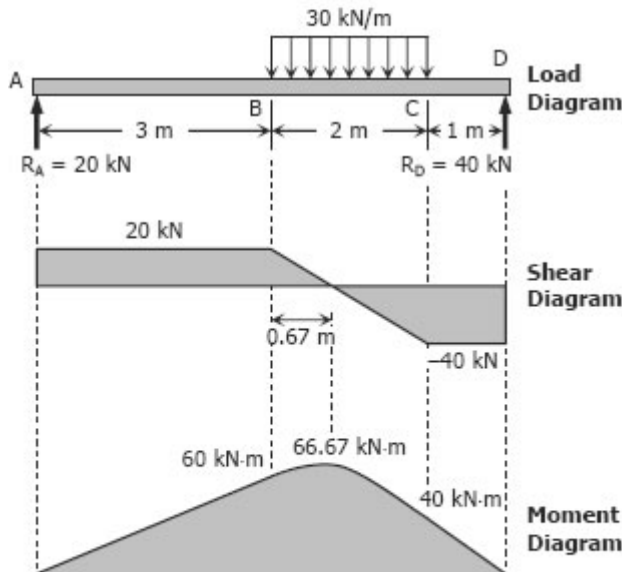

To draw the Shear Diagram:

- (1) For segment AB, the shear is uniformly distributed at 20 kN.
- (2) $V_{BC} = 110 - 30x$ for segment BC; at $x = 3$ m, $V_{BC} = 20$ kN; at $x = 5$ m, $V_{BC} = -40$ kN. For $V_{BC} = 0$, $x = 3.67$ m or 0.67 m from B.
- (3) The shear for segment CD is uniformly distributed at -40 kN.

To draw the Moment Diagram:

- (1) For AB, $M_{AB} = 20x$; at $x = 0$, $M_{AB} = 0$; at $x = 3$ m, $M_{AB} = 60$ kN-m.
- (2) $M_{BC} = 20x - 15(x - 3)^2$ for segment BC is second degree curve; at $x = 3$ m, $M_{BC} = 60$ kN-m; at $x = 5$ m, $M_{BC} = 40$ kN-m. Note that maximum moment occurred at zero shear; at $x = 3.67$ m, $M_{BC} = 66.67$ kN-m.
- (3) $M_{CD} = 20x - 60(x - 4)$ for segment BC is linear; at $x = 5$ m, $M_{CD} = 40$ kN-m; at $x = 6$ m, $M_{CD} = 0$.

Problem 408

Beam loaded as shown in Fig. P-408.

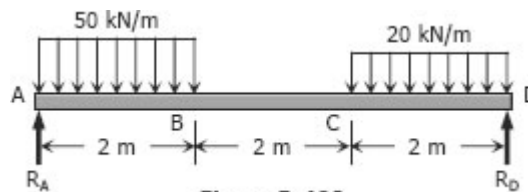
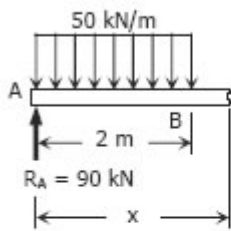

Figure P-408

Solution 408

$$\begin{array}{l|l} \sum M_A = 0 & \sum M_D = 0 \\ 6R_D = 1[2(50)] + 5[2(20)] & 6R_A = 5[2(50)] + 1[2(20)] \\ R_D = 50 \text{ kN} & R_A = 90 \text{ kN} \end{array}$$



Segment AB:

$$V_{AB} = 90 - 50x \text{ kN}$$

$$M_{AB} = 90x - 50x(x/2)$$

$$= 90x - 25x^2$$

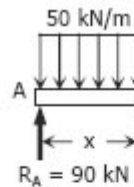

Segment BC:

$$V_{BC} = 90 - 50(2)$$

$$= -10 \text{ kN}$$

$$M_{BC} = 90x - 2(50)(x - 1)$$

$$= -10x + 100 \text{ kN}\cdot\text{m}$$

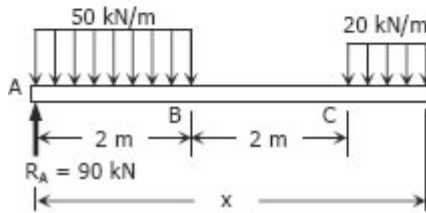

Segment CD:

$$V_{CD} = 90 - 2(50) - 20(x - 4)$$

$$= -20x + 70 \text{ kN}$$

$$M_{CD} = 90x - 2(50)(x - 1)$$

$$- 20(x - 4)(x - 4)/2$$

$$= 90x - 100(x - 1) - 10(x - 4)^2$$

$$= -10x^2 + 70x - 60 \text{ kN}\cdot\text{m}$$

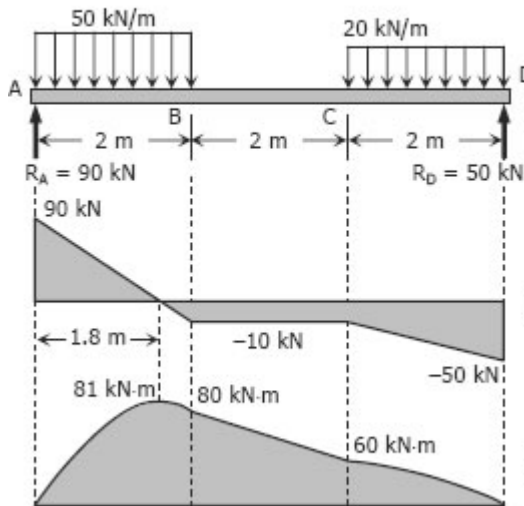

To draw the Shear Diagram:

- (1) $V_{AB} = 90 - 50x$ is linear; at $x = 0$, $V_{BC} = 90 \text{ kN}$; at $x = 2 \text{ m}$, $V_{BC} = -10 \text{ kN}$. When $V_{AB} = 0$, $x = 1.8 \text{ m}$.
- (2) $V_{BC} = -10 \text{ kN}$ along segment BC.
- (3) $V_{CD} = -20x + 70$ is linear; at $x = 4 \text{ m}$, $V_{CD} = -10 \text{ kN}$; at $x = 6 \text{ m}$, $V_{CD} = -50 \text{ kN}$.

To draw the Moment Diagram:

- (1) $M_{AB} = 90x - 25x^2$ is second degree; at $x = 0$, $M_{AB} = 0$; at $x = 1.8 \text{ m}$, $M_{AB} = 81 \text{ kN}\cdot\text{m}$; at $x = 2 \text{ m}$, $M_{AB} = 80 \text{ kN}\cdot\text{m}$.
- (2) $M_{BC} = -10x + 100$ is linear; at $x = 2 \text{ m}$, $M_{BC} = 80 \text{ kN}\cdot\text{m}$; at $x = 4 \text{ m}$, $M_{BC} = 60 \text{ kN}\cdot\text{m}$.
- (3) $M_{CD} = -10x^2 + 70x - 60$; at $x = 4 \text{ m}$, $M_{CD} = 60 \text{ kN}\cdot\text{m}$; at $x = 6 \text{ m}$, $M_{CD} = 0$.

Problem 409

Cantilever beam loaded as shown in Fig. P-409.

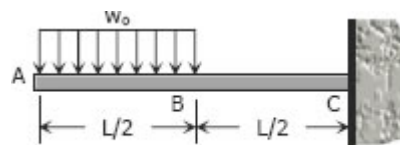

Figure P-409

Solution 409

Segment AB:

$$V_{AB} = -w_0x$$

$$M_{AB} = -w_0x(x/2)$$

$$= -\frac{1}{2}w_0x^2$$

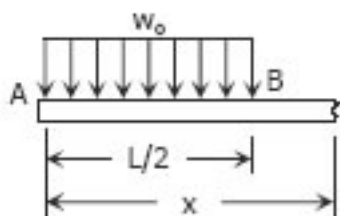
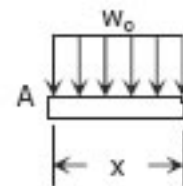

Segment BC:

$$V_{BC} = -w_0(L/2)$$

$$= -\frac{1}{2}w_0L$$

$$M_{BC} = -w_0(L/2)(x - L/4)$$

$$= -\frac{1}{2}w_0Lx + \frac{1}{8}w_0L^2$$

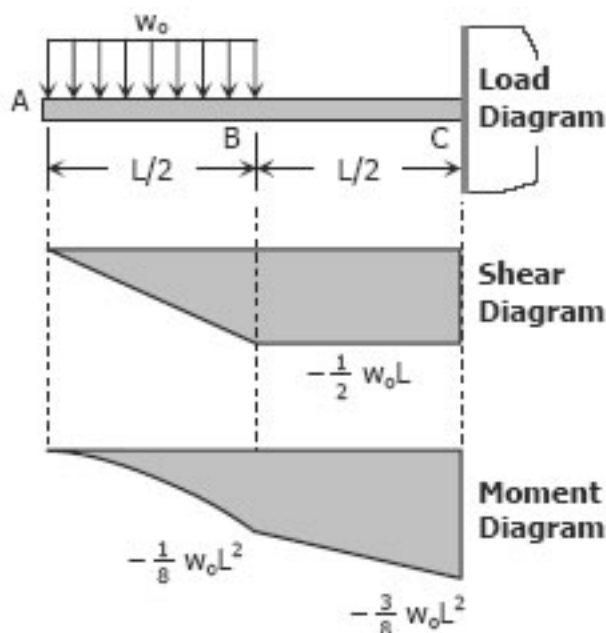

To draw the Shear Diagram:

- (1) $V_{AB} = -w_0x$ for segment AB is linear; at $x = 0$, $V_{AB} = 0$; at $x = L/2$, $V_{AB} = -\frac{1}{2}w_0L$.
- (2) At BC, the shear is uniformly distributed by $-\frac{1}{2}w_0L$.

To draw the Moment Diagram:

- (1) $M_{AB} = -\frac{1}{2}w_0x^2$ is a second degree curve; at $x = 0$, $M_{AB} = 0$; at $x = L/2$, $M_{AB} = -\frac{1}{8}w_0L^2$.
- (2) $M_{BC} = -\frac{1}{2}w_0Lx + \frac{1}{8}w_0L^2$ is a second degree; at $x = L/2$, $M_{BC} = -\frac{1}{8}w_0L^2$; at $x = L$, $M_{BC} = -\frac{3}{8}w_0L^2$.

Problem 410

Cantilever beam carrying the uniformly varying load shown in Fig. P-410.

Figure P-410

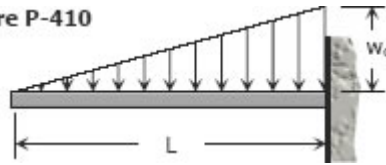

Solution 410

$$\frac{y}{x} = \frac{w_0}{L}$$

$$y = \frac{w_0}{L}x$$

$$F_x = \frac{1}{2}xy$$

$$= \frac{1}{2}x\left(\frac{w_0}{L}x\right)$$

$$= \frac{w_0}{2L}x^2$$

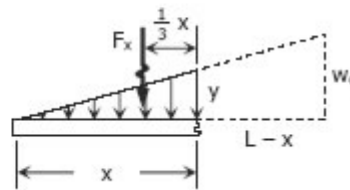

Shear equation:

$$V = -\frac{w_0}{2L}x^2$$

Moment equation:

$$M = -\frac{1}{3}xF_x = -\frac{1}{3}x\left(\frac{w_0}{2L}x^2\right)$$

$$= -\frac{w_0}{6L}x^3$$

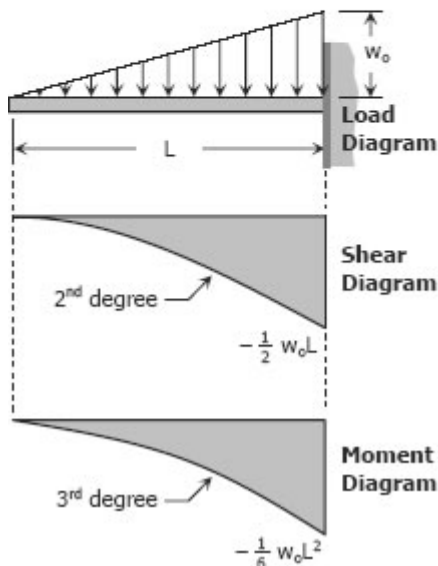

To draw the Shear Diagram:

$V = -\frac{w_0}{2L}x^2$ is a second degree curve;

at $x = 0, V = 0$; at $x = L, V = -\frac{1}{2}w_0L$.

To draw the Moment Diagram:

$M = -\frac{w_0}{6L}x^3$ is a third degree curve; at

$x = 0, M = 0$; at $x = L, M = -\frac{1}{6}w_0L^2$.

Problem 411

Cantilever beam carrying a distributed load with intensity varying from w_0 at the free end to zero at the wall, as shown in Fig. P-411.

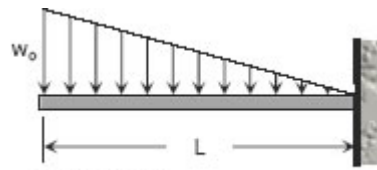
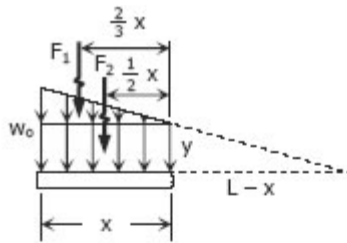

Figure P-411

Solution 411

$$\frac{y}{L-x} = \frac{w_0}{L}$$

$$y = \frac{w_0}{L}(L-x)$$



$$\begin{aligned} F_1 &= \frac{1}{2}x(w_0 - y) \\ &= \frac{1}{2}x \left[w_0 - \frac{w_0}{L}(L-x) \right] \\ &= \frac{1}{2}x \left[w_0 - w_0 + \frac{w_0}{L}x \right] \\ &= \frac{w_0}{2L}x^2 \end{aligned}$$

$$\begin{aligned} F_2 &= xy = x \left[\frac{w_0}{L}(L-x) \right] \\ &= \frac{w_0}{L}(Lx - x^2) \end{aligned}$$

Shear equation:

$$\begin{aligned} V &= -F_1 - F_2 = -\frac{w_0}{2L}x^2 - \frac{w_0}{L}(Lx - x^2) \\ &= -\frac{w_0}{2L}x^2 - w_0x + \frac{w_0}{L}x^2 \\ &= \frac{w_0}{2L}x^2 - w_0x \end{aligned}$$

Moment equation:

$$\begin{aligned} M &= -\frac{2}{3}xF_1 - \frac{1}{2}xF_2 \\ &= -\frac{1}{3}x \left(\frac{w_0}{2L}x^2 \right) - \frac{1}{2}x \left[\frac{w_0}{L}(Lx - x^2) \right] \\ &= -\frac{w_0}{3L}x^3 - \frac{w_0}{2}x^2 + \frac{w_0}{2L}x^3 \\ &= -\frac{w_0}{2}x^2 + \frac{w_0}{6L}x^3 \end{aligned}$$

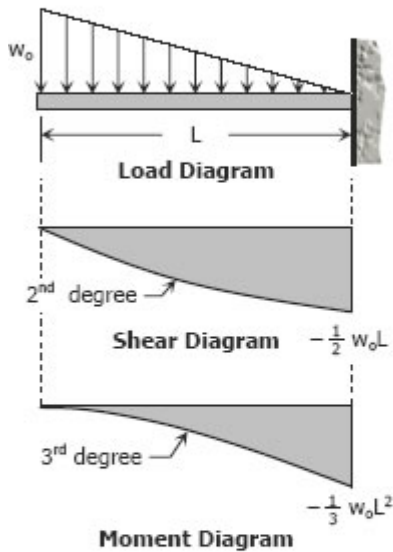

To draw the Shear Diagram:

$V = \frac{w_0}{2L}x^2 - w_0x$ is a concave upward second degree curve; at $x = 0$, $V = 0$; at $x = L$, $V = -\frac{1}{2}w_0L$.

To draw the Moment diagram:

$M = -\frac{w_0}{2}x^2 + \frac{w_0}{6L}x^3$ is in third degree; at $x = 0$, $M = 0$; at $x = L$, $M = -\frac{1}{3}w_0L^2$.

Problem 412

Beam loaded as shown in Fig. P-412.

Figure P-406

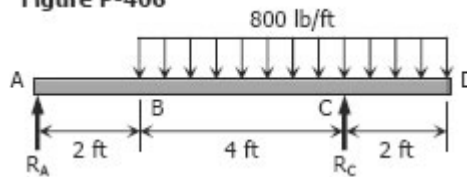

Solution 412

$$\begin{array}{l|l} \sum M_A = 0 & \sum M_C = 0 \\ 6R_C = 5[6(800)] & 6R_A = 1[6(800)] \\ R_C = 4000 \text{ lb} & R_A = 800 \text{ lb} \end{array}$$

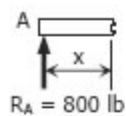

Segment AB:

$$\begin{aligned} V_{AB} &= 800 \text{ lb} \\ M_{AB} &= 800x \end{aligned}$$

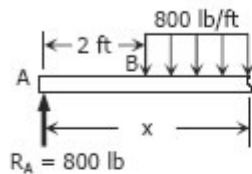

Segment BC:

$$\begin{aligned} V_{BC} &= 800 - 800(x - 2) \\ &= 2400 - 800x \\ M_{BC} &= 800x - 800(x - 2)(x - 2)/2 \\ &= 800x - 400(x - 2)^2 \end{aligned}$$

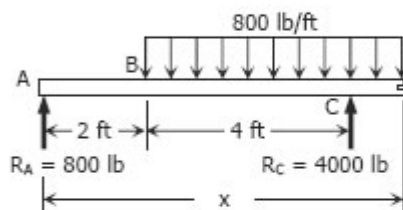

Segment CD:

$$\begin{aligned} V_{CD} &= 800 + 4000 - 800(x - 2) \\ &= 4800 - 800x + 1600 \\ &= 6400 - 800x \\ M_{CD} &= 800x + 4000(x - 6) - 800(x - 2)(x - 2)/2 \\ &= 800x + 4000(x - 6) - 400(x - 2)^2 \end{aligned}$$

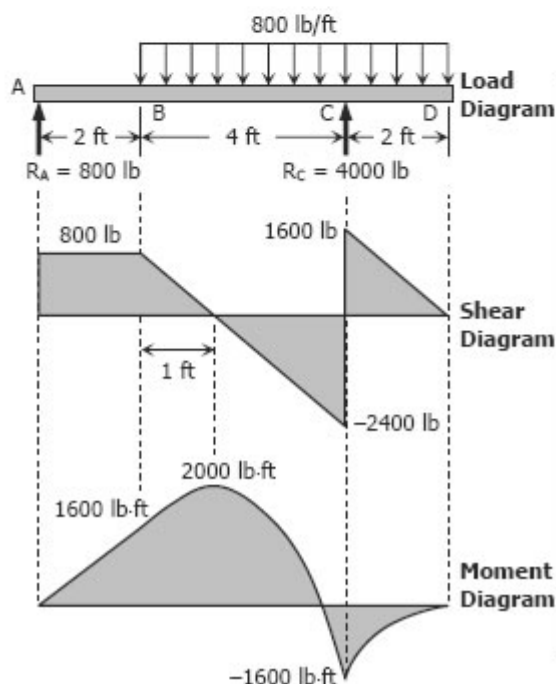

To draw the Shear Diagram:

- 800 lb of shear force is uniformly distributed along segment AB.
- $V_{BC} = 2400 - 800x$ is linear; at $x = 2$ ft, $V_{BC} = 800$ lb; at $x = 6$ ft, $V_{BC} = -2400$ lb. When $V_{BC} = 0$, $2400 - 800x = 0$, thus $x = 3$ ft or $V_{BC} = 0$ at 1 ft from B.
- $V_{CD} = 6400 - 800x$ is also linear; at $x = 6$ ft, $V_{CD} = 1600$ lb; at $x = 8$ ft, $V_{CD} = 0$.

To draw the Moment Diagram:

- $M_{AB} = 800x$ is linear; at $x = 0$, $M_{AB} = 0$; at $x = 2$ ft, $M_{AB} = 1600$ lb-ft.
- $M_{BC} = 800x - 400(x - 2)^2$ is second degree curve; at $x = 2$ ft, $M_{BC} = 1600$ lb-ft; at $x = 6$ ft, $M_{BC} = -1600$ lb-ft; at $x = 3$ ft, $M_{BC} = 2000$ lb-ft.
- $M_{CD} = 800x + 4000(x - 6) - 400(x - 2)^2$ is also a second degree curve; at $x = 6$ ft, $M_{CD} = -1600$ lb-ft; at $x = 8$ ft, $M_{CD} = 0$.

Problem 413

Beam loaded as shown in Fig. P-413.

Figure P-413

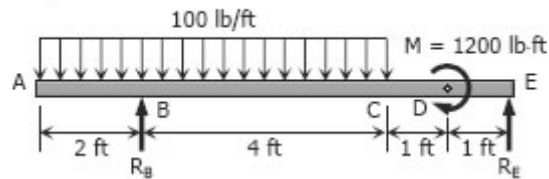

Solution 413

$$\begin{aligned}\sum M_B &= 0 \\ 6R_E &= 1200 + 1[6(100)] \\ R_E &= 300 \text{ lb}\end{aligned}$$

$$\begin{aligned}\sum M_E &= 0 \\ 6R_B + 1200 &= 5[6(100)] \\ R_B &= 300 \text{ lb}\end{aligned}$$

Segment AB:

$$\begin{aligned}V_{AB} &= -100x \text{ lb} \\ M_{AB} &= -100x(x/2) \\ &= -50x^2 \text{ lb}\cdot\text{ft}\end{aligned}$$

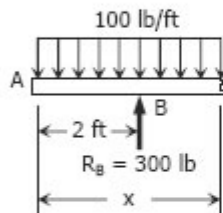
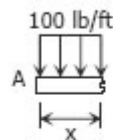

Segment BC:

$$\begin{aligned}V_{BC} &= -100x + 300 \text{ lb} \\ M_{BC} &= -100x(x/2) + 300(x - 2) \\ &= -50x^2 + 300x - 600 \text{ lb}\cdot\text{ft}\end{aligned}$$

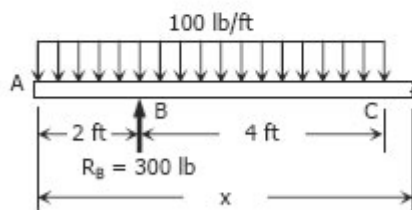

Segment CD:

$$\begin{aligned}V_{CD} &= -100(6) + 300 \\ &= -300 \text{ lb} \\ M_{CD} &= -100(6)(x - 3) + 300(x - 2) \\ &= -600x + 1800 + 300x - 600 \\ &= -300x + 1200 \text{ lb}\cdot\text{ft}\end{aligned}$$

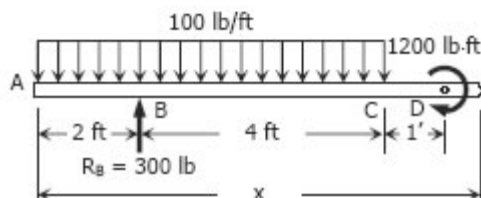

Segment DE:

$$\begin{aligned}V_{DE} &= -100(6) + 300 \\ &= -300 \text{ lb} \\ M_{DE} &= -100(6)(x - 3) + 1200 + 300(x - 2) \\ &= -600x + 1800 + 1200 + 300x - 600 \\ &= -300x + 2400\end{aligned}$$

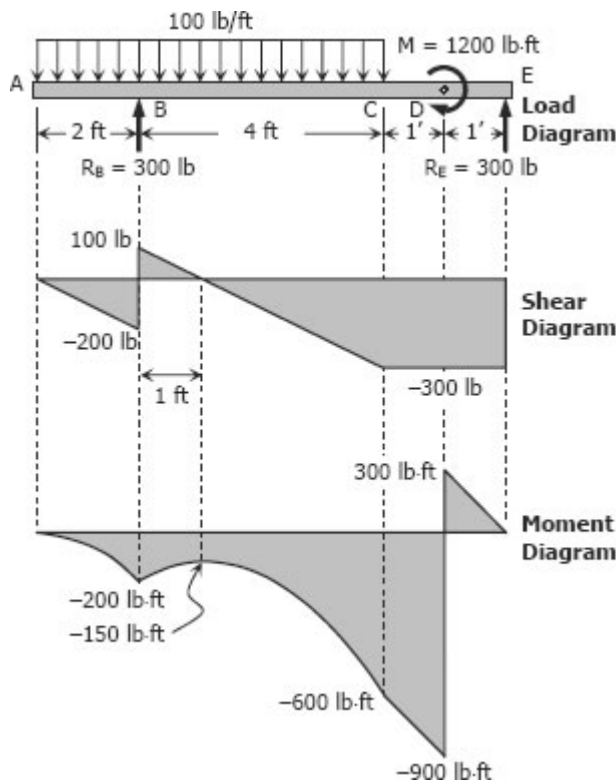

To draw the Shear Diagram:

- (1) $V_{AB} = -100x$ is linear; at $x = 0$, $V_{AB} = 0$; at $x = 2$ ft, $V_{AB} = -200$ lb.
- (2) $V_{BC} = 300 - 100x$ is also linear; at $x = 2$ ft, $V_{BC} = 100$ lb; at $x = 4$ ft, $V_{BC} = -300$ lb. When $V_{BC} = 0$, $x = 3$ ft, or $V_{BC} = 0$ at 1 ft from B.
- (3) The shear is uniformly distributed at -300 lb along segments CD and DE.

To draw the Moment Diagram:

- (1) $M_{AB} = -50x^2$ is a second degree curve; at $x = 0$, $M_{AB} = 0$; at $x = 2$ ft, $M_{AB} = -200$ lb-ft.
- (2) $M_{BC} = -50x^2 + 300x - 600$ is also second degree; at $x = 2$ ft, $M_{BC} = -200$ lb-ft; at $x = 6$ ft, $M_{BC} = -600$ lb-ft; at $x = 3$ ft, $M_{BC} = -150$ lb-ft.
- (3) $M_{CD} = -300x + 1200$ is linear; at $x = 6$ ft, $M_{CD} = -600$ lb-ft; at $x = 7$ ft, $M_{CD} = -900$ lb-ft.
- (4) $M_{DE} = -300x + 2400$ is again linear; at $x = 7$ ft, $M_{DE} = 300$ lb-ft; at $x = 8$ ft, $M_{DE} = 0$.

Problem 414

Cantilever beam carrying the load shown in Fig. P-414.

Figure P-414

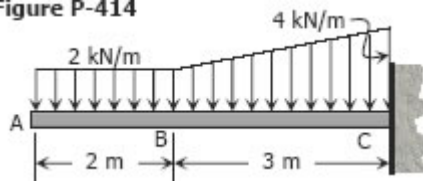

Solution 414

Segment AB:

$$V_{AB} = -2x \text{ kN}$$

$$M_{AB} = -2x(x/2)$$

$$= -x^2 \text{ kN}\cdot\text{m}$$

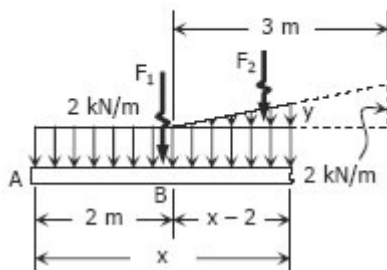
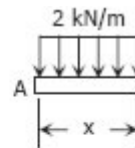

Segment BC:

$$\frac{y}{x-2} = \frac{2}{3}$$

$$y = \frac{2}{3}(x-2)$$

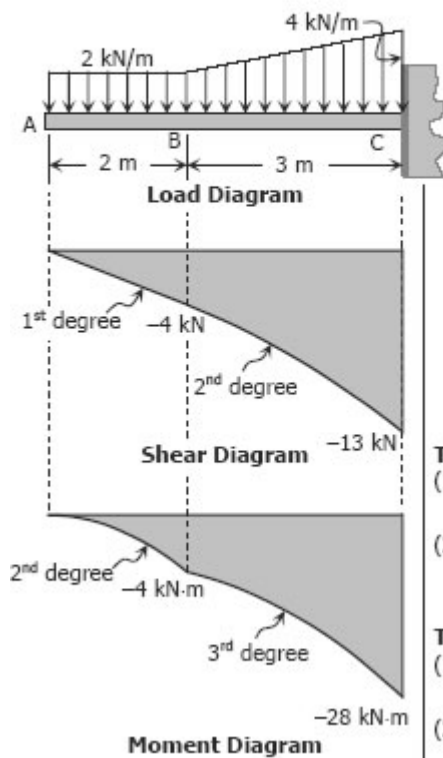

$$F_1 = 2x$$

$$F_2 = \frac{1}{2}(x-2)y$$

$$= \frac{1}{2}(x-2)\left[\frac{2}{3}(x-2)\right]$$

$$= \frac{1}{3}(x-2)^2$$

$$V_{BC} = -F_1 - F_2$$

$$= -2x - \frac{1}{3}(x-2)^2$$

$$M_{BC} = -(x/2)F_1 - \frac{1}{3}(x-2)F_2$$

$$= -(x/2)(2x) - \frac{1}{3}(x-2)\left[\frac{1}{3}(x-2)^2\right]$$

$$= -x^2 - \frac{1}{9}(x-2)^3$$

To draw the Shear Diagram:

- (1) $V_{AB} = -2x$ is linear; at $x = 0$, $V_{AB} = 0$; at $x = 2$ m, $V_{AB} = -4$ kN.
- (2) $V_{BC} = -2x - \frac{1}{3}(x-2)^2$ is a second degree curve; at $x = 2$ m, $V_{BC} = -4$ kN; at $x = 5$ m; $V_{BC} = -13$ kN.

To draw the Moment Diagram:

- (1) $M_{AB} = -x^2$ is a second degree curve; at $x = 0$, $M_{AB} = 0$; at $x = 2$ m, $M_{AB} = -4$ kN-m.
- (2) $M_{BC} = -x^2 - \frac{1}{9}(x-2)^3$ is a third degree curve; at $x = 2$ m, $M_{BC} = -4$ kN-m; at $x = 5$ m, $M_{BC} = -28$ kN-m.

Problem 415

Cantilever beam loaded as shown in Fig. P-415.

Figure P-415

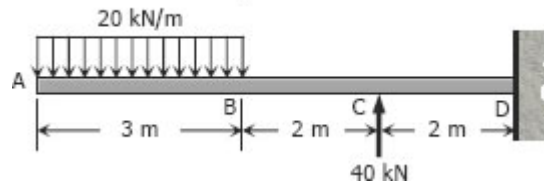

Solution 415

Segment AB:

$$V_{AB} = -20x \text{ kN}$$

$$M_{AB} = -20x(x/2)$$

$$= -10x^2 \text{ kN}\cdot\text{m}$$

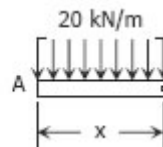

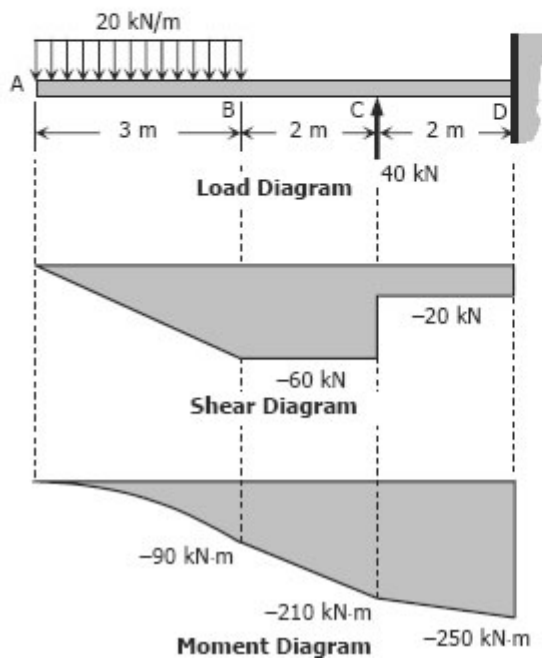
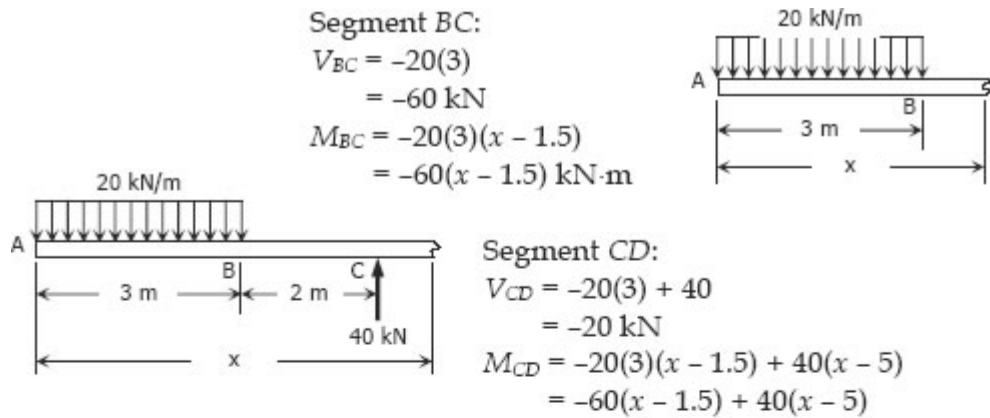

To draw the Shear Diagram

- (1) $V_{AB} = -20x$ for segment AB is linear; at $x = 0, V = 0$; at $x = 3 \text{ m}, V = -60 \text{ kN}$.
- (2) $V_{BC} = -60 \text{ kN}$ is uniformly distributed along segment BC.
- (3) Shear is uniform along segment CD at -20 kN .

To draw the Moment Diagram

- (1) $M_{AB} = -10x^2$ for segment AB is second degree curve; at $x = 0, M_{AB} = 0$; at $x = 3 \text{ m}, M_{AB} = -90 \text{ kN}\cdot\text{m}$.
- (2) $M_{BC} = -60(x - 1.5)$ for segment BC is linear; at $x = 3 \text{ m}, M_{BC} = -90 \text{ kN}\cdot\text{m}$; at $x = 5 \text{ m}, M_{BC} = -210 \text{ kN}\cdot\text{m}$.
- (3) $M_{CD} = -60(x - 1.5) + 40(x - 5)$ for segment CD is also linear; at $x = 5 \text{ m}, M_{CD} = -210 \text{ kN}\cdot\text{m}$, at $x = 7 \text{ m}, M_{CD} = -250 \text{ kN}\cdot\text{m}$.

Problem 416

Beam carrying uniformly varying load shown in Fig. P-416.

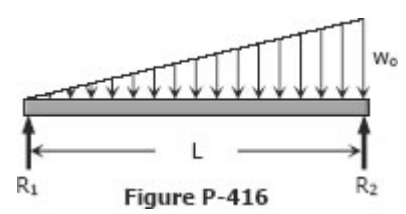

Solution 416

$$\sum M_{R_2} = 0$$

$$LR_1 = \frac{1}{3} LF$$

$$R_1 = \frac{1}{3} \left(\frac{1}{2} Lw_0 \right) \\ = \frac{1}{6} Lw_0$$

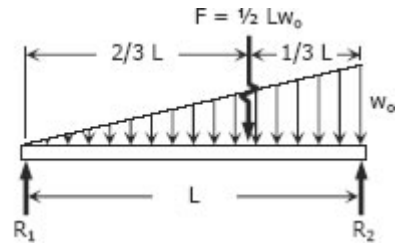

$$\sum M_{R_1} = 0$$

$$LR_2 = \frac{2}{3} LF$$

$$R_2 = \frac{2}{3} \left(\frac{1}{2} Lw_0 \right) \\ = \frac{1}{3} Lw_0$$

$$\frac{y}{x} = \frac{w_0}{L}$$

$$y = \frac{w_0}{L} x$$

$$F_x = \frac{1}{2} xy = \frac{1}{2} x \left(\frac{w_0}{L} x \right) \\ = \frac{w_0}{2L} x^2$$

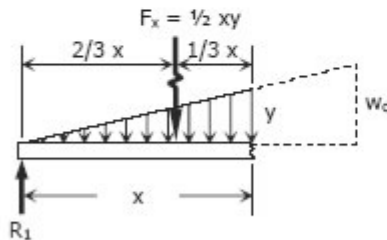

$$V = R_1 - F_x$$

$$= \frac{1}{6} Lw_0 - \frac{w_0}{2L} x^2$$

$$M = R_1 x - F_x \left(\frac{1}{3} x \right)$$

$$= \frac{1}{6} Lw_0 x - \frac{w_0}{2L} x^2 \left(\frac{1}{3} x \right)$$

$$= \frac{1}{6} Lw_0 x - \frac{w_0}{6L} x^3$$

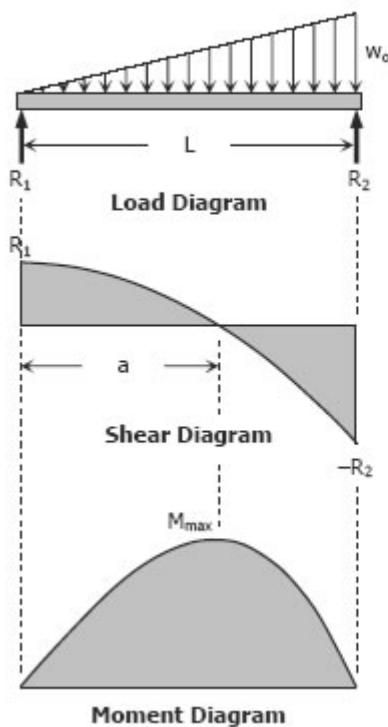

To draw the Shear Diagram:

$V = 1/6 Lw_0 - w_0 x^2/2L$ is a second degree curve; at $x = 0$, $V = 1/6 Lw_0 = R_1$; at $x = L$, $V = -1/3 Lw_0 = -R_2$; If a is the location of zero shear from left end, $0 = 1/6 Lw_0 - w_0 x^2/2L$, $x = 0.5774L = a$; to check, use the squared property of parabola:

$$a^2/R_1 = L^2/(R_1 + R_2)$$

$$a^2/(1/6 Lw_0) = L^2/(1/6 Lw_0 + 1/3 Lw_0)$$

$$a^2 = (1/6 L^3 w_0)/(1/2 Lw_0) = 1/3 L^2$$

$$a = 0.5774L \quad a =$$

To draw the Moment Diagram

$M = 1/6 Lw_0 x - w_0 x^3/6L$ is a third degree curve; at $x = 0$, $M = 0$; at $x = L$, $M = 0$; at $x = a = 0.5774L$, $M = M_{max}$

$$M_{max} = 1/6 Lw_0(0.5774L) - w_0(0.5774L)^3/6L$$

$$M_{max} = 0.0962L^2 w_0 - 0.0321L^2 w_0$$

$$M_{max} = 0.0641L^2 w_0$$

Problem 417

Beam carrying the triangular loading shown in Fig. P- 417.

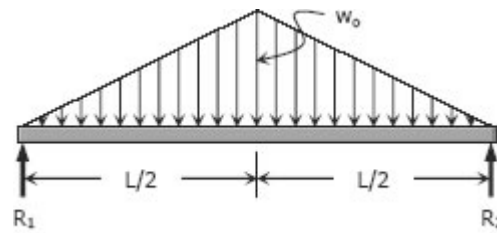

Figure P-417

Solution 417

By symmetry:

$$R_1 = R_2 = \frac{1}{2} \left(\frac{1}{2} L w_0 \right) = \frac{1}{4} L w_0$$

$$\frac{y}{x} = \frac{w_0}{L/2}; \quad y = \frac{2w_0}{L} x$$

$$F = \frac{1}{2} xy = \frac{1}{2} x \left(\frac{2w_0}{L} x \right)$$

$$F = \frac{w_0}{L} x^2$$

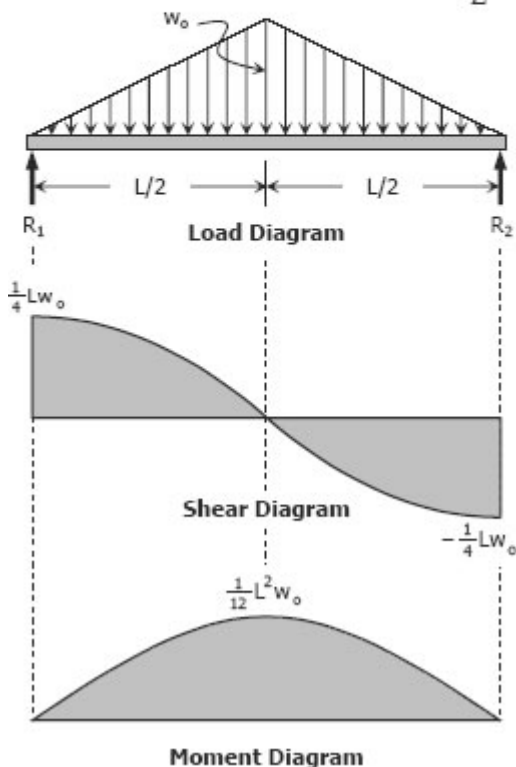
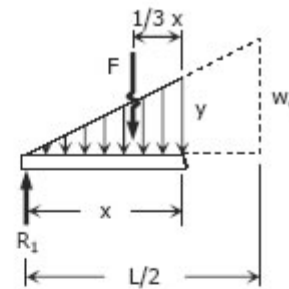

$$V = R_1 - F$$

$$V = \frac{1}{4} L w_0 - \frac{w_0}{L} x^2$$

$$M = R_1 x - F \left(\frac{1}{3} x \right)$$

$$M = \frac{1}{4} L w_0 x - \left(\frac{w_0}{L} x^2 \right) \left(\frac{1}{3} x \right)$$

$$M = \frac{1}{4} L w_0 x - \frac{w_0}{3L} x^3$$

To draw the Shear Diagram:

$V = Lw_0/4 - w_0x^2/L$ is a second degree curve; at $x = 0$, $V = Lw_0/4$; at $x = L/2$, $V = 0$. The other half of the diagram can be drawn by the concept of symmetry.

To draw the Moment Diagram

$M = Lw_0x/4 - w_0x^3/3L$ is a third degree curve; at $x = 0$, $M = 0$; at $x = L/2$, $M = L^2w_0/12$. The other half of the diagram can be drawn by the concept of symmetry.

Problem 418

Cantilever beam loaded as shown in Fig. P-418.

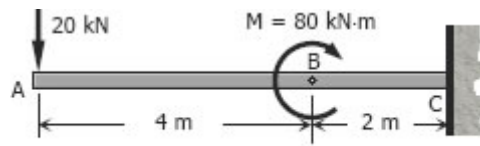
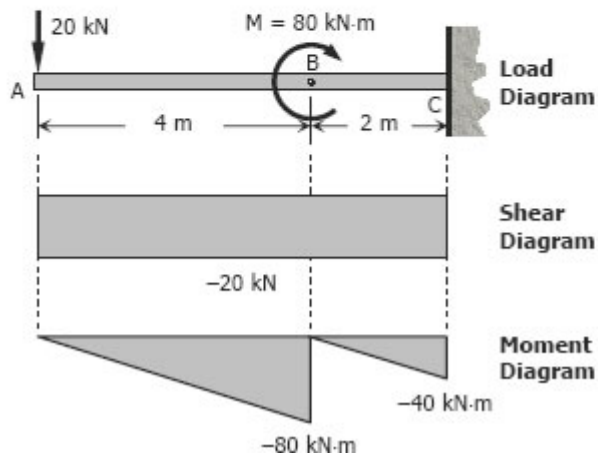
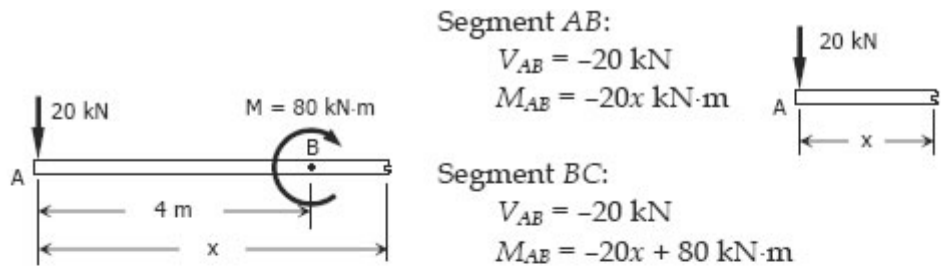

Figure P-418

Solution 418



To draw the Shear Diagram:
 V_{AB} and V_{BC} are equal and constant at -20 kN .

To draw the Moment Diagram:
 (1) $M_{AB} = -20x$ is linear; when $x = 0$, $M_{AB} = 0$; when $x = 4 \text{ m}$, $M_{AB} = -80 \text{ kN}\cdot\text{m}$.
 (2) $M_{BC} = -20x + 80$ is also linear; when $x = 4 \text{ m}$, $M_{BC} = 0$; when $x = 6 \text{ m}$, $M_{BC} = -40 \text{ kN}\cdot\text{m}$

Problem 419

Beam loaded as shown in Fig. P-419.

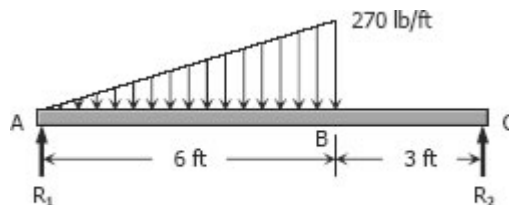
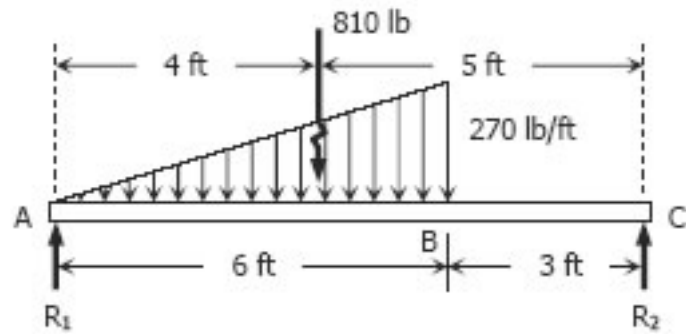

Figure P-419

Solution 419



$$[\sum M_C = 0] \quad 9R_1 = 5(810)$$

$$R_1 = 450 \text{ lb}$$

$$[\sum M_A = 0] \quad 9R_2 = 4(810)$$

$$R_2 = 360 \text{ lb}$$

Segment AB:

$$\frac{y}{x} = \frac{270}{6}$$

$$y = 45x$$

$$F = \frac{1}{2}xy = \frac{1}{2}x(45x)$$

$$F = 22.5x^2$$

$$V_{AB} = R_1 - F$$

$$= 450 - 22.5x^2 \text{ lb}$$

$$M_{AB} = R_1x - F\left(\frac{1}{3}x\right)$$

$$= 450x - 22.5x^2\left(\frac{1}{3}x\right)$$

$$= 450x - 7.5x^3 \text{ lb-ft}$$

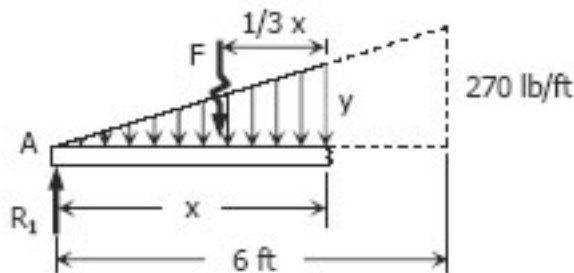

Segment BC:

$$V_{BC} = 450 - 810$$

$$= -360 \text{ lb}$$

$$M_{BC} = 450x - 810(x - 4)$$

$$= 450x - 810x + 3240$$

$$= 3240 - 360x \text{ lb-ft}$$

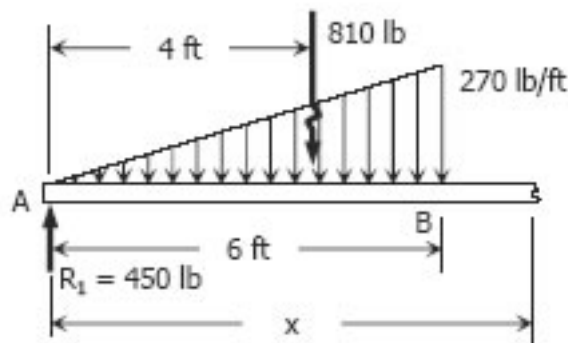

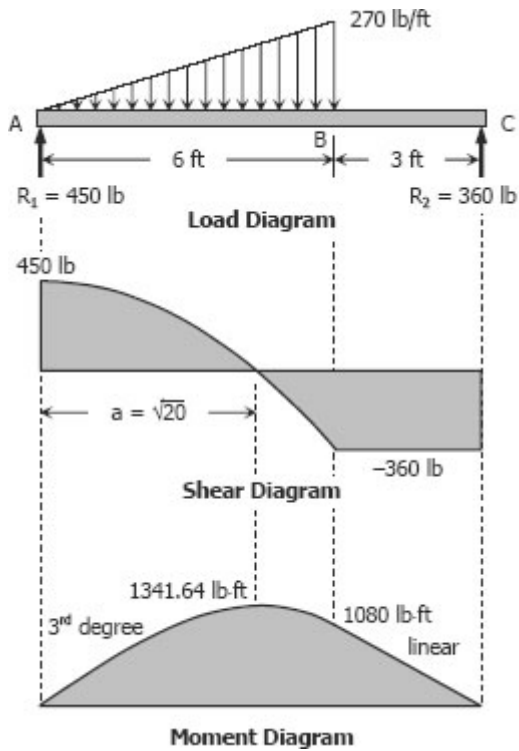

To draw the Shear Diagram:

- (1) $V_{AB} = 450 - 22.5x^2$ is a second degree curve; at $x = 0$, $V_{AB} = 450$ lb; at $x = 6$ ft, $V_{AB} = -360$ lb.
- (2) At $x = a$, $V_{AB} = 0$,
 $450 - 22.5x^2 = 0$
 $22.5x^2 = 450$
 $x^2 = 20$
 $x = \sqrt{20}$

To check, use the squared property of parabola.

$$\frac{a^2}{450} = \frac{6^2}{(450 + 360)}$$

$$a^2 = 20$$

$$a = \sqrt{20}$$

- (3) $V_{BC} = -360$ lb is constant.

To draw the Moment Diagram:

- (1) $M_{AB} = 450x - 7.5x^3$ for segment AB is third degree curve; at $x = 0$, $M_{AB} = 0$; at $x = \sqrt{20}$, $M_{AB} = 1341.64$ lb-ft; at $x = 6$ ft, $M_{AB} = 1080$ lb-ft.
- (2) $M_{BC} = 3240 - 360x$ for segment BC is linear; at $x = 6$ ft, $M_{BC} = 1080$ lb-ft; at $x = 9$ ft, $M_{BC} = 0$.

Problem 420

A total distributed load of 30 kips supported by a uniformly distributed reaction as shown in Fig. P-420.

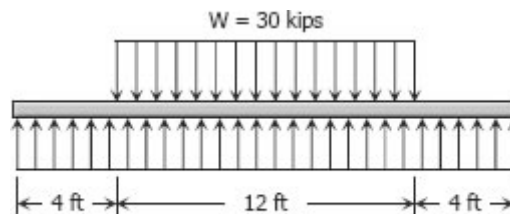
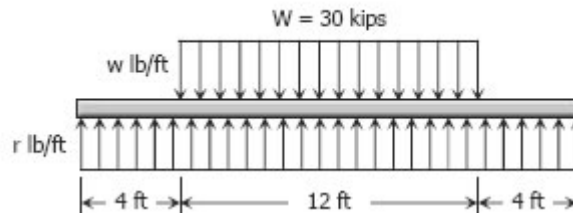

Figure P-420

Solution 420



$$w = 30(1000)/12$$

$$w = 2500 \text{ lb/ft}$$

$$\sum F_v = 0$$

$$R = W$$

$$20r = 30(1000)$$

$$r = 1500 \text{ lb/ft}$$

First segment (from 0 to 4 ft from left):

$$V_1 = 1500x$$

$$M_1 = 1500x(x/2)$$

$$= 750x^2$$

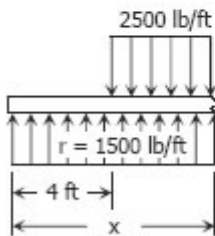
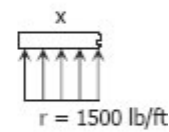

Second segment (from 4 ft to mid-span):

$$V_2 = 1500x - 2500(x - 4)$$

$$= 10000 - 1000x$$

$$M_2 = 1500x(x/2) - 2500(x - 4)(x - 4)/2$$

$$= 750x^2 - 1250(x - 4)^2$$

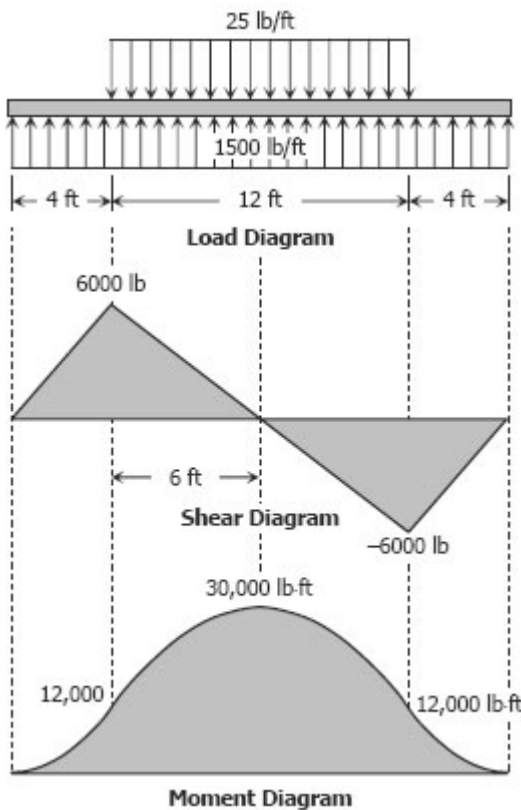

To draw the Shear Diagram:

- (1) For the first segment, $V_1 = 1500x$ is linear; at $x = 0$, $V_1 = 0$; at $x = 4$ ft, $V_1 = 6000$ lb.
- (2) For the second segment, $V_2 = 10000 - 1000x$ is also linear; at $x = 4$ ft, $V_2 = 6000$ lb; at mid-span, $x = 10$ ft, $V_2 = 0$.
- (3) For the next half of the beam, the shear diagram can be accomplished by the concept of symmetry.

To draw the Moment Diagram:

- (1) For the first segment, $M_1 = 750x^2$ is a second degree curve, an open upward parabola; at $x = 0$, $M_1 = 0$; at $x = 4$ ft, $M_1 = 12000$ lb-ft.
- (2) For the second segment, $M_2 = 750x^2 - 1250(x - 4)^2$ is a second degree curve, an downward parabola; at $x = 4$ ft, $M_2 = 12000$ lb-ft; at mid-span, $x = 10$ ft, $M_2 = 30000$ lb-ft.
- (2) The next half of the diagram, from $x = 10$ ft to $x = 20$ ft, can be drawn by using the concept of symmetry.

Problem 421

Write the shear and moment equations as functions of the angle θ for the built-in arch shown in Fig. P-421.

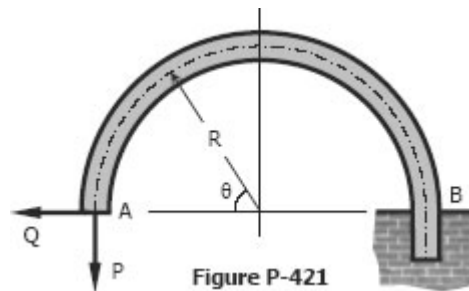

Solution 421

For θ that is less than 90°

Components of Q and P :

$$Q_x = Q \sin \theta$$

$$Q_y = Q \cos \theta$$

$$P_x = P \sin (90^\circ - \theta)$$

$$= P (\sin 90^\circ \cos \theta - \cancel{\cos 90^\circ \sin \theta})$$

$$= P \cos \theta$$

$$P_y = P \cos (90^\circ - \theta)$$

$$= P (\cancel{\cos 90^\circ \cos \theta} + \sin 90^\circ \sin \theta)$$

$$= P \sin \theta$$

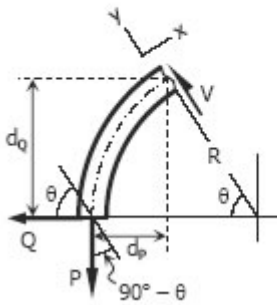

Shear:

$$V = \sum F_y$$

$$V = Q_y - P_y$$

$$V = Q \cos \theta - P \sin \theta$$

Moment arms:

$$d_Q = R \sin \theta$$

$$d_P = R - R \cos \theta$$

$$= R (1 - \cos \theta)$$

Moment:

$$M = \sum M_{\text{counterclockwise}} - \sum M_{\text{clockwise}}$$

$$M = Q(d_Q) - P(d_P)$$

$$M = QR \sin \theta - PR(1 - \cos \theta)$$

For θ that is greater than 90°

Components of Q and P :

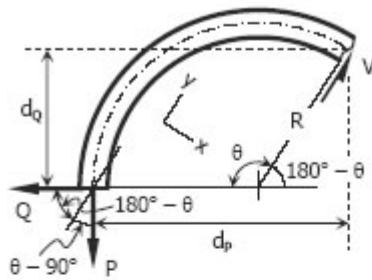

$$\begin{aligned} Q_x &= Q \sin (180^\circ - \theta) \\ &= Q (\sin 180^\circ \cos \theta - \cos 180^\circ \sin \theta) \\ &= Q \cos \theta \end{aligned}$$

$$\begin{aligned} Q_y &= Q \cos (180^\circ - \theta) \\ &= Q (\cos 180^\circ \cos \theta + \sin 180^\circ \sin \theta) \\ &= -Q \sin \theta \end{aligned}$$

$$\begin{aligned} P_x &= P \sin (\theta - 90^\circ) \\ &= P (\sin \theta \cos 90^\circ - \cos \theta \sin 90^\circ) \\ &= -P \cos \theta \end{aligned}$$

$$\begin{aligned} P_y &= P \cos (\theta - 90^\circ) \\ &= P (\cos \theta \cos 90^\circ + \sin \theta \sin 90^\circ) \\ &= P \sin \theta \end{aligned}$$

Shear:

$$\begin{aligned} V &= \sum F_y \\ V &= -Q_y - P_y \\ V &= -(-Q \sin \theta) - P \sin \theta \\ V &= Q \sin \theta - P \sin \theta \end{aligned}$$

Moment arms:

$$\begin{aligned} d_Q &= R \sin (180^\circ - \theta) \\ &= R (\sin 180^\circ \cos \theta - \cos 180^\circ \sin \theta) \\ &= R \sin \theta \end{aligned}$$

$$\begin{aligned} d_P &= R + R \cos (180^\circ - \theta) \\ &= R + R (\cos 180^\circ \cos \theta + \sin 180^\circ \sin \theta) \\ &= R - R \cos \theta \\ &= R(1 - \cos \theta) \end{aligned}$$

Moment:

$$\begin{aligned} M &= \sum M_{\text{counterclockwise}} - \sum M_{\text{clockwise}} \\ M &= Q(d_Q) - P(d_P) \\ M &= QR \sin \theta - PR(1 - \cos \theta) \end{aligned}$$

Problem 422

Write the shear and moment equations for the semicircular arch as shown in Fig. P-422 if (a) the load P is vertical as shown, and (b) the load is applied horizontally to the left at the top of the arch.

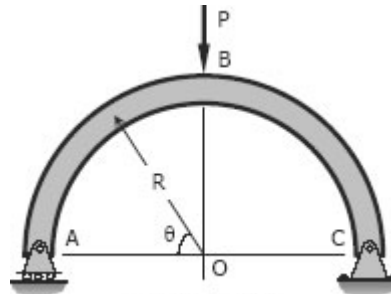
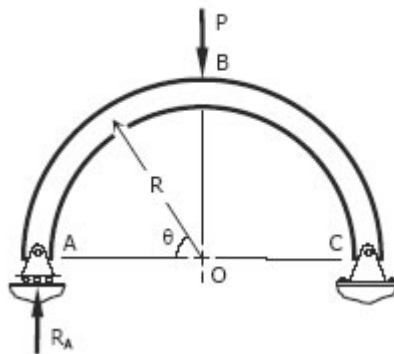

Figure P-422

Solution 422



$$\begin{aligned} \sum M_C &= 0 \\ 2R(R_A) &= RP \\ R_A &= \frac{1}{2}P \end{aligned}$$

For θ that is less than 90°

Shear:

$$\begin{aligned} V_{AB} &= R_A \cos(90^\circ - \theta) \\ V_{AB} &= \frac{1}{2}P (\cos 90^\circ \cos \theta + \sin 90^\circ \sin \theta) \\ V_{AB} &= \frac{1}{2}P \sin \theta \end{aligned}$$

Moment arm:

$$\begin{aligned} d &= R - R \cos \theta \\ d &= R(1 - \cos \theta) \end{aligned}$$

Moment:

$$\begin{aligned} M_{AB} &= R_s(d) \\ M_{AB} &= \frac{1}{2}PR(1 - \cos \theta) \end{aligned}$$

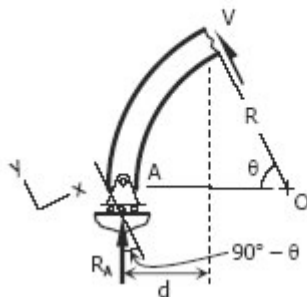

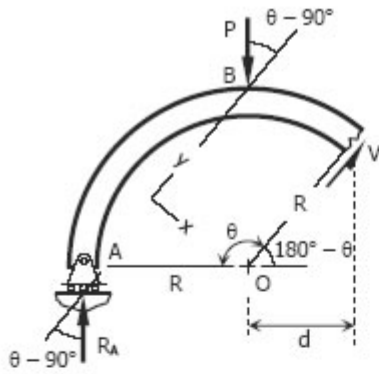

For θ that is greater than 90°

Components of P and R_A :

$$\begin{aligned} P_x &= P \sin(\theta - 90^\circ) \\ &= P(\sin \theta \cos 90^\circ - \cos \theta \sin 90^\circ) \\ &= -P \cos \theta \end{aligned}$$

$$\begin{aligned} P_y &= P \cos(\theta - 90^\circ) \\ &= P(\cos \theta \cos 90^\circ + \sin \theta \sin 90^\circ) \\ &= P \sin \theta \end{aligned}$$

$$\begin{aligned} R_{Ax} &= R_A \sin(\theta - 90^\circ) \\ &= \frac{1}{2} P(\sin \theta \cos 90^\circ - \cos \theta \sin 90^\circ) \\ &= -\frac{1}{2} P \cos \theta \end{aligned}$$

$$\begin{aligned} R_{Ay} &= R_A \cos(\theta - 90^\circ) \\ &= \frac{1}{2} P(\cos \theta \cos 90^\circ + \sin \theta \sin 90^\circ) \\ &= \frac{1}{2} P \sin \theta \end{aligned}$$

Shear:

$$V_{BC} = \sum F_y$$

$$V_{BC} = R_{Ay} - P_y$$

$$V_{BC} = \frac{1}{2} P \sin \theta - P \sin \theta$$

$$V_{BC} = -\frac{1}{2} P \sin \theta$$

Moment arm:

$$d = R \cos(180^\circ - \theta)$$

$$d = R(\cos 180^\circ \cos \theta + \sin 180^\circ \sin \theta)$$

$$d = -R \cos \theta$$

Moment:

$$M_{BC} = \sum M_{\text{counterclockwise}} - \sum M_{\text{clockwise}}$$

$$M_{BC} = R_A(R + d) - Pd$$

$$M_{BC} = \frac{1}{2} P(R - R \cos \theta) - P(-R \cos \theta)$$

$$M_{BC} = \frac{1}{2} PR - \frac{1}{2} PR \cos \theta + PR \cos \theta$$

$$M_{BC} = \frac{1}{2} PR + \frac{1}{2} PR \cos \theta$$

$$M_{BC} = \frac{1}{2} PR(1 + \cos \theta)$$

Relationship between Load, Shear, and Moment

The vertical shear at C in the figure shown in previous section is taken as

$$V_C = (\Sigma F_v)_L = R_1 - wx$$

where $R_1 = R_2 = wL/2$

$$V_C = \frac{wL}{2} - wx$$
$$M_C = (\Sigma M_C) = \frac{wL}{2}x - wx\left(\frac{x}{2}\right)$$
$$M_C = \frac{wLx}{2} - \frac{wx^2}{2}$$

If we differentiate M with respect to x:

$$\frac{dM}{dx} = \frac{wL}{2} \frac{dx}{dx} - \frac{w}{2} 2x \frac{dx}{dx}$$
$$\frac{dM}{dx} = \frac{wL}{2} - wx = \text{shear}$$

thus,

$$\frac{dM}{dx} = V$$

Thus, the rate of change of the bending moment with respect to x is equal to the shearing force, or **the slope of the moment diagram at the given point is the shear at that point.**

Differentiate V with respect to x gives

$$\frac{dV}{dx} = 0 - w = \text{load}$$
$$\frac{dV}{dx} = \text{Load}$$

Thus, the rate of change of the shearing force with respect to x is equal to the load or **the slope of the shear diagram at a given point equals the load at that point.**

PROPERTIES OF SHEAR AND MOMENT DIAGRAMS

The following are some important properties of shear and moment diagrams:

1. The area of the shear diagram to the left or to the right of the section is equal to the moment at that section.
2. The slope of the moment diagram at a given point is the shear at that point.
3. The slope of the shear diagram at a given point equals the load at that point.

4. The maximum moment occurs at the point of zero shears.

This is in reference to property number 2, that when the shear (also the slope of the moment diagram) is zero, the tangent drawn to the moment diagram is horizontal.

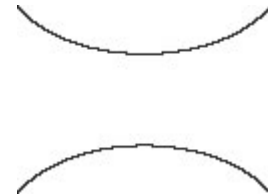

5. When the shear diagram is increasing, the moment diagram is concave upward.

6. When the shear diagram is decreasing, the moment diagram is concave downward.

SIGN CONVENTIONS

The customary sign conventions for shearing force and bending moment are represented by the figures below. A force that tends to bend the beam downward is said to produce a positive bending moment. A force that tends to shear the left portion of the beam upward with respect to the right portion is said to produce a positive shearing force.

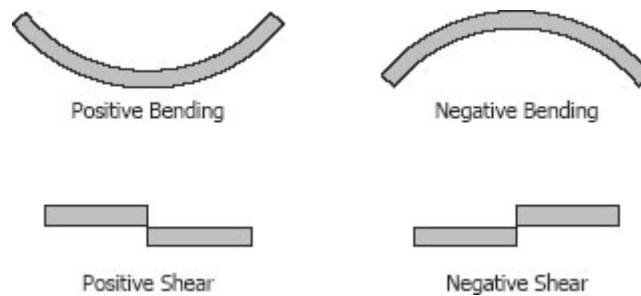

An easier way of determining the sign of the bending moment at any section is that upward forces always cause positive bending moments regardless of whether they act to the left or to the right of the exploratory section.

Solved Problems in Relationship between Load, Shear, and Moment

INSTRUCTION

Without writing shear and moment equations, draw the shear and moment diagrams for the beams specified in the following problems. Give numerical values at all change of loading positions and at all points of zero shear. (Note to instructor: Problems 403 to 420 may also be assigned for solution by semi graphical method describes in this article.)

Problem 425

Beam loaded as shown in Fig. P-425.

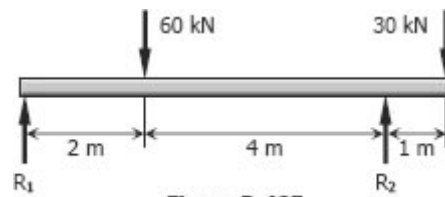
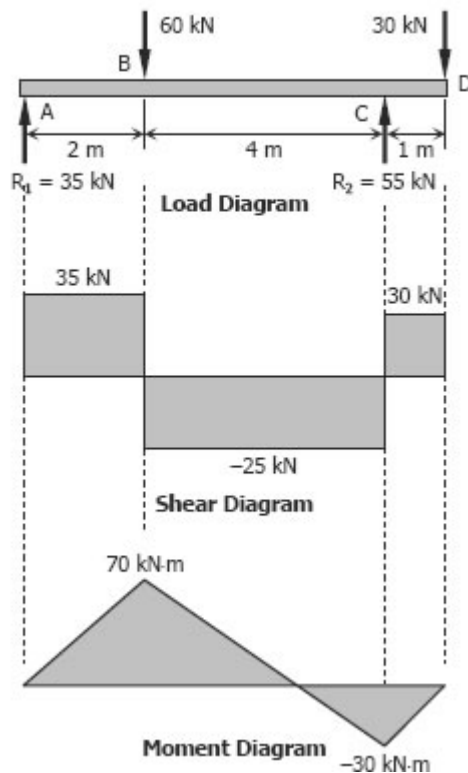

Figure P-425

Solution 425



$$\sum M_A = 0$$

$$6R_2 = 2(60) + 7(30)$$

$$R_2 = 55 \text{ kN}$$

$$\sum M_C = 0$$

$$6R_1 + 1(30) = 4(60)$$

$$R_1 = 35 \text{ kN}$$

To draw the Shear Diagram:

- (1) $V_A = R_1 = 35 \text{ kN}$
- (2) $V_B = V_A + \text{Area in load diagram} - 60 \text{ kN}$
 $V_B = 35 + 0 - 60 = -25 \text{ kN}$
- (3) $V_C = V_B + \text{area in load diagram} + R_2$
 $V_C = -25 + 0 + 55 = 30 \text{ kN}$
- (4) $V_D = V_C + \text{Area in load diagram} - 30 \text{ kN}$
 $V_D = 30 + 0 - 30 = 0$

To draw the Moment Diagram:

- (1) $M_A = 0$
- (2) $M_B = M_A + \text{Area in shear diagram}$
 $M_B = 0 + 35(2) = 70 \text{ kN-m}$
- (3) $M_C = M_B + \text{Area in shear diagram}$
 $M_C = 70 - 25(4) = -30 \text{ kN-m}$
- (4) $M_D = M_C + \text{Area in shear diagram}$
 $M_D = -30 + 30(1) = 0$

Problem 426

Cantilever beam acted upon by a uniformly distributed load and a couple as shown in Fig. P-426.

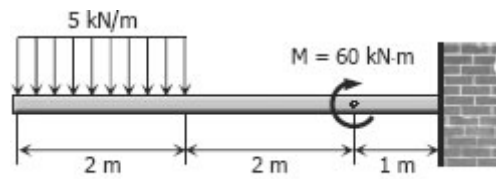
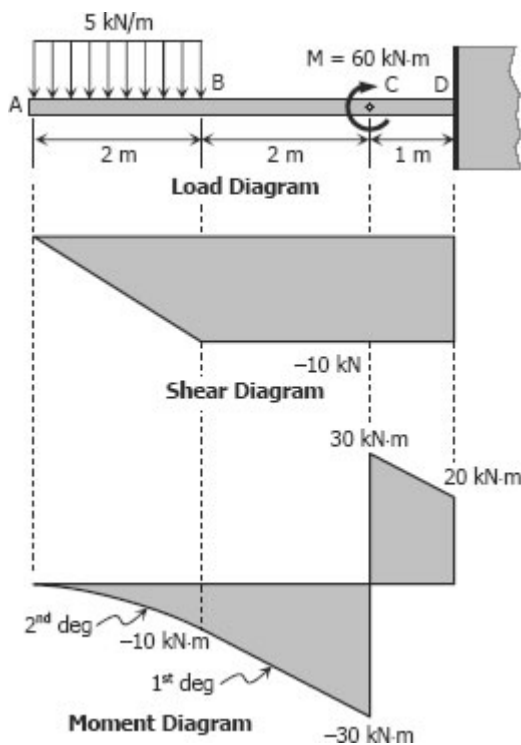

Figure P-426

Solution 426



To draw the Shear Diagram

- (1) $V_A = 0$
- (2) $V_B = V_A + \text{Area in load diagram}$
 $V_B = 0 - 5(2)$
 $V_B = -10 \text{ kN}$
- (3) $V_C = V_B + \text{Area in load diagram}$
 $V_C = -10 + 0$
 $V_C = -10 \text{ kN}$
- (4) $V_D = V_C + \text{Area in load diagram}$
 $V_D = -10 + 0$
 $V_D = -10 \text{ kN}$

To draw the Moment Diagram

- (1) $M_A = 0$
- (2) $M_B = M_A + \text{Area in shear diagram}$
 $M_B = 0 - \frac{1}{2}(2)(10)$
 $M_B = -10 \text{ kN-m}$
- (3) $M_C = M_B + \text{Area in shear diagram}$
 $M_C = -10 - 10(2)$
 $M_C = -30 \text{ kN-m}$
 $M_{C2} = -30 + M = -30 + 60 = 30 \text{ kN-m}$
- (4) $M_D = M_{C2} + \text{Area in shear diagram}$
 $M_D = 30 - 10(1)$
 $M_D = 20 \text{ kN-m}$

Problem 427

Beam loaded as shown in Fig. P-427.

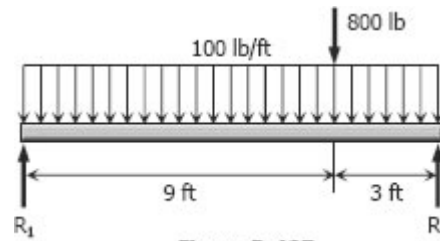
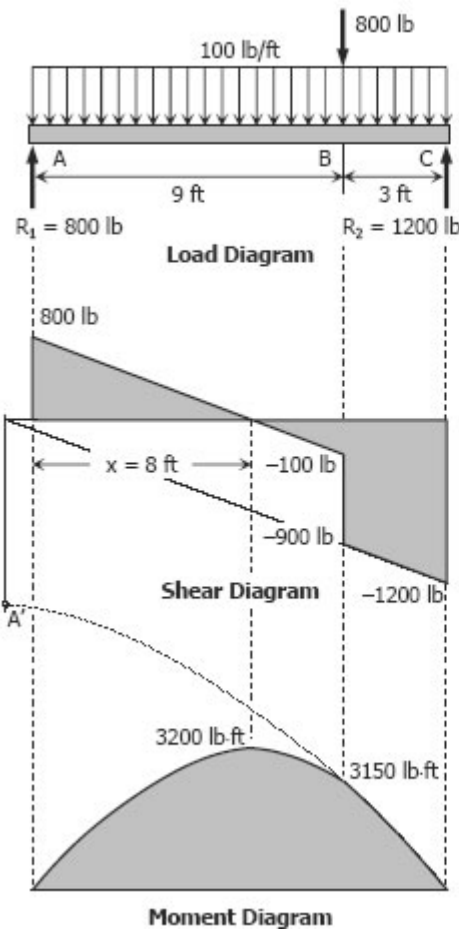

Figure P-427

Solution 427



$$\begin{aligned} \sum M_C &= 0 \\ 12R_1 &= 100(12)(6) + 800(3) \\ R_1 &= 800 \text{ lb} \end{aligned}$$

$$\begin{aligned} \sum M_A &= 0 \\ 12R_2 &= 100(12)(6) + 800(9) \\ R_2 &= 1200 \text{ lb} \end{aligned}$$

To draw the Shear Diagram

- (1) $V_A = R_1 = 800 \text{ lb}$
- (2) $V_B = V_A + \text{Area in load diagram}$
 $V_B = 800 - 100(9)$
 $V_B = -100 \text{ lb}$
 $V_{B2} = -100 - 800 = -900 \text{ lb}$
- (3) $V_C = V_{B2} + \text{Area in load diagram}$
 $V_C = -900 - 100(3)$
 $V_C = -1200 \text{ lb}$
- (4) Solving for x :
 $x / 800 = (9 - x) / 100$
 $100x = 7200 - 800x$
 $x = 8 \text{ ft}$

To draw the Moment Diagram

- (1) $M_A = 0$
- (2) $M_x = M_A + \text{Area in shear diagram}$
 $M_x = 0 + \frac{1}{2}(8)(800) = 3200 \text{ lb-ft}$
- (3) $M_B = M_x + \text{Area in shear diagram}$
 $M_B = 3200 - \frac{1}{2}(1)(100) = 3150 \text{ lb-ft}$
- (4) $M_C = M_B + \text{Area in shear diagram}$
 $M_C = 3150 - \frac{1}{2}(900 + 1200)(3) = 0$
- (5) The moment curve BC is downward parabola with vertex at A'. A' is the location of zero shear for segment BC.

Problem 428

Beam loaded as shown in Fig. P-428.

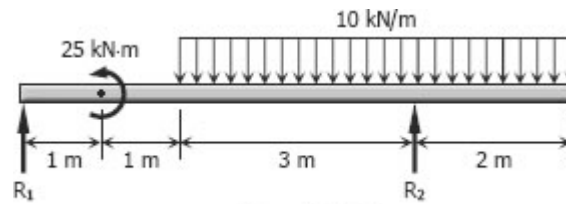
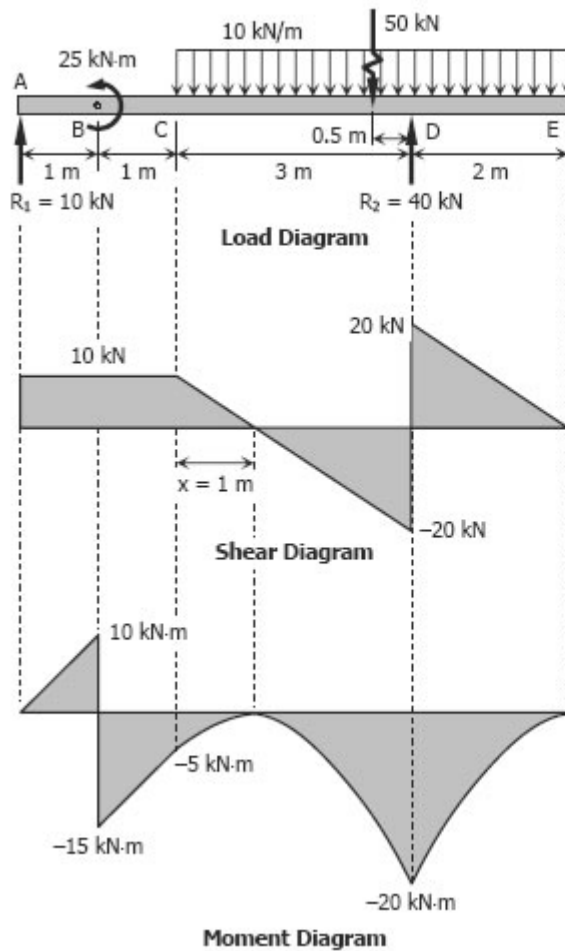

Figure P-428

Solution 428



$$\begin{aligned}\Sigma M_D &= 0 \\ 5R_1 &= 50(0.5) + 25 \\ R_1 &= 10 \text{ kN}\end{aligned}$$

$$\begin{aligned}\Sigma M_A &= 0 \\ 5R_2 + 25 &= 50(4.5) \\ R_2 &= 40 \text{ kN}\end{aligned}$$

To draw the Shear Diagram

- (1) $V_A = R_1 = 10 \text{ kN}$
- (2) $V_B = V_A + \text{Area in load diagram}$
 $V_B = 10 + 0 = 10 \text{ kN}$
- (3) $V_C = V_B + \text{Area in load diagram}$
 $V_C = 10 + 0 = 10 \text{ kN}$
- (4) $V_D = V_C + \text{Area in load diagram}$
 $V_D = 10 - 10(3) = -20 \text{ kN}$
 $V_{D2} = -20 + R_2 = 20 \text{ kN}$
- (5) $V_E = V_{D2} + \text{Area in load diagram}$
 $V_E = 20 - 10(2) = 0$
- (6) Solving for x :
 $x / 10 = (3 - x) / 20$
 $20x = 30 - 10x$
 $x = 1 \text{ m}$

To draw the Moment Diagram

- (1) $M_A = 0$
- (2) $M_B = M_A + \text{Area in shear diagram}$
 $M_B = 0 + 1(10) = 10 \text{ kN-m}$
 $M_{B2} = 10 - 25 = -15 \text{ kN-m}$
- (3) $M_C = M_{B2} + \text{Area in shear diagram}$
 $M_C = -15 + 1(10) = -5 \text{ kN-m}$
- (4) $M_x = M_C + \text{Area in shear diagram}$
 $M_x = -5 + \frac{1}{2}(1)(10) = 0$
- (5) $M_D = M_x + \text{Area in shear diagram}$
 $M_D = 0 - \frac{1}{2}(2)(20) = -20 \text{ kN-m}$
- (6) $M_E = M_D + \text{Area in shear diagram}$
 $M_E = -20 + \frac{1}{2}(2)(20) = 0$

Problem 429

Beam loaded as shown in Fig. P-429.

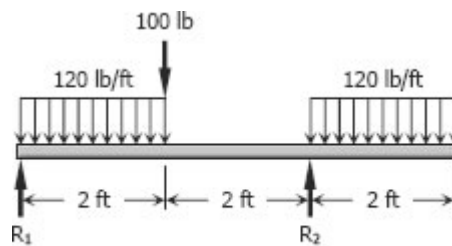
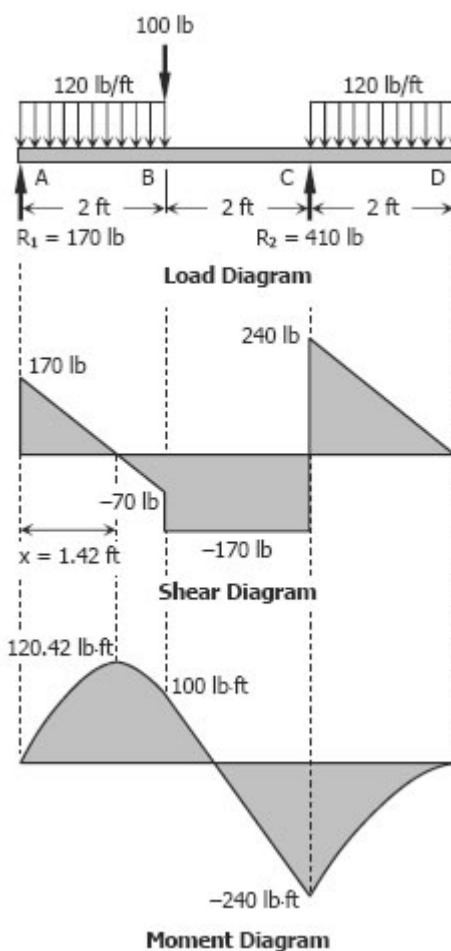

Figure P-429

Solution 429



$$\sum M_C = 0$$

$$4R_1 + 120(2)(1) = 100(2) + 120(2)(3)$$

$$R_1 = 170 \text{ lb}$$

$$\sum M_A = 0$$

$$4R_2 = 120(2)(1) + 100(2) + 120(2)(5)$$

$$R_2 = 410 \text{ lb}$$

To draw the Shear Diagram

$$(1) V_A = R_1 = 170 \text{ lb}$$

$$(2) V_B = V_A + \text{Area in load diagram}$$

$$V_B = 170 - 120(2) = -70 \text{ lb}$$

$$V_{B2} = -70 - 100 = -170 \text{ lb}$$

$$(3) V_C = V_{B2} + \text{Area in load diagram}$$

$$V_C = -170 + 0 = -170 \text{ lb}$$

$$V_{C2} = -170 + R_2$$

$$V_{C2} = -170 + 410 = 240 \text{ lb}$$

$$(4) V_D = V_{C2} + \text{Area in load diagram}$$

$$V_D = 240 - 120(2) = 0$$

$$(5) \text{ Solving for } x:$$

$$x / 170 = (2 - x) / 70$$

$$70x = 340 - 170x$$

$$x = 17 / 12 \text{ ft} = 1.42 \text{ ft}$$

To draw the Moment Diagram

$$(1) M_A = 0$$

$$(2) M_x = M_A + \text{Area in shear diagram}$$

$$M_x = 0 + \frac{1}{2} (17/12)(170)$$

$$M_x = 1445/12 = 120.42 \text{ lb-ft}$$

$$(3) M_B = M_x + \text{Area in shear diagram}$$

$$M_B = 1445/12 - \frac{1}{2} (2 - 17/12)(70)$$

$$M_B = 100 \text{ lb-ft}$$

$$(4) M_C = M_B + \text{Area in shear diagram}$$

$$M_C = 100 - 170(2) = -240 \text{ lb-ft}$$

$$(5) M_D = M_C + \text{Area in shear diagram}$$

$$M_D = -240 + \frac{1}{2} (2)(240) = 0$$

Problem 430

Beam loaded as shown in P-430.

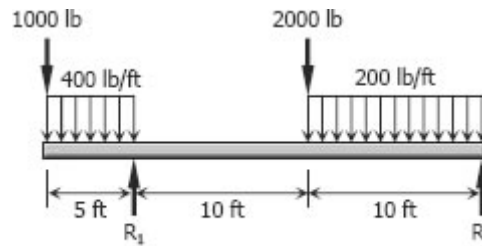
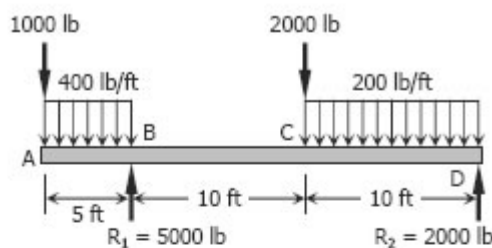
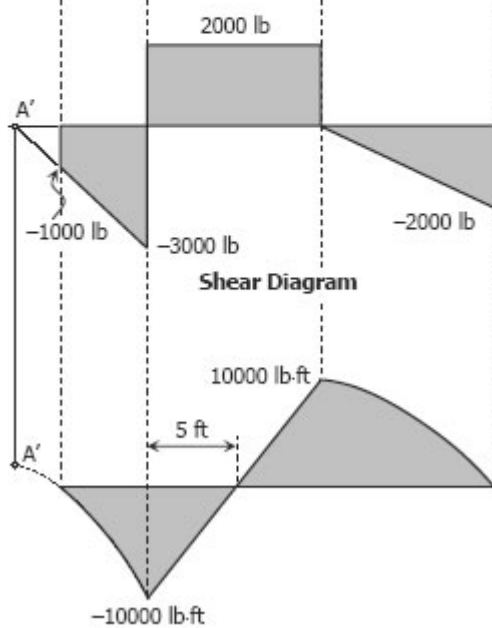

Figure P-430

Solution 430



Load Diagram



Moment Diagram

$$\sum M_D = 0$$

$$20R_1 = 1000(25) + 400(5)(22.5) + 2000(10) + 200(10)(5)$$

$$R_1 = 5000 \text{ lb}$$

$$\sum M_B = 0$$

$$20R_2 + 1000(5) + 400(5)(2.5) = 2000(10) + 200(10)(15)$$

$$R_2 = 2000 \text{ lb}$$

To draw the Shear Diagram

- (1) $V_A = -1000 \text{ lb}$
- (2) $V_B = V_A + \text{Area in load diagram}$
 $V_B = -1000 - 400(5) = -3000 \text{ lb}$
 $V_{B2} = -3000 + R_1 = 2000 \text{ lb}$
- (3) $V_C = V_{B2} + \text{Area in load diagram}$
 $V_C = 2000 + 0 = 2000 \text{ lb}$
 $V_{C2} = 2000 - 2000 = 0$
- (4) $V_D = V_{C2} + \text{Area in load diagram}$
 $V_D = 0 + 200(10) = 2000 \text{ lb}$

To draw the Moment Diagram

- (1) $M_A = 0$
- (2) $M_B = M_A + \text{Area in shear diagram}$
 $M_B = 0 - \frac{1}{2}(1000 + 3000)(5)$
 $M_B = -10000 \text{ lb-ft}$
- (3) $M_C = M_B + \text{Area in shear diagram}$
 $M_C = -10000 + 2000(10) = 10000 \text{ lb-ft}$
- (4) $M_D = M_C + \text{Area in shear diagram}$
 $M_D = 10000 - \frac{1}{2}(10)(2000) = 0$
- (5) For segment BC, the location of zero moment can be accomplished by symmetry and that is 5 ft from B.
- (6) The moment curve AB is a downward parabola with vertex at A'. A' is the location of zero shear for segment AB at point outside the beam.

Problem 431

Beam loaded as shown in Fig. P-431.

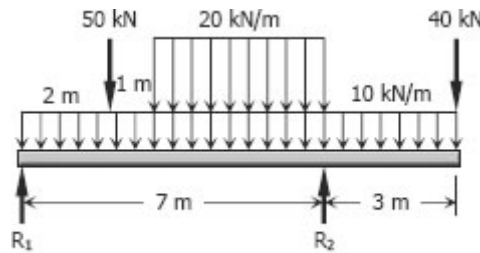
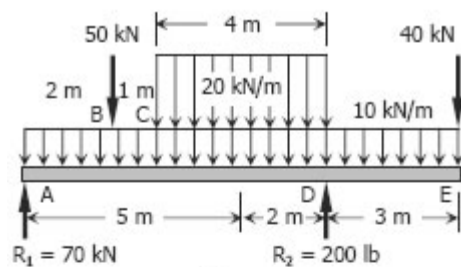

Figure P-431

Solution 431



$$\begin{aligned} \sum M_D = 0 \\ 7R_1 + 40(3) &= 5(50) + 10(10)(2) \\ &\quad + 20(4)(2) \end{aligned}$$

$$R_1 = 70 \text{ kN}$$

$$\begin{aligned} \sum M_A = 0 \\ 7R_2 &= 50(2) + 10(10)(5) + 20(4)(5) \\ &\quad + 40(10) \end{aligned}$$

$$R_2 = 200 \text{ lb}$$

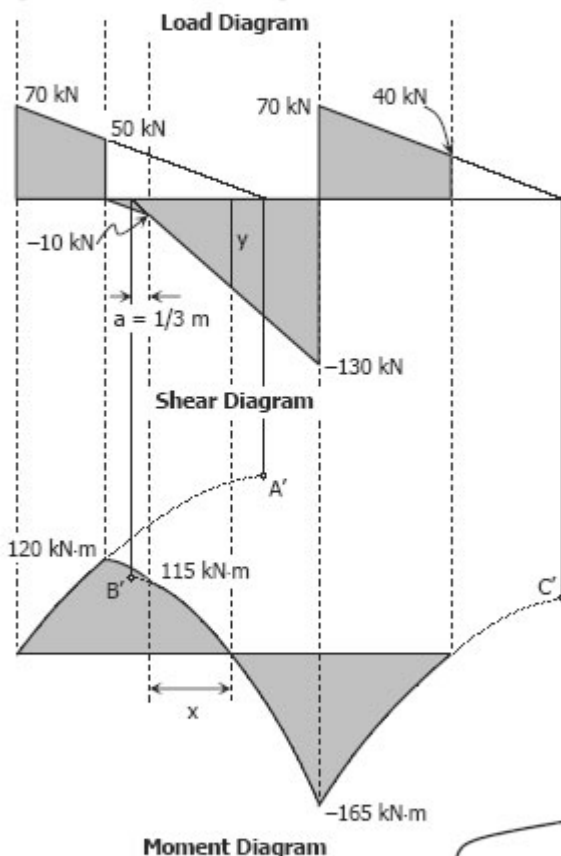

To draw the Shear Diagram

- (1) $V_A = R_1 = 70 \text{ kN}$
- (2) $V_B = V_A + \text{Area in load diagram}$
 $V_B = 70 - 10(2) = 50 \text{ kN}$
 $V_{B2} = 50 - 50 = 0$
- (3) $V_C = V_{B2} + \text{Area in load diagram}$
 $V_C = 0 - 10(1) = -10 \text{ kN}$
- (4) $V_D = V_C + \text{Area in load diagram}$
 $V_D = -10 - 30(4) = -130 \text{ kN}$
 $V_{D2} = -130 + R_2$
 $V_{D2} = -130 + 200 = 70 \text{ kN}$
- (5) $V_E = V_{D2} + \text{Area in load diagram}$
 $V_E = 70 - 10(3) = 40 \text{ kN}$
 $V_{E2} = 40 - 40 = 0$

To draw the Moment Diagram

- (1) $M_A = 0$
- (2) $M_B = M_A + \text{Area in shear diagram}$
 $M_B = 0 + \frac{1}{2}(70 + 50)(2) = 120 \text{ kN-m}$
- (3) $M_C = M_B + \text{Area in shear diagram}$
 $M_C = 120 - \frac{1}{2}(1)(10) = 115 \text{ kN-m}$
- (4) $M_D = M_C + \text{Area in shear diagram}$
 $M_D = 115 - \frac{1}{2}(10 + 130)(4)$
 $M_D = -165 \text{ kN-m}$
- (5) $M_E = M_D + \text{Area in shear diagram}$
 $M_E = -165 + \frac{1}{2}(70 + 40)(3) = 0$
- (6) Moment curves AB, CD and DE are downward parabolas with vertices at A', B' and C', respectively. A', B' and C' are corresponding zero shear points of segments AB, CD and DE.

- (7) Solving for point of zero moment:

$$\begin{aligned} a / 10 &= (a + 4) / 130 \\ 130a &= 10a + 40 \\ a &= 1/3 \text{ m} \end{aligned}$$

$$\begin{aligned} y / (x + a) &= 130 / (4 + a) \\ y &= 130(x + 1/3) / (4 + 1/3) \\ y &= 30x + 10 \end{aligned}$$

$$\begin{aligned} M_C &= 115 \text{ kN-m} \\ M_{\text{zero}} &= M_C + \text{Area in shear} \\ 0 &= 115 - \frac{1}{2}(10 + y)x \\ (10 + y)x &= 230 \\ (10 + 30x + 10)x &= 230 \\ 30x^2 + 20x - 230 &= 0 \\ 3x^2 + 2x - 23 &= 0 \\ x &= 2.46 \text{ m} \\ \text{zero moment is at } &2.46 \text{ m from C} \end{aligned}$$

Another way to solve the location of zero moment is by the squared property of parabola (see Problem 434). This point is the appropriate location for construction joint of concrete structures.

Problem 432

Beam loaded as shown in Fig. P-432.

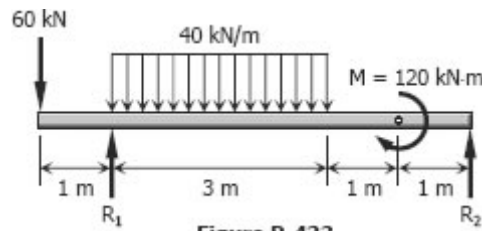
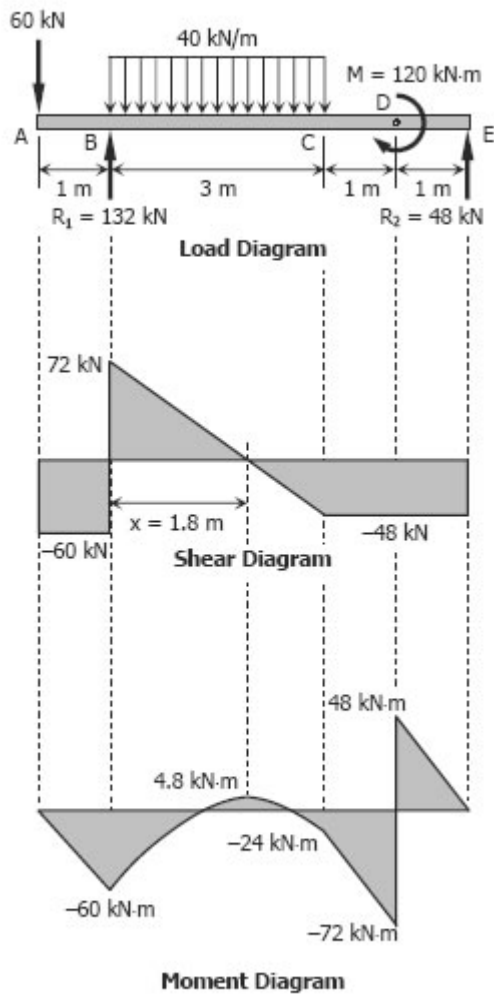

Figure P-432

Solution 432



$$\sum M_E = 0$$

$$5R_1 + 120 = 6(60) + 40(3)(3.5)$$

$$R_1 = 132 \text{ kN}$$

$$\sum M_B = 0$$

$$5R_2 + 60(1) = 40(3)(1.5) + 120$$

$$R_2 = 48 \text{ kN}$$

To draw the Shear Diagram

- (1) $V_A = -60 \text{ kN}$
- (2) $V_B = V_A + \text{Area in load diagram}$
 $V_B = -60 + 0 = -60 \text{ kN}$
 $V_{B2} = V_B + R_1 = -60 + 132 = 72 \text{ kN}$
- (3) $V_C = V_{B2} + \text{Area in load diagram}$
 $V_C = 72 - 3(40) = -48 \text{ kN}$
- (4) $V_D = V_C + \text{Area in load diagram}$
 $V_D = -48 + 0 = -48 \text{ kN}$
- (5) $V_E = V_D + \text{Area in load diagram}$
 $V_E = -48 + 0 = -48 \text{ kN}$
 $V_{E2} = V_E + R_2 = -48 + 48 = 0$
- (6) Solving for x :
 $x / 72 = (3 - x) / 48$
 $48x = 216 - 72x$
 $x = 1.8 \text{ m}$

To draw the Moment Diagram

- (1) $M_A = 0$
- (2) $M_B = M_A + \text{Area in shear diagram}$
 $M_B = 0 - 60(1) = -60 \text{ kN-m}$
- (3) $M_x = M_B + \text{Area in shear diagram}$
 $M_x = -60 + \frac{1}{2}(1.8)(72) = 4.8 \text{ kN-m}$
- (4) $M_C = M_x + \text{Area in shear diagram}$
 $M_C = 4.8 - \frac{1}{2}(3 - 1.8)(48) = -24 \text{ kN-m}$
- (5) $M_D = M_C + \text{Area in shear diagram}$
 $M_D = -24 - \frac{1}{2}(24 + 72)(1) = -72 \text{ kN-m}$
 $M_{D2} = -72 + 120 = 48 \text{ kN-m}$
- (6) $M_E = M_{D2} + \text{Area in shear diagram}$
 $M_E = 48 - 48(1) = 0$
- (7) The location of zero moment on segment BC can be determined using the squared property of parabola. See the solution of Problem 434.

Problem 433

Overhang beam loaded by a force and a couple as shown in Fig. P-433.

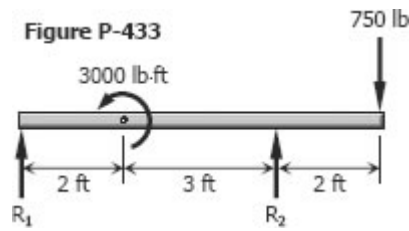

Solution 433

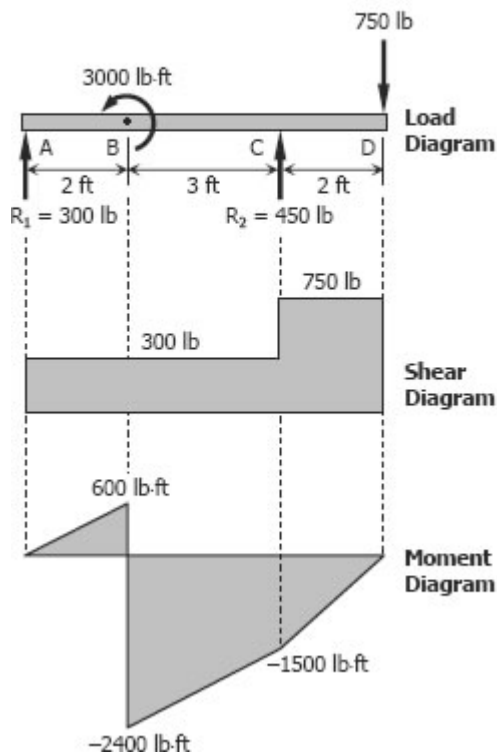

$$\begin{aligned}\sum M_C &= 0 \\ 5R_1 + 2(750) &= 3000 \\ R_1 &= 300 \text{ lb}\end{aligned}$$

$$\begin{aligned}\sum M_A &= 0 \\ 5R_2 + 3000 &= 7(750) \\ R_2 &= 450 \text{ lb}\end{aligned}$$

To draw the Shear Diagram

- (1) $V_A = R_1 = 300 \text{ lb}$
- (2) $V_B = V_A + \text{Area in load diagram}$
 $V_B = 300 + 0 = 300 \text{ lb}$
- (3) $V_C = V_B + \text{Area in load diagram}$
 $V_C = 300 + 0 = 300 \text{ lb}$
 $V_{C2} = V_C + R_2 = 300 + 450 = 750 \text{ lb}$
- (5) $V_D = V_{C2} + \text{Area in load diagram}$
 $V_D = 750 + 0 = 750$
 $V_{D2} = V_D - 750 = 750 - 750 = 0$

To draw the Moment Diagram

- (1) $M_A = 0$
- (2) $M_B = V_A + \text{Area in shear diagram}$
 $M_B = 0 + 300(2) = 600 \text{ lb-ft}$
 $M_{B2} = V_B - 3000$
 $M_{B2} = 600 - 3000 = -2400 \text{ lb-ft}$
- (3) $M_C = M_{B2} + \text{Area in shear diagram}$
 $M_C = -2400 + 300(3) = -1500 \text{ lb-ft}$
- (4) $M_D = M_C + \text{Area in shear diagram}$
 $M_D = -1500 + 750(2) = 0$

Problem 434

Beam loaded as shown in Fig. P-434.

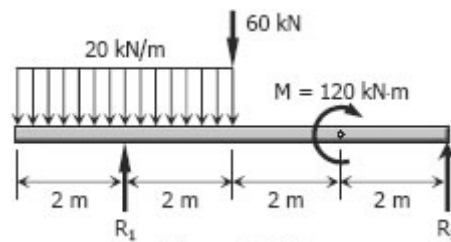
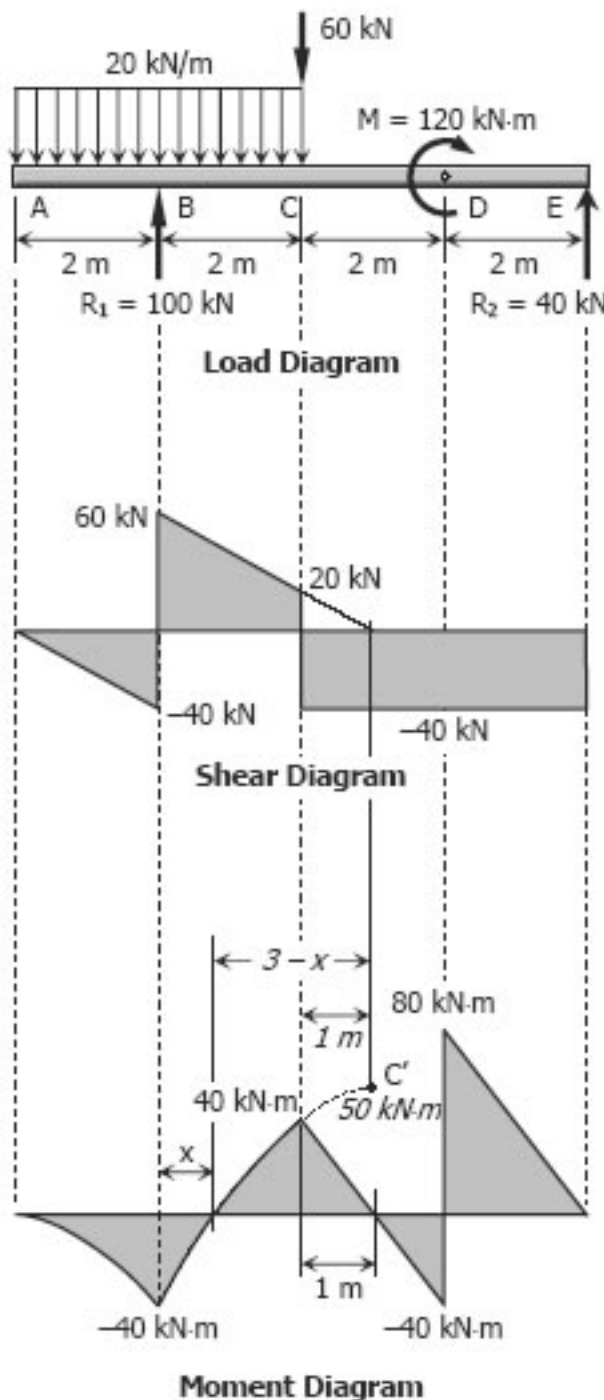

Figure P-434

Solution 434



$$\sum M_E = 0$$

$$6R_1 + 120 = 20(4)(6) + 60(4)$$

$$R_1 = 100 \text{ kN}$$

$$\sum M_B = 0$$

$$6R_2 = 20(4)(0) + 60(2) + 120$$

$$R_2 = 40 \text{ kN}$$

To draw the Shear Diagram

- (1) $V_A = 0$
- (2) $V_B = V_A + \text{Area in load diagram}$
 $V_B = 0 - 20(2) = -40 \text{ kN}$
 $V_{B2} = V_B + R_1 = -40 + 100 = 60 \text{ kN}$
- (3) $V_C = V_{B2} + \text{Area in load diagram}$
 $V_C = 60 - 20(2) = 20 \text{ kN}$
 $V_{C2} = V_C - 60 = 20 - 60 = -40 \text{ kN}$
- (4) $V_D = V_{C2} + \text{Area in load diagram}$
 $V_D = -40 + 0 = -40 \text{ kN}$
- (5) $V_E = V_D + \text{Area in load diagram}$
 $V_E = -40 + 0 = -40 \text{ kN}$
 $V_{E2} = V_E + R_2 = -40 + 40 = 0$

To draw the Moment Diagram

- (1) $M_A = 0$
- (2) $M_B = M_A + \text{Area in shear diagram}$
 $M_B = 0 - \frac{1}{2}(40)(2) = -40 \text{ kN-m}$
- (3) $M_C = M_B + \text{Area in shear diagram}$
 $M_C = -40 + \frac{1}{2}(60 + 20)(2) = 40 \text{ kN-m}$
- (4) $M_D = M_C + \text{Area in shear diagram}$
 $M_D = 40 - 40(2) = -40 \text{ kN-m}$
 $M_{D2} = M_D + M = -40 + 120 = 80 \text{ kN-m}$
- (5) $M_E = M_{D2} + \text{Area in shear diagram}$
 $M_E = 80 - 40(2) = 0$
- (6) Moment curve BC is a downward parabola with vertex at C'. C' is the location of zero shear for segment BC.
- (7) Location of zero moment at segment BC:
 By squared property of parabola:
 $(3 - x)^2 / 50 = 3^2 / (50 + 40)$
 $3 - x = 2.236$
 $x = 0.764 \text{ m from B}$

Problem 435

Beam loaded and supported as shown in Fig. P-435.

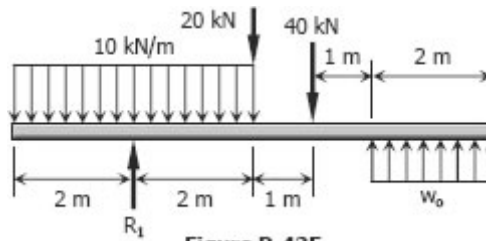
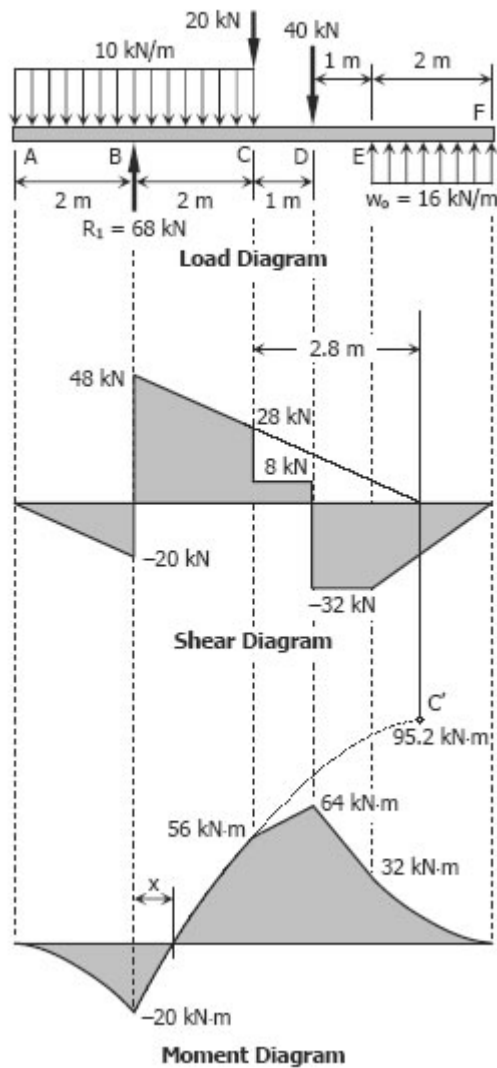

Figure P-435

Solution 435



$$\sum M_B = 0$$

$$2w_o(5) = 10(4)(0) + 20(2) + 40(3)$$

$$w_o = 16 \text{ kN/m}$$

$$\sum M_{\text{midpoint of EF}} = 0$$

$$5R_1 = 10(4)(5) + 20(3) + 40(2)$$

$$R_1 = 68 \text{ kN}$$

To draw the Shear Diagram

- (1) $M_A = 0$
- (2) $M_B = M_A + \text{Area in load diagram}$
 $M_B = 0 - 10(2) = -20 \text{ kN}$
 $M_{B2} + M_B + R_1 = -20 + 68 = 48 \text{ kN}$
- (3) $M_C = M_{B2} + \text{Area in load diagram}$
 $M_C = 48 - 10(2) = 28 \text{ kN}$
 $M_{C2} = M_C - 20 = 28 - 20 = 8 \text{ kN}$
- (4) $M_D = M_{C2} + \text{Area in load diagram}$
 $M_D = 8 + 0 = 8 \text{ kN}$
 $M_{D2} = M_D - 40 = 8 - 40 = -32 \text{ kN}$
- (5) $M_E = M_{D2} + \text{Area in load diagram}$
 $M_E = -32 + 0 = -32 \text{ kN}$
- (6) $M_F = M_E + \text{Area in load diagram}$
 $M_F = -32 + w_o(2)$
 $M_F = -32 + 16(2) = 0$

To draw the Moment Diagram

- (1) $M_A = 0$
- (2) $M_B = M_A + \text{Area in shear diagram}$
 $M_B = 0 - \frac{1}{2}(20)(2) = -20 \text{ kN-m}$
- (3) $M_C = M_B + \text{Area in shear diagram}$
 $M_C = -20 + \frac{1}{2}(48 + 28)(2)$
 $M_C = 56 \text{ kN-m}$
- (4) $M_D = M_C + \text{Area in shear diagram}$
 $M_D = 56 + 8(1) = 64 \text{ kN-m}$
- (5) $M_E = M_D + \text{Area in shear diagram}$
 $M_E = 64 - 32(1) = 32 \text{ kN-m}$
- (6) $M_F = M_E + \text{Area in shear diagram}$
 $M_F = 32 - \frac{1}{2}(32)(2) = 0$
- (7) The location and magnitude of moment at C' are determined from shear diagram. By squared property of parabola, $x = 0.44 \text{ m}$ from B.

Problem 437

Cantilever beam loaded as shown in Fig. P-437

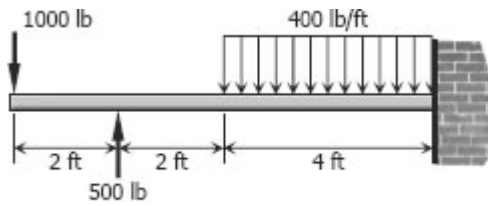
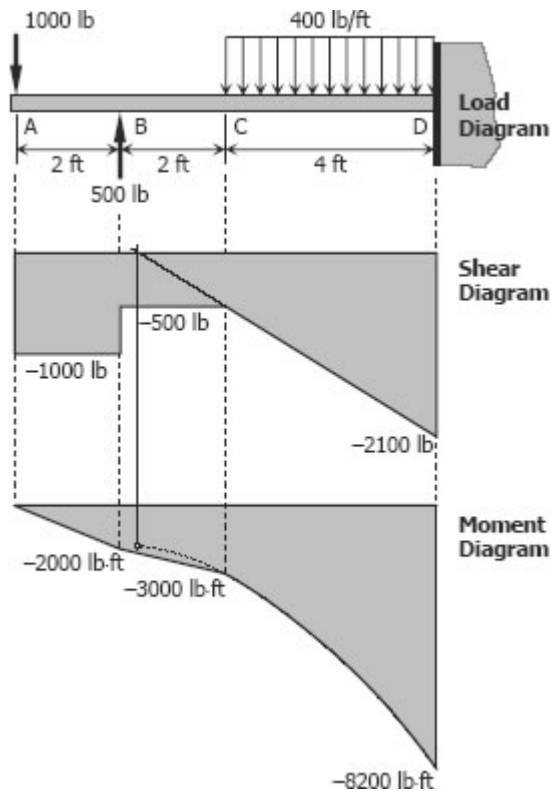

Figure P-437

Solution 437



To draw the Shear Diagram

- (1) $V_A = -1000 \text{ lb}$
 $V_B = V_A + \text{Area in load diagram}$
 $V_B = -1000 + 0 = -1000 \text{ lb}$
 $V_{B2} = V_B + 500 = -1000 + 500$
 $V_{B2} = -500 \text{ lb}$
- (2) $V_C = V_{B2} + \text{Area in load diagram}$
 $V_C = -500 + 0 = -500 \text{ lb}$
- (3) $V_D = V_C + \text{Area in load diagram}$
 $V_D = -500 - 400(4) = -2100 \text{ lb}$

To draw the Moment Diagram

- (1) $M_A = 0$
- (2) $M_B = M_A + \text{Area in shear diagram}$
 $M_B = 0 - 1000(2) = -2000 \text{ lb-ft}$
- (3) $M_C = M_B + \text{Area in shear diagram}$
 $M_C = -2000 - 500(2) = -3000 \text{ lb-ft}$
- (4) $M_D = M_C + \text{Area in shear diagram}$
 $M_D = -3000 - \frac{1}{2}(500 + 2100)(4)$
 $M_D = -8200 \text{ lb-ft}$

Problem 438

The beam loaded as shown in Fig. P-438 consists of two segments joined by a frictionless hinge at which the bending moment is zero.

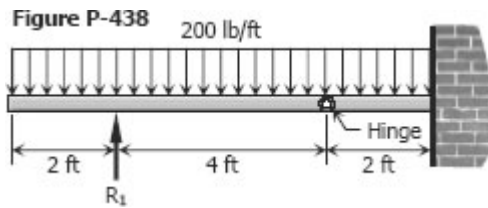

Solution 438

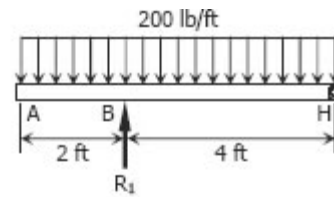
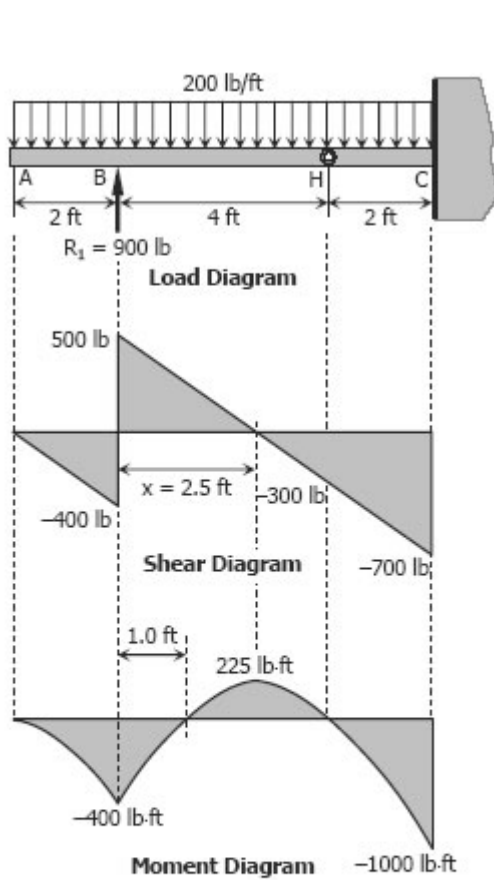

$$\begin{aligned}\sum M_H &= 0 \\ 4R_1 &= 200(6)(3) \\ R_1 &= 900 \text{ lb}\end{aligned}$$

To draw the Shear Diagram

- (1) $V_A = 0$
- (2) $V_B = V_A + \text{Area in load diagram}$
 $V_B = 0 - 200(2) = -400 \text{ lb}$
 $V_{B2} = V_B + R_1 = -400 + 900 = 500 \text{ lb}$
- (3) $V_H = V_{B2} + \text{Area in load diagram}$
 $V_H = 500 - 200(4) = -300 \text{ lb}$
- (4) $V_C = V_H + \text{Area in load diagram}$
 $V_C = -300 - 200(2) = -700 \text{ lb}$
- (5) Location of zero shear:
 $x / 500 = (4 - x) / 300$
 $300x = 2000 - 500x$
 $x = 2.5 \text{ ft}$

To draw the Moment Diagram

- (1) $M_A = 0$
- (2) $M_B = M_A + \text{Area in shear diagram}$
 $M_B = 0 - \frac{1}{2}(400)(2) = -400 \text{ lb-ft}$
- (3) $M_x = M_B + \text{Area in load diagram}$
 $M_x = -400 + \frac{1}{2}(500)(2.5)$
 $M_x = 225 \text{ lb-ft}$
- (4) $M_H = M_x + \text{Area in load diagram}$
 $M_H = 225 - \frac{1}{2}(300)(4 - 2.5) = 0 \text{ ok!}$
- (5) $M_C = M_H + \text{Area in load diagram}$
 $M_C = 0 - \frac{1}{2}(300 + 700)(2)$
 $M_C = -1000 \text{ lb-ft}$
- (6) The location of zero moment in segment BH can easily be found by symmetry.

Problem 439

A beam supported on three reactions as shown in Fig. P-439 consists of two segments joined by frictionless hinge at which the bending moment is zero.

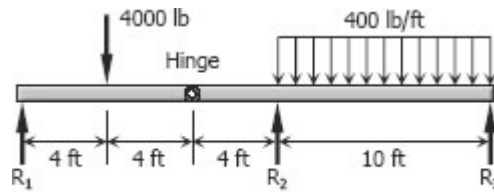
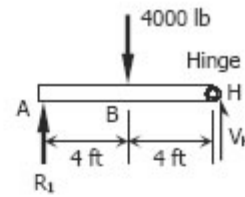
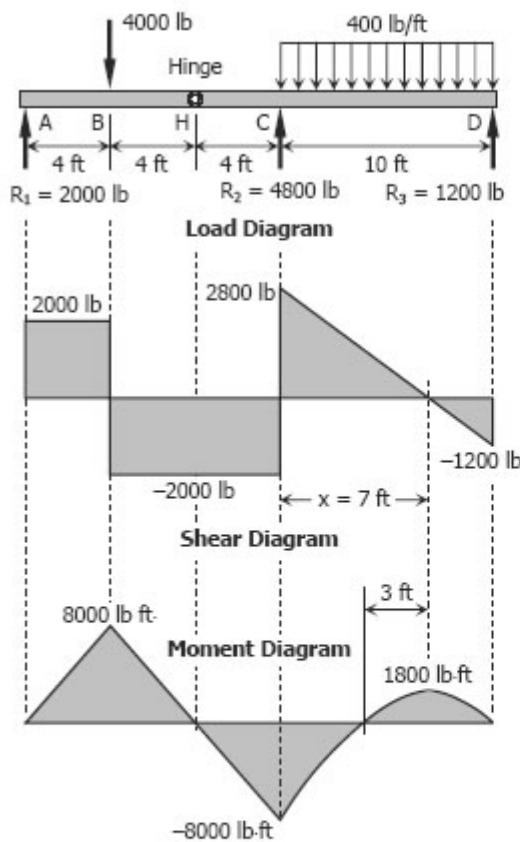
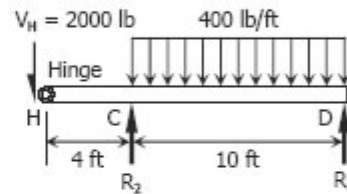

Figure P-439

Solution 439



$$\begin{aligned} \sum M_H = 0 & \quad \sum M_A = 0 \\ 8R_1 = 4000(4) & \quad 8V_H = 4000(4) \\ R_1 = 2000 \text{ lb} & \quad V_H = 2000 \text{ lb} \end{aligned}$$



$$\begin{aligned} \sum M_D = 0 \\ 10R_2 = 2000(14) + 400(10)(5) \\ R_2 = 4800 \text{ lb} \end{aligned}$$

$$\begin{aligned} \sum M_H = 0 \\ 14R_3 + 4(4800) = 400(10)(9) \\ R_3 = 1200 \text{ lb} \end{aligned}$$

To draw the Shear Diagram

- (1) $V_A = 0$
- (2) $V_B = 2000 \text{ lb}$
 $V_{B2} = 2000 - 4000 = -2000 \text{ lb}$
- (3) $V_H = -2000 \text{ lb}$
- (3) $V_C = -2000 \text{ lb}$
 $V_C = -2000 + 4800 = 2800 \text{ lb}$
- (4) $V_D = 2800 - 400(10) = -1200 \text{ lb}$

- (5) Location of zero shear:
 $x / 2800 = (10 - x) / 1200$
 $1200x = 28000 - 2800x$
 $x = 7 \text{ ft}$

To draw the Moment Diagram

- (1) $M_A = 0$
- (2) $M_B = 2000(4) = 8000 \text{ lb-ft}$

- (3) $M_H = 8000 - 4000(2) = 0$
- (4) $M_C = -400(2)$
 $M_C = -800 \text{ lb-ft}$
- (5) $M_x = -800 + \frac{1}{2}(2800)(7)$
 $M_x = 1800 \text{ lb-ft}$
- (6) $M_D = 1800 - \frac{1}{2}(1200)(3)$
 $M_D = 0$
- (7) Zero M is 4 ft from R_2

Problem 440

A frame ABCD, with rigid corners at B and C, supports the concentrated load as shown in Fig. P-440. (Draw shear and moment diagrams for each of the three parts of the frame.)

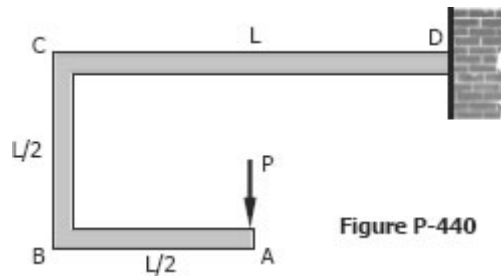
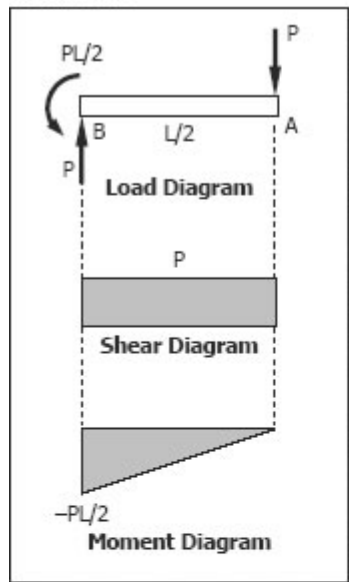

Figure P-440

Solution 440

Member AB



Member BC

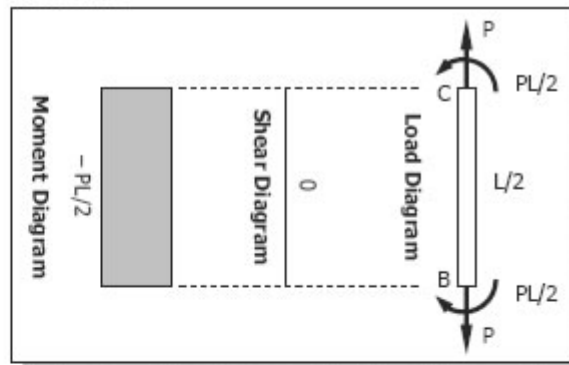

Member CD

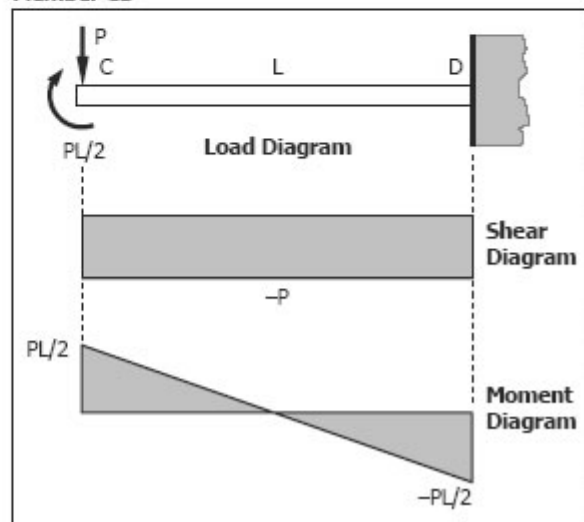

Problem 441

A beam ABCD is supported by a roller at A and a hinge at D. It is subjected to the loads shown in Fig. P-441, which act at the ends of the vertical members BE and CF. These vertical members are rigidly attached to the beam at B and C. (Draw shear and moment diagrams for the beam ABCD only.)

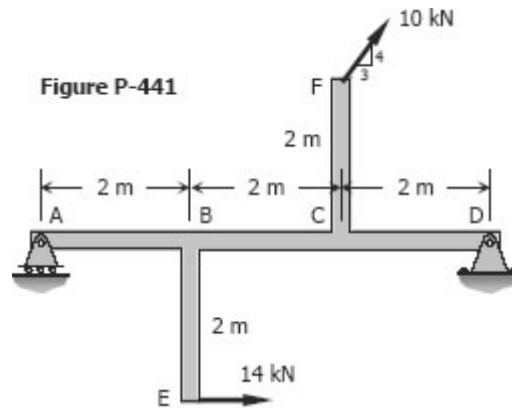

Solution 441

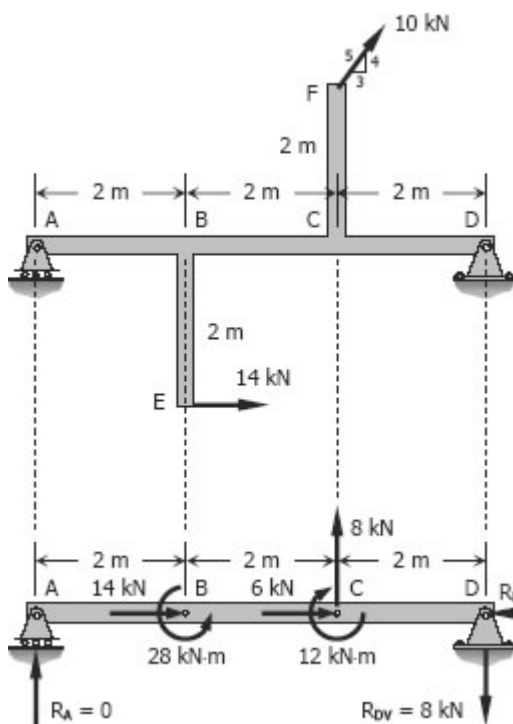

$$F_{BH} = 14 \text{ kN to the right}$$

$$M_B = 14(2)$$

$$= 28 \text{ kN}\cdot\text{m counterclockwise}$$

$$F_{CH} = \frac{3}{5}(10)$$

$$= 6 \text{ kN to the right}$$

$$F_{CV} = \frac{4}{5}(10)$$

$$= 8 \text{ kN upward}$$

$$M_C = F_{CH}(2) = 6(2)$$

$$= 12 \text{ kN}\cdot\text{m clockwise}$$

$$\sum M_D = 0$$

$$6R_A + 12 + 8(2) = 28$$

$$R_A = 0$$

$$\sum M_A = 0$$

$$6R_{DV} + 12 = 28 + 8(4)$$

$$R_{DV} = 8 \text{ kN}$$

$$\sum F_H = 0$$

$$R_{DH} = 14 + 6$$

$$= 20 \text{ kN}$$

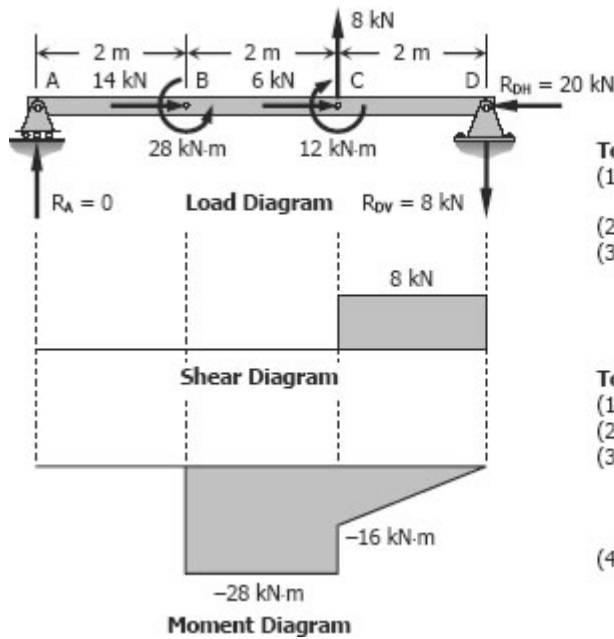

To draw the Shear Diagram

- (1) Shear in segments AB and BC is zero.
- (2) $V_C = 8$
- (3) $V_D = V_C + \text{Area in load diagram}$
 $V_D = 8 + 0 = 8 \text{ kN}$
 $V_{D2} = V_D - R_{DV}$
 $V_{D2} = 8 - 8 = 0$

To draw the Moment Diagram

- (1) Moment in segment AB is zero
- (2) $M_B = -28 \text{ kN-m}$
- (3) $M_C = M_B + \text{Area in shear diagram}$
 $M_C = -28 + 0 = -28 \text{ kN-m}$
 $M_{C2} = M_C + 12 = -28 + 12$
 $M_{C2} = -16 \text{ kN-m}$
- (4) $M_D = M_{C2} + \text{Area in shear diagram}$
 $M_D = -16 + 8(2)$
 $M_D = 0$

Problem 442

Beam carrying the uniformly varying load shown in Fig. P-442.

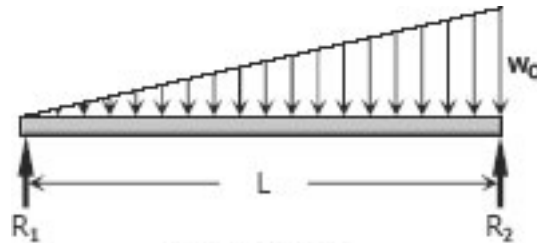
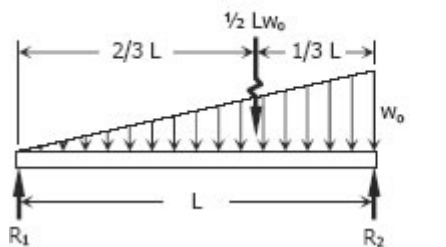

Figure P-442

Solution 442



$$\sum M_{R2} = 0$$

$$LR_1 = \frac{1}{3} L \left(\frac{1}{2} L w_0 \right)$$

$$R_1 = \frac{1}{6} L w_0$$

$$\sum M_{R1} = 0$$

$$LR_2 = \frac{2}{3} L \left(\frac{1}{2} L w_0 \right)$$

$$R_2 = \frac{1}{3} L w_0$$

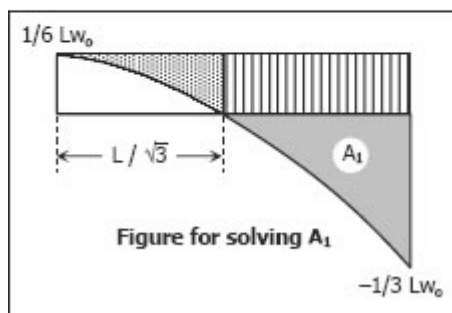
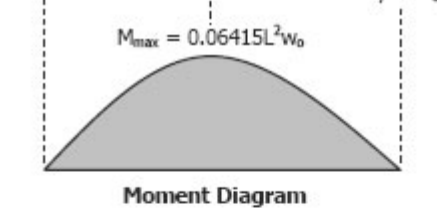
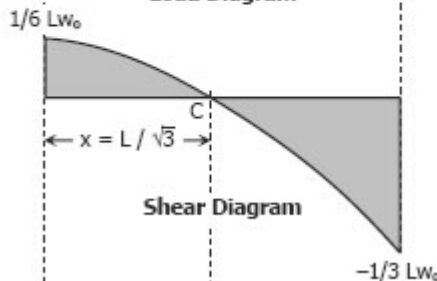
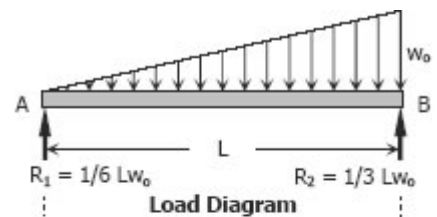

To draw the Shear Diagram

- (1) $V_A = R_1 = 1/6 L w_0$
- (2) $V_B = V_A + \text{Area in load diagram}$
 $V_B = 1/6 L w_0 - 1/2 L w_0$
 $V_B = -1/3 L w_0$
- (3) Location of zero shear C:
 By squared property of parabola:
 $x^2 / (1/6 L w_0) = L^2 / (1/6 L w_0 + 1/3 L w_0)$
 $6x^2 = 2L^2$
 $x = L / \sqrt{3}$
- (4) The shear in AB is a parabola with vertex at A, the starting point of uniformly varying load. The load in AB is 0 at A to downward w_0 or $-w_0$ at B, thus the slope of shear diagram is decreasing. For decreasing slope, the parabola is open downward.

To draw the Moment Diagram

- (1) $M_A = 0$
- (2) $M_C = M_A + \text{Area in shear diagram}$
 $M_C = 0 + 2/3 (L/\sqrt{3})(1/6 L w_0)$
 $M_C = 0.06415 L^2 w_0 = M_{\max}$
- (3) $M_B = M_C + \text{Area in shear diagram}$
 $M_B = M_C - A_1 \rightarrow \text{see figure for solving } A_1$
 For A_1 :
 $A_1 = 1/3 L(1/6 L w_0 + 1/3 L w_0)$
 $\quad - 1/3 (L/\sqrt{3})(1/6 L w_0)$
 $\quad - 1/6 L w_0 (L - L/\sqrt{3})$
 $A_1 = 0.16667 L^2 w_0 - 0.03208 L^2 w_0$
 $\quad - 0.07044 L^2 w_0$
 $A_1 = 0.06415 L^2 w_0$
 $M_B = 0.06415 L^2 w_0 - 0.06415 L^2 w_0 = 0$
- (4) The shear diagram is second degree curve, thus the moment diagram is a third degree curve. The maximum moment (highest point) occurred at C, the location of zero shear. The value of shears in AC is positive then the moment in AC is increasing; at CB the shear is negative, then the moment in CB is decreasing.

Problem 443

Beam carrying the triangular loads shown in Fig. P-443.

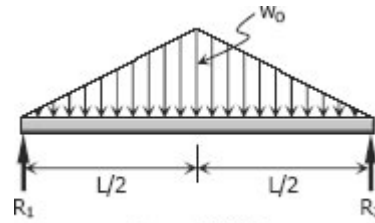

Figure P-443

Solution 443

By symmetry:

$$R_1 = R_2 = \frac{1}{2} \left(\frac{1}{2} L w_0 \right)$$

$$R_1 = R_2 = \frac{1}{4} L w_0$$

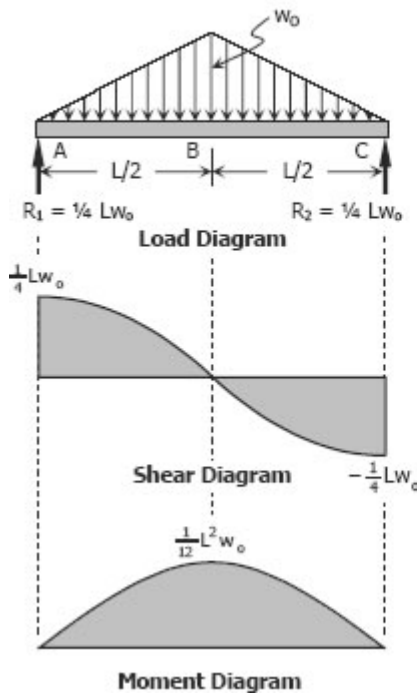

To draw the Shear Diagram

- (1) $V_A = R_1 = \frac{1}{4} L w_0$
- (2) $V_B = V_A + \text{Area in load diagram}$
 $V_B = \frac{1}{4} L w_0 - \frac{1}{2} (L/2)(w_0) = 0$
- (3) $V_C = V_B + \text{Area in load diagram}$
 $V_C = 0 - \frac{1}{2} (L/2)(w_0) = -\frac{1}{4} L w_0$
- (4) Load in AB is linear, thus, V_{AB} is second degree or parabolic curve. The load is from 0 at A to w_0 (w_0 is downward or $-w_0$) at B, thus the slope of V_{AB} is decreasing.
- (5) V_{BC} is also parabolic since the load in BC is linear. The magnitude of load in BC is from $-w_0$ to 0 or increasing, thus the slope of V_{BC} is increasing.

To draw the Moment Diagram

- (1) $M_A = 0$
- (2) $M_B = M_A + \text{Area in shear diagram}$
 $M_B = 0 + \frac{2}{3} (L/2) \left(\frac{1}{4} L w_0 \right) = \frac{1}{12} L w_0$
- (3) $M_C = M_B + \text{Area in shear diagram}$
 $M_C = \frac{1}{12} L w_0 - \frac{2}{3} (L/2) \left(\frac{1}{4} L w_0 \right) = 0$
- (4) M_{AC} is third degree because the shear diagram in AC is second degree.
- (5) The shear from A to C is decreasing, thus the slope of moment diagram from A to C is decreasing.

Problem 444

Beam loaded as shown in Fig. P-444.

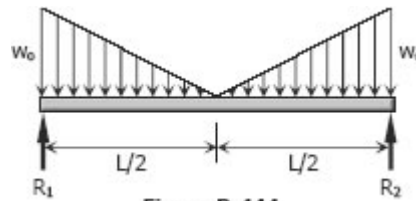

Figure P-444

Solution 444

Total load

$$= 2\left[\frac{1}{2}(L/2)(w_0)\right]$$

$$= \frac{1}{2}Lw_0$$

By symmetry

$$R_1 = R_2 = \frac{1}{2} \times \text{total load}$$

$$R_1 = R_2 = \frac{1}{4}Lw_0$$

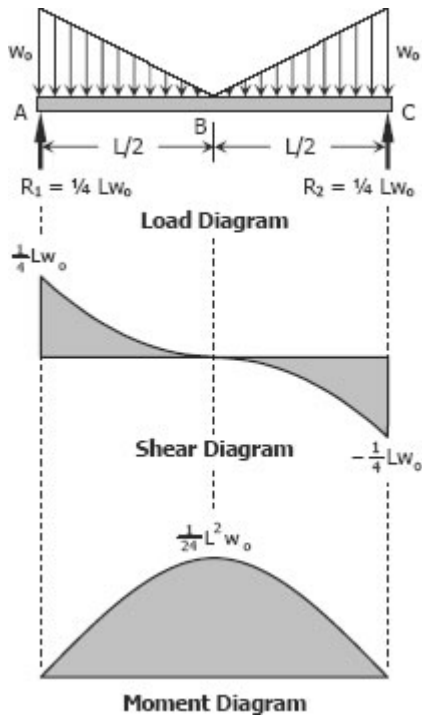

To draw the Shear Diagram

- (1) $V_A = R_1 = \frac{1}{4}Lw_0$
- (2) $V_B = V_A + \text{Area in load diagram}$
 $V_B = \frac{1}{4}Lw_0 - \frac{1}{2}(L/2)(w_0) = 0$
- (3) $V_C = V_B + \text{Area in load diagram}$
 $V_C = 0 - \frac{1}{2}(L/2)(w_0) = -\frac{1}{4}Lw_0$
- (4) The shear diagram in AB is second degree curve. The shear in AB is from $-w_0$ (downward w_0) to zero or increasing, thus, the slope of shear at AB is increasing (upward parabola).
- (5) The shear diagram in BC is second degree curve. The shear in BC is from zero to $-w_0$ (downward w_0) or decreasing, thus, the slope of shear at BC is decreasing (downward parabola)

To draw the Moment Diagram

- (1) $M_A = 0$
- (2) $M_B = M_A + \text{Area in shear diagram}$
 $M_B = 0 + \frac{1}{3}(L/2)(\frac{1}{4}Lw_0) = \frac{1}{24}L^2w_0$
- (3) $M_C = M_B + \text{Area in shear diagram}$
 $M_C = \frac{1}{24}L^2w_0 - \frac{1}{3}(L/2)(\frac{1}{4}Lw_0) = 0$
- (4) The shear diagram from A to C is decreasing, thus, the moment diagram is a concave downward third degree curve.

Problem 445

Beam carrying the loads shown in Fig. P-445.

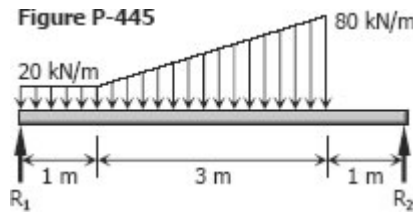

Solution 445

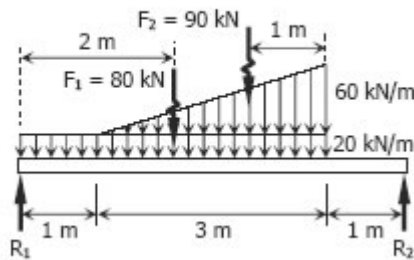

$$\sum M_{R2} = 0$$

$$5R_1 = 80(3) + 90(2)$$

$$R_1 = 84 \text{ kN}$$

$$\sum M_{R1} = 0$$

$$5R_2 = 80(2) + 90(3)$$

$$R_2 = 86 \text{ kN}$$

Checking

$$R_1 + R_2 = F_1 + F_2 \text{ ok!}$$

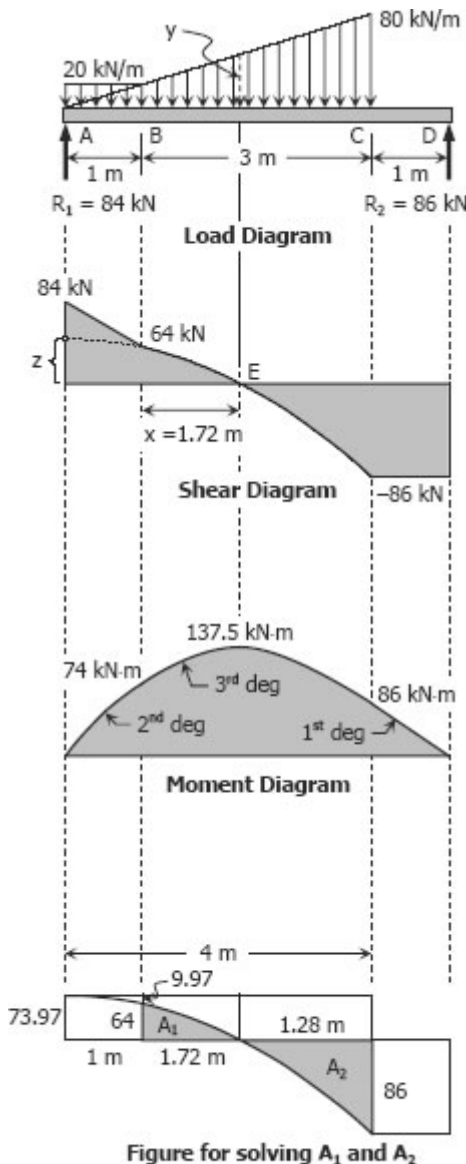

Figure for solving A_1 and A_2

To draw the Shear Diagram

- (1) $V_A = R_1 = 84 \text{ kN}$
- (2) $V_B = V_A + \text{Area in load diagram}$
 $V_B = 84 - 20(1) = 64 \text{ kN}$
- (3) $V_C = V_B + \text{Area in load diagram}$
 $V_C = 64 - \frac{1}{2}(20 + 80)(3) = -86 \text{ kN}$
- (4) $V_D = V_C + \text{Area in load diagram}$
 $V_D = -86 + 0 = -86 \text{ kN}$
 $V_{D2} = V_D + R_2 = -86 + 86 = 0$
- (5) Location of zero shear:
 From the load diagram:
 $y / (x + 1) = 80 / 4$
 $y = 20(x + 1)$
 $V_E = V_B + \text{Area in load diagram}$
 $0 = 64 - \frac{1}{2}(20 + y)x$
 $(20 + y)x = 128$
 $[20 + 20(x + 1)]x = 128$
 $20x^2 + 40x - 128 = 0$
 $5x^2 + 10x - 32 = 0$
 $x = 1.72 \text{ and } -3.72$
 use $x = 1.72 \text{ m}$ from B
- (5) By squared property of parabola:
 $z / (1 + x)^2 = (z + 86) / 4^2$
 $16z = 7.3984z + 636.2624$
 $8.6016z = 254.4224$
 $z = 73.97 \text{ kN}$

To draw the Moment Diagram

- (1) $M_A = 0$
- (2) $M_B = M_A + \text{Area in shear diagram}$
 $M_B = 0 + \frac{1}{2}(84 + 64)(1) = 74 \text{ kN-m}$
- (3) $M_E = M_B + \text{Area in shear diagram}$
 $M_E = 74 + A_1 \rightarrow \text{see figure for } A_1 \text{ and } A_2$
 For A_1 :
 $A_1 = \frac{2}{3}(1 + 1.72)(73.97) - 64(1)$
 $\quad - \frac{2}{3}(1)(9.97)$
 $A_1 = 63.5$
 $M_E = 74 + 63.5 = 137.5 \text{ kN-m}$
- (4) $M_C = M_E + \text{Area in shear diagram}$
 $M_C = M_E - A_2$
 For A_2 :
 $A_2 = \frac{1}{3}(4)(73.97 + 86)$
 $\quad - \frac{1}{3}(1 + 1.72)(73.97)$
 $\quad - 1.28(73.97)$
 $A_2 = 51.5$
 $M_C = 137.5 - 51.5 = 86 \text{ kN-m}$
- (5) $M_D = M_C + \text{Area in shear diagram}$
 $M_D = 86 - 86(1) = 0$

Problem 446

Beam loaded and supported as shown in Fig. P-446.

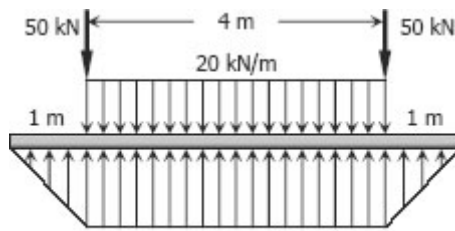
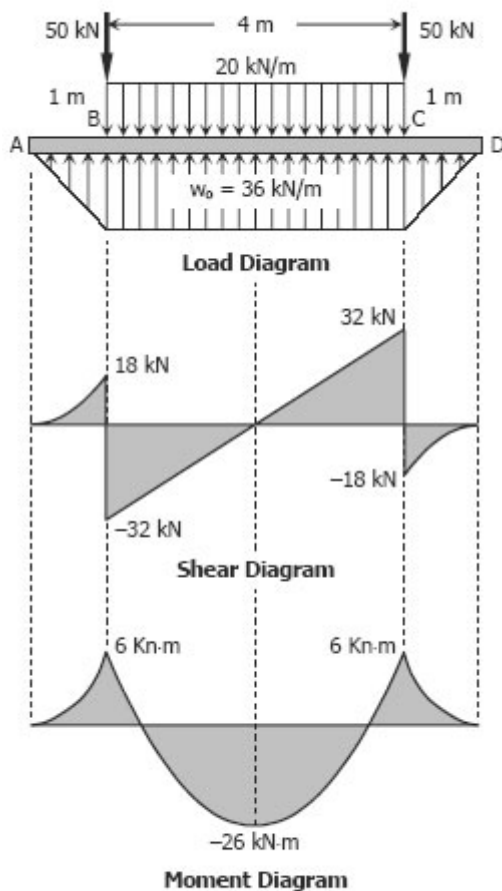

Figure P-446

Solution 446



$$\sum F_V = 0$$

$$4w_o + 2\left[\frac{1}{2}w_o(1)\right] = 20(4) + 2(50)$$

$$5w_o = 180$$

$$w_o = 36 \text{ kN/m}$$

To draw the Shear Diagram

- (1) $V_A = 0$
- (2) $V_B = V_A + \text{Area in load diagram}$
 $V_B = 0 + \frac{1}{2}(36)(1) = 18 \text{ kN}$
 $V_{B2} = V_B - 50 = 18 - 50$
 $V_{B2} = -32 \text{ kN}$
- (3) The net uniformly distributed load in segment BC is $36 - 20 = 16 \text{ kN/m}$ upward.
 $V_C = V_{B2} + \text{Area in load diagram}$
 $V_C = -32 + 16(4) = 32 \text{ kN}$
 $V_{C2} = V_C - 50 = 32 - 50$
 $V_{C2} = -18 \text{ kN}$
- (4) $V_D = V_{C2} + \text{Area in load diagram}$
 $V_D = -18 + \frac{1}{2}(36)(1) = 0$
- (5) The shape of shear at AB and CD are parabolic spandrel with vertex at A and D, respectively.
- (6) The location of zero shear is obviously at the midspan or 2 m from B.

To draw the Moment Diagram

- (1) $M_A = 0$
- (2) $M_B = M_A + \text{Area in shear diagram}$
 $M_B = 0 + \frac{1}{3}(1)(18)$
 $M_B = 6 \text{ kN-m}$
- (3) $M_{\text{midspan}} = M_B + \text{Area in shear diagram}$
 $M_{\text{midspan}} = 6 - \frac{1}{2}(32)(2)$
 $M_{\text{midspan}} = -26 \text{ kN-m}$
- (4) $M_C = M_{\text{midspan}} + \text{Area in shear diagram}$
 $M_C = -26 + \frac{1}{2}(32)(2)$
 $M_C = 6 \text{ kN-m}$
- (5) $M_D = M_C + \text{Area in shear diagram}$
 $M_D = 6 - \frac{1}{3}(1)(18) = 0$
- (6) The moment diagram at AB and CD are 3rd degree curve while at BC is 2nd degree curve.

Finding the Load & Moment Diagrams with Given Shear Diagram

INSTRUCTION

In the following problems, draw moment and load diagrams corresponding to the given shear diagrams. Specify values at all change of load positions and at all points of zero shear.

Problem 447

Shear diagram as shown in Fig. P-447.

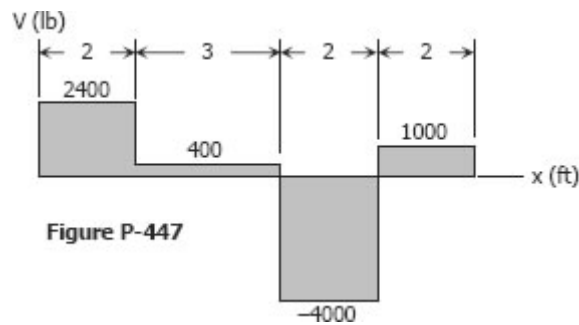
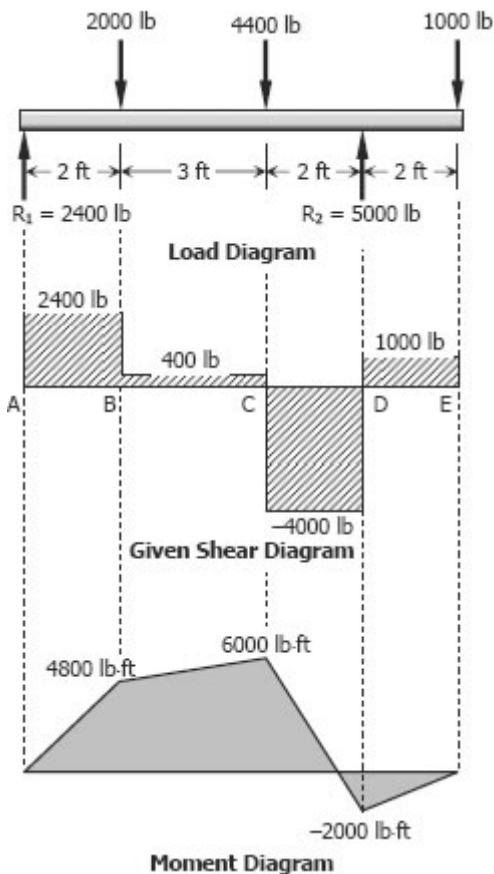

Figure P-447

Solution 447



To draw the Load Diagram

- (1) A 2400 lb upward force is acting at point A. No load in segment AB.
- (2) A point force of $2400 - 400 = 2000$ lb is acting downward at point B. No load in segment BC.
- (3) Another downward force of magnitude $400 + 4000 = 4400$ lb at point C. No load in segment CD.
- (4) Upward point force of $4000 + 1000 = 5000$ lb is acting at D. No load in segment DE.
- (5) A downward force of 1000 lb is concentrated at point E.

To draw the Moment Diagram

- (1) $M_A = 0$
- (2) $M_B = M_A + \text{Area in shear diagram}$
 $M_B = 0 + 2400(2) = 4800$ lb-ft
 M_{AB} is linear and upward
- (3) $M_C = M_B + \text{Area in shear diagram}$
 $M_C = 4800 + 400(3) = 6000$ lb-ft
 M_{BC} is linear and upward
- (4) $M_D = M_C + \text{Area in shear diagram}$
 $M_D = 6000 - 4000(2) = -2000$ lb-ft
 M_{CD} is linear and downward
- (5) $M_E = M_D + \text{Area in shear diagram}$
 $M_E = -2000 + 1000(2) = 0$
 M_{DE} is linear and upward

Problem 448

Shear diagram as shown in Fig. P-448.

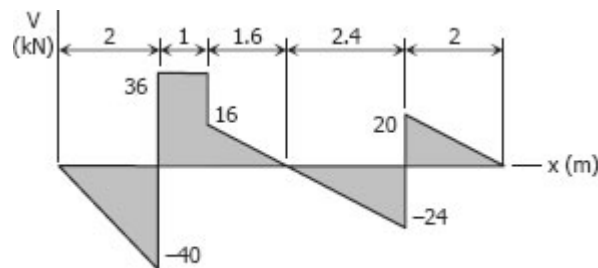
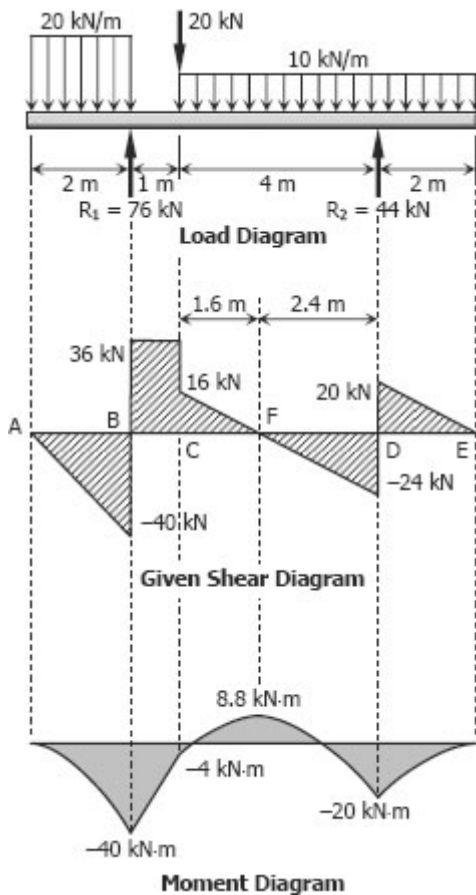

Figure P-448

Solution 448



To draw the Load Diagram

- (1) A uniformly distributed load in AB is acting downward at a magnitude of $40/2 = 20$ kN/m.
- (2) Upward concentrated force of $40 + 36 = 76$ kN acts at B. No load in segment BC.
- (3) A downward point force acts at C at a magnitude of $36 - 16 = 20$ kN.
- (4) Downward uniformly distributed load in CD has a magnitude of $(16 + 24)/4 = 10$ kN/m & causes zero shear at point F, 1.6 m from C.
- (5) Another upward concentrated force acts at D at a magnitude of $20 + 24 = 44$ kN.
- (6) The load in segment DE is uniform and downward at $20/2 = 10$ kN/m.

To draw the Moment Diagram

- (1) $M_A = 0$
- (2) $M_B = M_A + \text{Area in shear diagram}$
 $M_B = 0 - \frac{1}{2} (40)(2) = -40$ kN-m
 M_{AB} is downward parabola with vertex at A.
- (3) $M_C = M_B + \text{Area in shear diagram}$
 $M_C = -40 + 36(1) = -4$ kN-m
 M_{BC} is linear and upward
- (4) $M_F = M_C + \text{Area in shear diagram}$
 $M_F = -4 + \frac{1}{2} (16)(1.6) = 8.8$ kN-m
- (5) $M_D = M_F + \text{Area in shear diagram}$
 $M_D = 8.8 - \frac{1}{2} (24)(2.4) = -20$ kN-m
 M_{CD} is downward parabola with vertex at F.
- (6) $M_E = M_D + \text{Area in shear diagram}$
 $M_E = -20 + \frac{1}{2} (20)(2) = 0$
 M_{DE} is downward parabola with vertex at E.

Problem 449

Shear diagram as shown in Fig. P-449.

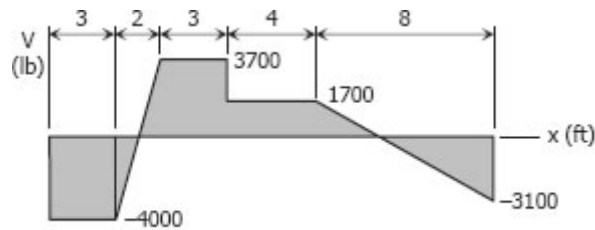
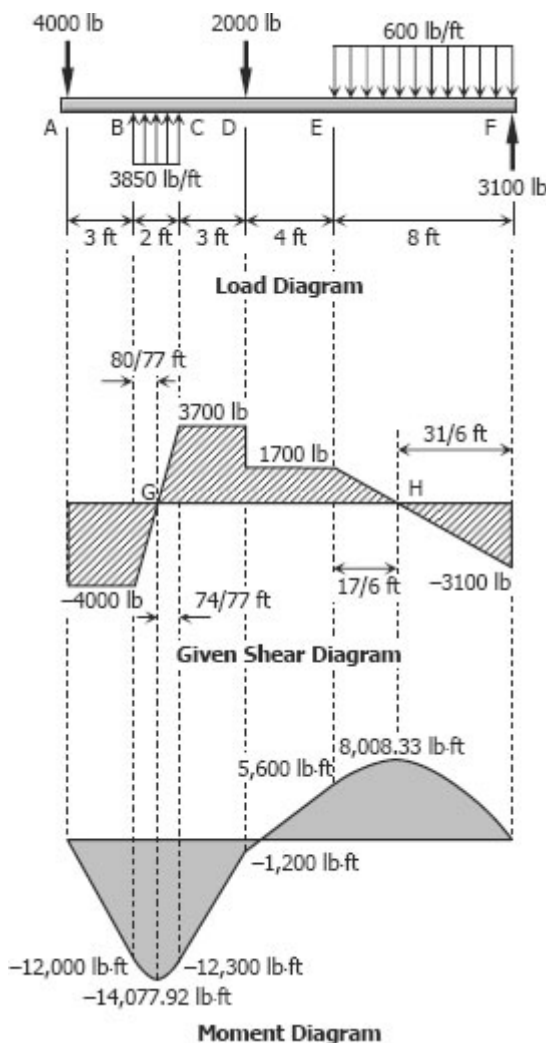

Figure P-449

Solution 449



To draw the Load Diagram

- (1) Downward 4000 lb force is concentrated at A and no load in segment AB.
- (2) The shear in BC is uniformly increasing, thus a uniform upward force is acting at a magnitude of $(3700 + 4000)/2 = 3850$ lb/ft. No load in segment CD.
- (3) Another point force acting downward with $3700 - 1700 = 1200$ lb at D and no load in segment DE.
- (4) The shear in EF is uniformly decreasing, thus a uniform downward force is acting with magnitude of $(1700 + 3100)/8 = 600$ lb/ft.
- (5) Upward force of 3100 lb is concentrated at end of span F.

To draw the Moment Diagram

- (1) The locations of zero shear (points G and H) can be easily determined by ratio and proportion of triangle.
- (2) $M_A = 0$
- (3) $M_B = M_A + \text{Area in shear diagram}$
 $M_B = 0 - 4000(3) = -12,000$ lb-ft
- (4) $M_G = M_B + \text{Area in shear diagram}$
 $M_G = -12,000 - \frac{1}{2}(80/77)(4000)$
 $M_G = -14,077.92$ lb-ft
- (5) $M_C = M_G + \text{Area in shear diagram}$
 $M_C = -14,077.92 + \frac{1}{2}(74/77)(3700)$
 $M_C = -12,300$ lb-ft
- (6) $M_D = M_C + \text{Area in shear diagram}$
 $M_D = -12,300 + 3700(3) = -1200$ lb-ft
- (7) $M_E = M_D + \text{Area in shear diagram}$
 $M_E = -1200 + 1700(4) = 5600$ lb-ft
- (8) $M_H = M_E + \text{Area in shear diagram}$
 $M_H = 5600 + \frac{1}{2}(17/6)(1700)$
 $M_H = 8,008.33$ lb-ft
- (9) $M_F = M_H + \text{Area in shear diagram}$
 $M_F = 8,008.33 - \frac{1}{2}(31/6)(3100) = 0$

Problem 450

Shear diagram as shown in Fig. P-450.

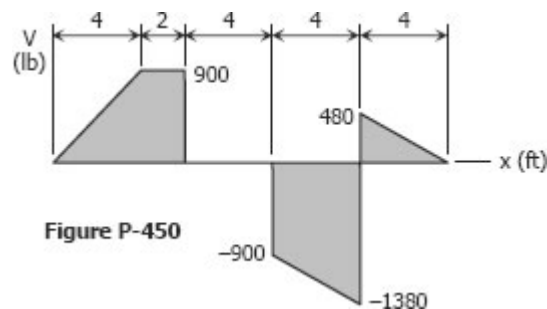
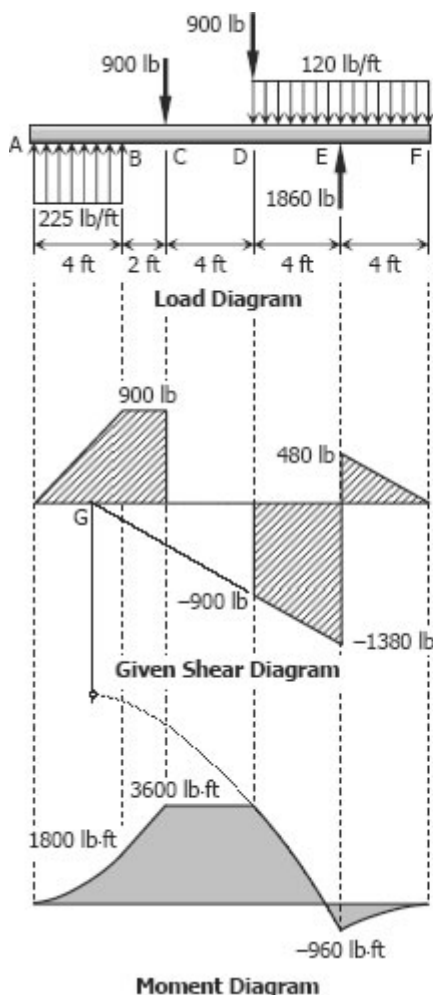

Figure P-450

Solution 450



To draw the Load Diagram

- (1) The shear diagram in AB is uniformly upward, thus the load is uniformly distributed upward at a magnitude of $900/4 = 225$ lb/ft. No load in segment BC.
- (2) A downward point force acts at point C with magnitude of 900 lb. No load in segment CD.
- (3) Another concentrated force is acting downward at D with a magnitude of 900 lb.
- (4) The load in DE is uniformly distributed downward at a magnitude of $(1380 - 900)/4 = 120$ lb/ft.
- (5) An upward load is concentrated at E with magnitude of $480 + 1380 = 1860$ lb.
- (6) $480/4 = 120$ lb/ft is distributed uniformly over the span EF.

To draw the Moment Diagram

- (1) $M_A = 0$
- (2) $M_B = M_A + \text{Area in shear diagram}$
 $M_B = 0 + \frac{1}{2}(4)(900) = 1800$ lb-ft
- (3) $M_C = M_B + \text{Area in shear diagram}$
 $M_C = 1800 + 900(2) = 3600$ lb-ft
- (4) $M_D = M_C + \text{Area in shear diagram}$
 $M_D = 3600 + 0 = 3600$ lb-ft
- (5) $M_E = M_D + \text{Area in shear diagram}$
 $M_E = 3600 - \frac{1}{2}(900 + 1380)(4)$
 $M_E = -960$ lb-ft
- (6) $M_F = M_E + \text{Area in shear diagram}$
 $M_F = -960 + \frac{1}{2}(480)(4) = 0$
- (7) The shape of moment diagram in AB is upward parabola with vertex at A, while linear in BC and horizontal in CD. For segment DE, the diagram is downward parabola with vertex at G. G is the point where the extended shear in DE intersects the line of zero shear.
- (8) The moment diagram in EF is a downward parabola with vertex at F.

Problem 451

Shear diagram as shown in Fig. P-451.

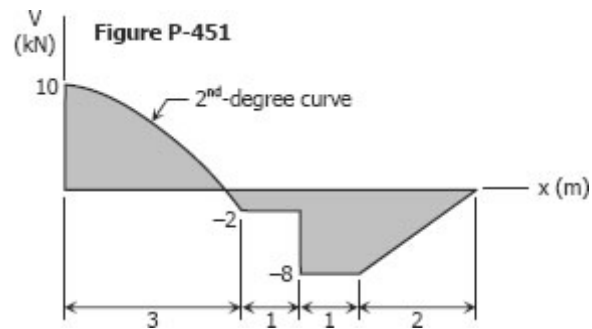

Solution 451

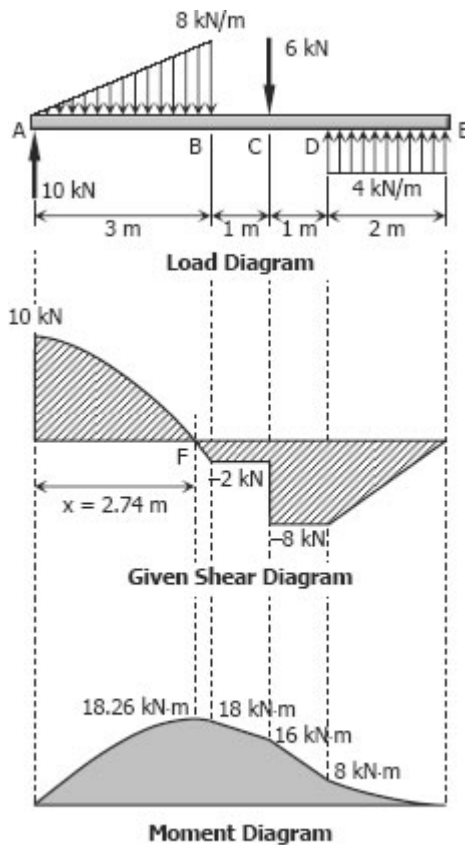

To draw the Load Diagram

- (1) Upward concentrated load at A is 10 kN.
- (2) The shear in AB is a 2nd-degree curve, thus the load in AB is uniformly varying. In this case, it is zero at A to $2(10 + 2)/3 = 8$ kN at B. No load in segment BC.
- (3) A downward point force is acting at C in a magnitude of $8 - 2 = 6$ kN.
- (4) The shear in DE is uniformly increasing, thus the load in DE is uniformly distributed and upward. This load is spread over DE at a magnitude of $8/2 = 4$ kN/m.

To draw the Moment Diagram

- (1) To find the location of zero shear, F:

$$x^2/10 = 3^2/(10 + 2)$$

$$x = 2.74 \text{ m}$$
- (2) $M_A = 0$
- (3) $M_F = M_A + \text{Area in shear diagram}$
 $M_F = 0 + 2/3 (2.74)(10) = 18.26 \text{ kN-m}$
- (4) $M_B = M_F + \text{Area in shear diagram}$
 $M_B = 18.26 - [1/3 (10 + 2)(3) - 1/3 (2.74)(10) - 10(3 - 2.74)]$
 $M_B = 18 \text{ kN-m}$
- (5) $M_C = M_B + \text{Area in shear diagram}$
 $M_C = 18 - 2(1) = 16 \text{ kN-m}$
- (6) $M_D = M_C + \text{Area in shear diagram}$
 $M_D = 16 - 8(1) = 8 \text{ kN-m}$
- (7) $M_E = M_D + \text{Area in shear diagram}$
 $M_E = 8 - 1/2 (2)(8) = 0$
- (8) The moment diagram in AB is a second degree curve, at BC and CD are linear and downward. For segment DE, the moment diagram is parabola open upward with vertex at E.

Moving Loads

From the previous section, we see that the maximum moment occurs at a point of zero shears. For beams loaded with concentrated loads, the point of zero shears usually occurs under a concentrated load and so the maximum moment.

Beams and girders such as in a bridge or an overhead crane are subject to moving concentrated loads, which are at fixed distance with each other. The problem here is to determine the moment under each load when each load is in a position to cause a maximum moment. The largest value of these moments governs the design of the beam.

SINGLE MOVING LOAD

For a single moving load, the maximum moment occurs when the load is at the midspan and the maximum shear occurs when the load is very near the support (usually assumed to lie over the support).

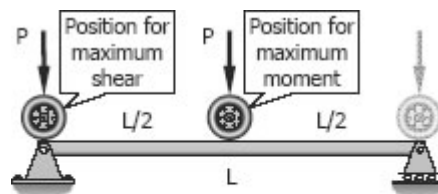

$$M_{\max} = \frac{PL}{4} \text{ and } V_{\max} = P$$

TWO MOVING LOADS

For two moving loads, the maximum shear occurs at the reaction when the larger load is over that support. The maximum moment is given by

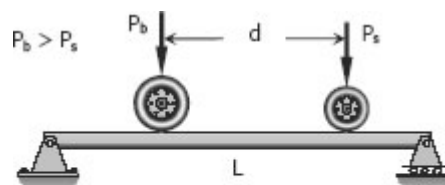

$$M_{\max} = \frac{(PL - P_s d)^2}{4PL}$$

where P_s is the smaller load, P_b is the bigger load, and P is the total load ($P = P_s + P_b$).

THREE OR MORE MOVING LOADS

In general, the bending moment under a particular load is a maximum when the center of the beam is midway between that load and the resultant of all the loads then on the span. With this rule, we compute the maximum moment under each load, and use the biggest of the moments for the design. Usually, the biggest of these moments occurs under the biggest load.

The maximum shear occurs at the reaction where the resultant load is nearest. Usually, it happens if the biggest load is over that support and as many a possible of the remaining loads are still on the span.

The maximum shear occurs at the reaction where the resultant load is nearest. Usually, it happens if the biggest load is over that support and as many a possible of the remaining loads are still on the span. In determining the largest moment and shear, it is sometimes necessary to check the condition when the bigger loads are on the span and the rest of the smaller loads are outside.

Solved Problems in Moving Loads

Problem 453

A truck with axle loads of 40 kN and 60 kN on a wheel base of 5 m rolls across a 10-m span. Compute the maximum bending moment and the maximum shearing force.

Solution 453

$$R = 40 + 60 = 100 \text{ kN}$$

$$xR = 40(5)$$

$$x = 200/R$$

$$x = 200/100$$

$$x = 2 \text{ m}$$

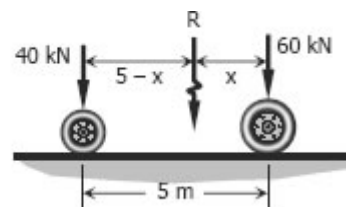

For maximum moment under 40 kN wheel:

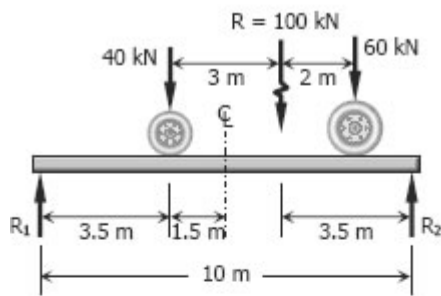

$$\sum M_{R2} = 0$$

$$10R_1 = 3.5(100)$$

$$R_1 = 35 \text{ kN}$$

$$M_{\text{To the left of 40 kN}} = 3.5R_1$$

$$M_{\text{To the left of 40 kN}} = 3.5(35)$$

$$M_{\text{To the left of 40 kN}} = 122.5 \text{ kN}\cdot\text{m}$$

For maximum moment under 60 kN wheel:

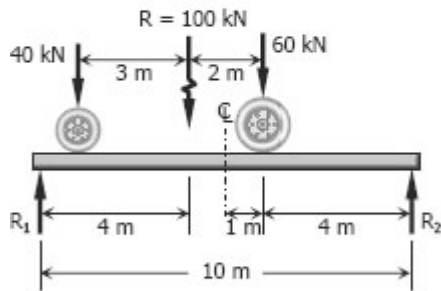

$$\sum M_{R1} = 0$$

$$10R_2 = 4(100)$$

$$R_2 = 40 \text{ kN}$$

$$M_{\text{To the right of 60 kN}} = 4R_2$$

$$M_{\text{To the right of 60 kN}} = 4(40)$$

$$M_{\text{To the right of 60 kN}} = 160 \text{ kN}\cdot\text{m}$$

Thus, $M_{\text{max}} = 160 \text{ kN}\cdot\text{m}$

The maximum shear will occur when the 60 kN is over a support.

$$\sum M_{R1} = 0$$

$$10R_2 = 100(8)$$

$$R_2 = 80 \text{ kN}$$

Thus, $V_{\text{max}} = 80 \text{ kN}$

Problem 454

Repeat Prob. 453 using axle loads of 30 kN and 50 kN on a wheel base of 4 m crossing an 8-m span.

Solution 454

$$R = 30 + 50 = 80 \text{ kN}$$

$$xR = 4(30)$$

$$x = 120/R$$

$$x = 120/80$$

$$x = 1.5 \text{ m}$$

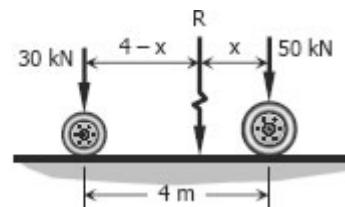

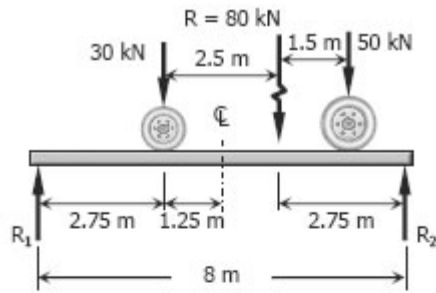

Maximum moment under 30 kN wheel:

$$\begin{aligned}\sum M_{R2} &= 0 \\ 8R_1 &= 2.75(80) \\ R_1 &= 27.5 \text{ kN}\end{aligned}$$

$$\begin{aligned}M_{\text{To the left of 30 kN}} &= 2.75R_1 \\ M_{\text{To the left of 30 kN}} &= 2.75(27.5) \\ M_{\text{To the left of 30 kN}} &= 75.625 \text{ kN}\cdot\text{m}\end{aligned}$$

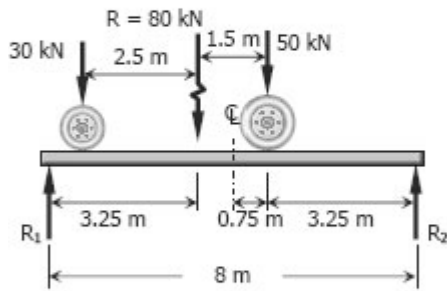

Maximum moment under 50 kN wheel:

$$\begin{aligned}\sum M_{R1} &= 0 \\ 8R_2 &= 3.25(80) \\ R_2 &= 32.5 \text{ kN}\end{aligned}$$

$$\begin{aligned}M_{\text{To the right of 50 kN}} &= 3.25R_2 \\ M_{\text{To the right of 50 kN}} &= 3.25(32.5) \\ M_{\text{To the right of 50 kN}} &= 105.625 \text{ kN}\cdot\text{m}\end{aligned}$$

Thus, $M_{\max} = 105.625 \text{ kN}\cdot\text{m}$

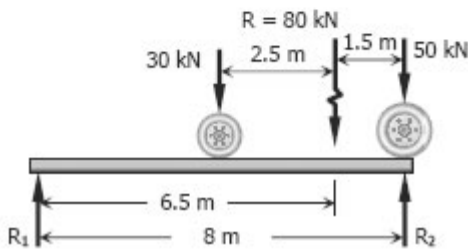

The maximum shear will occur when the 50 kN is over a support.

$$\begin{aligned}\sum M_{R1} &= 0 \\ 8R_2 &= 6.5(80) \\ R_2 &= 65 \text{ kN}\end{aligned}$$

Thus, $V_{\max} = 65 \text{ kN}$

Problem 455

A tractor weighing 3000 lb, with a wheel base of 9 ft, carries 1800 lb of its load on the rear wheels. Compute the maximum moment and maximum shear when crossing a 14 ft-span.

Solution 455

$$\begin{aligned}R &= W_r + W_f \\ 3000 &= 1800 + W_f \\ W_f &= 1200 \text{ lb}\end{aligned}$$

$$\begin{aligned}Rx &= 9W_f \\ 3000x &= 9(1200) \\ x &= 3.6 \text{ ft}\end{aligned}$$

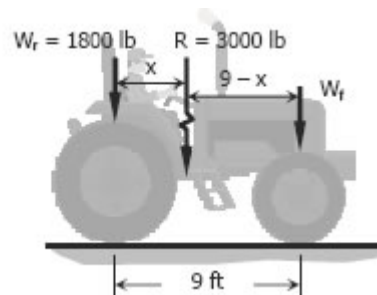

$$9 - x = 5.4 \text{ ft}$$

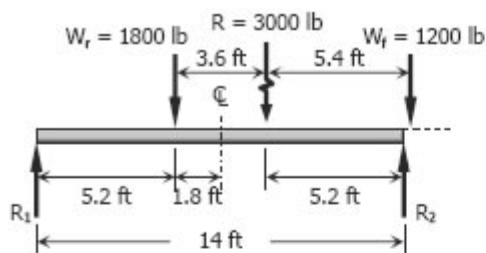

When the midspan is midway between W_r and R , the front wheel W_f will be outside the span (see figure). In this case, only the rear wheel $W_r = 1800 \text{ lb}$ is the load. The maximum moment for this condition is when the load is at the midspan.

$$R_1 = R_2 = \frac{1}{2} (1800)$$

$$R_1 = 900 \text{ lb}$$

Maximum moment under W_r ,

$$M_{\text{To the left of rear wheel}} = 7R_1$$

$$M_{\text{To the left of rear wheel}} = 7(900)$$

$$M_{\text{To the left of rear wheel}} = 6300 \text{ lb-ft}$$

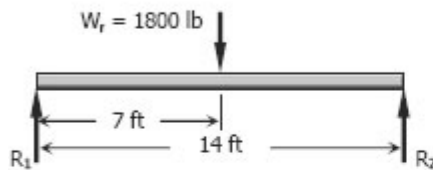

Maximum moment under W_f

$$\sum M_{R_1} = 0$$

$$14R_2 = 4.3R$$

$$14R_2 = 4.3(3000)$$

$$R_2 = 921.43 \text{ lb}$$

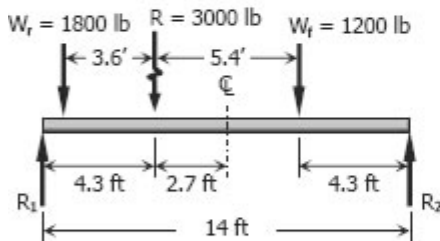

$$M_{\text{To the right of front wheel}} = 4.3R_2$$

$$M_{\text{To the right of front wheel}} = 4.3(921.43)$$

$$M_{\text{To the right of front wheel}} = 3962.1 \text{ lb-ft}$$

Thus, $M_{\text{max}} = M_{\text{To the left of rear wheel}}$

$$M_{\text{max}} = 6300 \text{ lb-ft}$$

The maximum shear will occur when the rear wheel (wheel of greater load) is directly over the support.

$$\sum M_{R_2} = 0$$

$$14R_1 = 10.4R$$

$$14R_1 = 10.4(3000)$$

$$R_1 = 2228.57 \text{ lb}$$

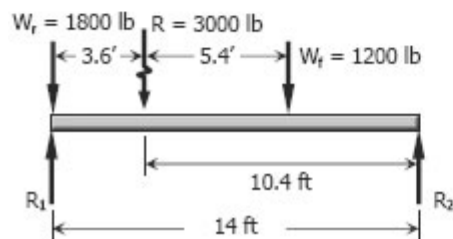

Thus, $V_{\text{max}} = 2228.57 \text{ lb}$

Problem 456

Three wheel loads roll as a unit across a 44-ft span. The loads are $P_1 = 4000$ lb and $P_2 = 8000$ lb separated by 9 ft, and $P_3 = 6000$ lb at 18 ft from P_2 . Determine the maximum moment and maximum shear in the simply supported span.

Solution 456

$$R = P_1 + P_2 + P_3$$

$$R = 4^k + 8^k + 6^k$$

$$R = 18 \text{ kips}$$

$$R = 18,000 \text{ lbs}$$

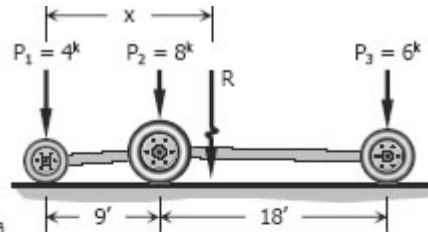

$$xR = 9P_2 + (9 + 18)P_3$$

$$x(18) = 9(8) + (9 + 18)(6)$$

$$x = 13 \text{ ft} \rightarrow \text{the resultant } R \text{ is } 13 \text{ ft from } P_1$$

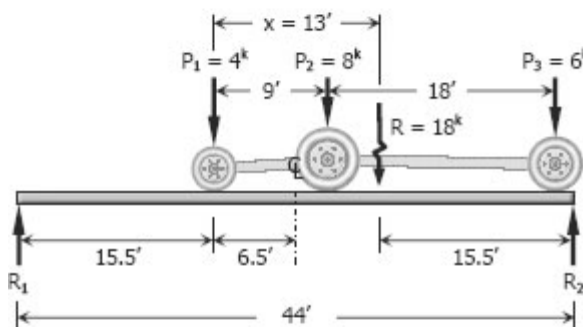

Maximum moment under P_1

$$\sum M_{R2} = 0$$

$$44R_1 = 15.5R$$

$$44R_1 = 15.5(18)$$

$$R_1 = 6.34091 \text{ kips}$$

$$R_1 = 6,340.91 \text{ lbs}$$

$$M_{\text{To the left of } P_1} = 15.5R_1$$

$$M_{\text{To the left of } P_1} = 15.5(6340.91)$$

$$M_{\text{To the left of } P_1} = 98,284.1 \text{ lb-ft}$$

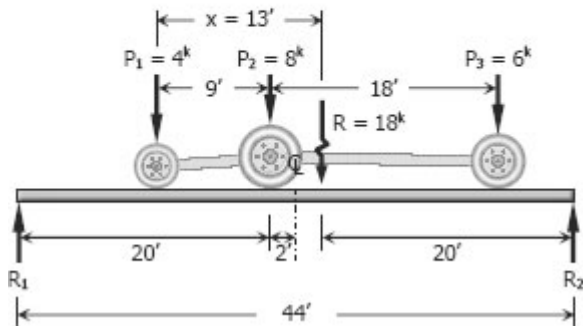

Maximum moment under P_2

$$\sum M_{R2} = 0$$

$$44R_1 = 20R$$

$$44R_1 = 20(18)$$

$$R_1 = 8.18182 \text{ kips}$$

$$R_1 = 8,181.82 \text{ lbs}$$

$$M_{\text{To the left of } P_2} = 20R_1 - 9P_1$$

$$M_{\text{To the left of } P_2} = 20(8,181.82) - 9(4000)$$

$$M_{\text{To the left of } P_2} = 127,636.4 \text{ lb-ft}$$

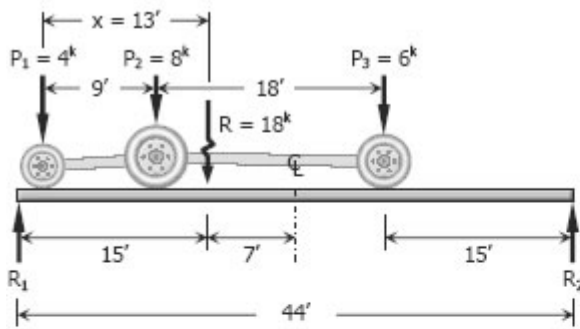

Maximum moment under P_3

$$\begin{aligned} \sum R_1 &= 0 \\ 44R_2 &= 15R \\ 44R_2 &= 15(18) \\ R_2 &= 6.13636 \text{ kips} \\ R_2 &= 6,136.36 \text{ lbs} \end{aligned}$$

$$\begin{aligned} M_{\text{To the right of } P_3} &= 15R_2 \\ M_{\text{To the right of } P_3} &= 15(6,136.36) \\ M_{\text{To the right of } P_3} &= 92,045.4 \text{ lb}\cdot\text{ft} \end{aligned}$$

$$\begin{aligned} \text{Thus, } M_{\text{max}} &= M_{\text{To the left of } P_2} \\ &= 127,636.4 \text{ lb}\cdot\text{ft} \end{aligned}$$

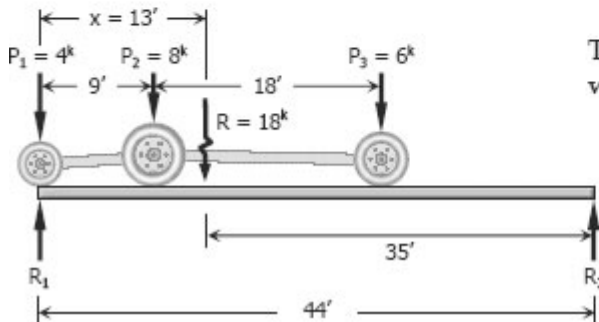

The maximum shear will occur when P_1 is over the support.

$$\begin{aligned} \sum M_{R_2} &= 0 \\ 44R_1 &= 35R \\ 44R_1 &= 35(18) \\ R_1 &= 14.3182 \text{ kips} \\ R_1 &= 14,318.2 \text{ lbs} \end{aligned}$$

$$\text{Thus, } V_{\text{max}} = 14,318.2 \text{ lbs}$$

Problem 457

A truck and trailer combination crossing a 12-m span has axle loads of 10, 20, and 30 kN separated respectively by distances of 3 and 5 m. Compute the maximum moment and maximum shear developed in the span.

Solution 457

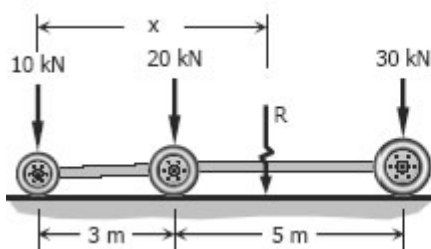

$$\begin{aligned} R &= 10 + 20 + 30 \\ R &= 60 \text{ kN} \end{aligned}$$

$$\begin{aligned} xR &= 3(20) + 8(30) \\ x(60) &= 3(20) + 8(30) \\ x &= 5 \text{ m} \end{aligned}$$

Maximum moment under 10 kN

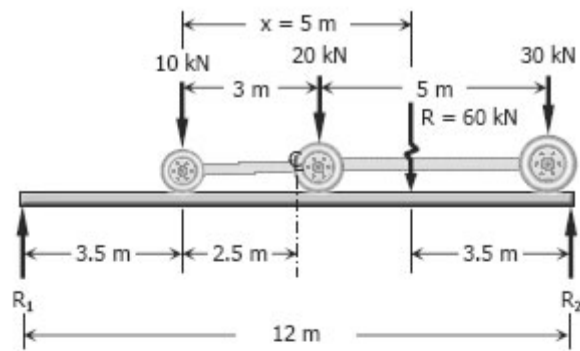

$$\begin{aligned}\sum M_{R2} &= 0 \\ 12R_1 &= 3.5R \\ 12R_1 &= 3.5(60) \\ 12R_1 &= 210 \\ R_1 &= 12.7 \text{ kN}\end{aligned}$$

$$\begin{aligned}M_{\text{To the left of 10 kN}} &= 3.5R_1 \\ &= 3.5(12.7) \\ &= 61.25 \text{ kN}\cdot\text{m}\end{aligned}$$

Maximum moment under 20 kN

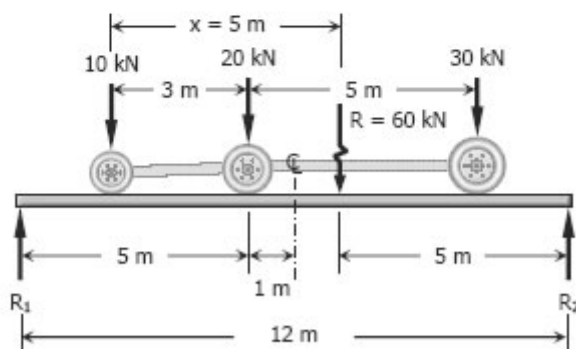

$$\begin{aligned}\sum M_{R2} &= 0 \\ 12R_1 &= 5R \\ 12R_1 &= 5(60) \\ R_1 &= 25 \text{ kN}\end{aligned}$$

$$\begin{aligned}
 M_{\text{To the left of 20 kN}} &= 5R_1 - 3(10) \\
 &= 5(25) - 30 \\
 &= 95 \text{ kN}\cdot\text{m}
 \end{aligned}$$

When the centerline of the beam is midway between reaction $R = 60 \text{ kN}$ and 30 kN , the 10 kN comes off the span.

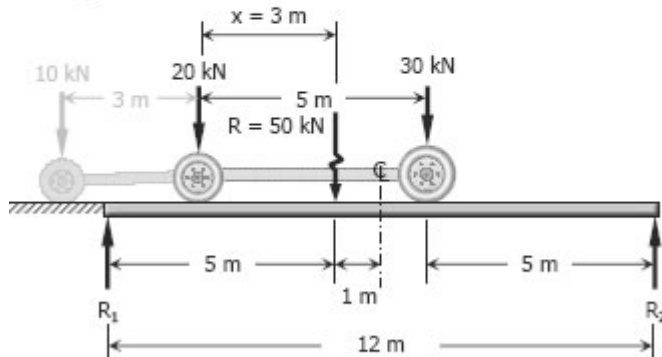

$$\begin{aligned}
 R &= 20 + 30 \\
 R &= 50 \text{ kN}
 \end{aligned}$$

$$\begin{aligned}
 xR &= 5(30) \\
 x(50) &= 150 \\
 x &= 3 \text{ m from 20 kN}
 \end{aligned}$$

$$\begin{aligned}
 \sum M_{R1} &= 0 \\
 12R_2 &= 5R \\
 12R_2 &= 5(50) \\
 R_2 &= 20.83 \text{ kN}
 \end{aligned}$$

$$\begin{aligned}
 M_{\text{To the right of 30 kN}} &= 5R_2 \\
 &= 5(20.83) \\
 &= 104.17 \text{ kN}\cdot\text{m}
 \end{aligned}$$

Thus, the maximum moment will occur when only the 20 kN and 30 kN loads are on the span.

$$\begin{aligned}
 M_{\text{max}} &= M_{\text{To the right of 30 kN}} \\
 M_{\text{max}} &= \mathbf{104.17 \text{ kN}\cdot\text{m}}
 \end{aligned}$$

The maximum shear will occur when the three loads are on the span and the 30 kN load is directly over the support.

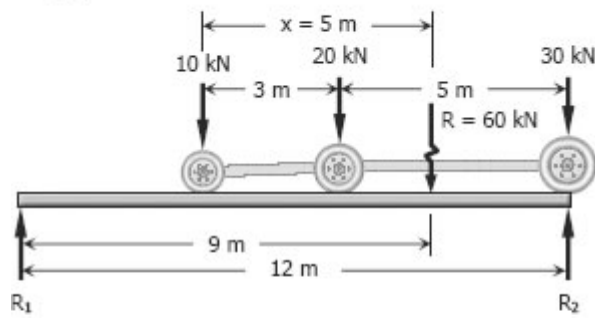

$$\begin{aligned}\Sigma M_{R_1} &= 0 \\ 12R_2 &= 9R \\ 12R_2 &= 9(60) \\ R_2 &= 45 \text{ kN}\end{aligned}$$

Thus, $V_{\max} = 45$ kN

Stresses in Beams

Forces and couples acting on the beam cause bending (flexural stresses) and shearing stresses on any cross section of the beam and deflection perpendicular to the longitudinal axis of the beam. If couples are applied to the ends of the beam and no forces act on it, the bending is said to be pure bending. If forces produce the bending, the bending is called ordinary bending.

ASSUMPTIONS

In using the following formulas for flexural and shearing stresses, it is assumed that a plane section of the beam normal to its longitudinal axis prior to loading remains plane after the forces and couples have been applied, and that the beam is initially straight and of uniform cross section and that the moduli of elasticity in tension and compression are equal.

Flexure Formula

Stresses caused by the bending moment are known as flexural or bending stresses.

Consider a beam to be loaded as shown.

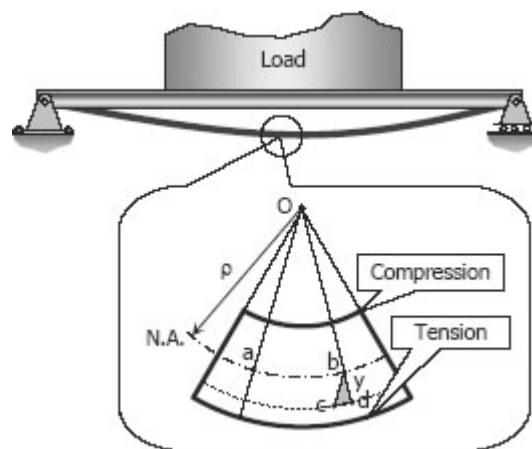

Consider a fiber at a distance y from the neutral axis, because of the beam's curvature, as the effect of bending moment, the fiber is stretched by an amount of cd . Since the curvature of the beam is very small, bcd and Oba are considered as similar triangles. The strain on this fiber is

$$\varepsilon = \frac{cd}{ab} = \frac{y}{\rho}$$

By Hooke's law, $\varepsilon = \sigma / E$, then

$$\frac{\sigma}{E} = \frac{y}{\rho}; \sigma = \frac{y}{\rho} E$$

which means that the stress is proportional to the distance y from the neutral axis.

For this chapter, the notation f_b will be used instead of σ , to denote flexural stresses.

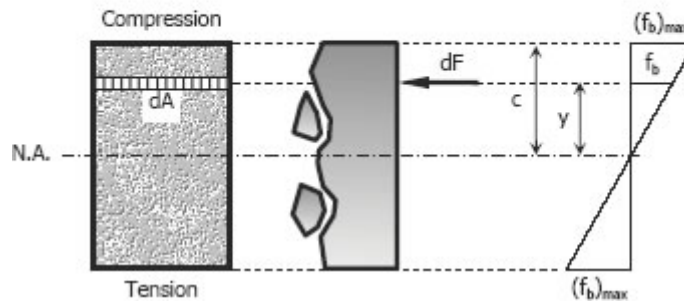

Considering a differential area dA at a distance y from N.A., the force acting over the area is

$$dF = f_b dA = \frac{y}{\rho} E dA = \frac{E}{\rho} y dA$$

The resultant of all the elemental moment about N.A. must be equal to the bending moment on the section.

$$M = \int y dF = \int y \frac{E}{\rho} y dA$$

$$M = \frac{E}{\rho} \int y^2 dA$$

but $\int y^2 dA = I$, then

$$M = \frac{EI}{\rho} \text{ or } \rho = \frac{EI}{M}$$

substituting $\rho = Ey / f_b$

$$\frac{Ey}{f_b} = \frac{EI}{M}$$

then

$$f_b = \frac{My}{I}$$

and

$$(f_b)_{\max} = \frac{Mc}{I}$$

The bending stress due to beams curvature is

$$f_b = \frac{Mc}{I} = \frac{EI}{\rho} \frac{c}{I}$$

$$f_b = \frac{Ec}{\rho}$$

The beam curvature is:

$$k = 1 / \rho$$

where ρ is the radius of curvature of the beam in mm (in), M is the bending moment in N·mm (lb·in), f_b is the flexural stress in MPa (psi), I is the centroidal moment of inertia in mm⁴ (in⁴), and c is the distance from the neutral axis to the outermost fiber in mm (in).

SECTION MODULUS

In the formula

$$(f_b)_{\max} = \frac{Mc}{I} = \frac{M}{I/c}$$

the ratio I/c is called the section modulus and is usually denoted by S with units of mm³ (in³). The maximum bending stress may then be written as

$$(f_b)_{\max} = \frac{M}{S}$$

This form is convenient because the values of S are available in handbooks for a wide range of standard structural shapes.

Solved Problems in Flexure Formula

Problem 503

A cantilever beam, 50 mm wide by 150 mm high and 6 m long, carries a load that varies uniformly from zero at the free end to 1000 N/m at the wall. (a) Compute the magnitude and location of the maximum flexural stress. (b) Determine the type and magnitude of the stress in a fiber 20 mm from the top of the beam at a section 2 m from the free end.

Solution 503

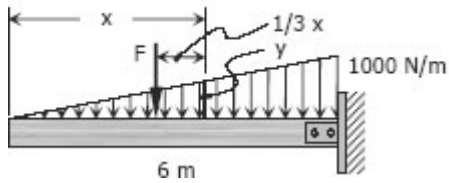

$$M = F\left(\frac{1}{3}x\right)$$

$$\frac{y}{x} = \frac{1000}{6}$$

$$y = \frac{500}{3}x$$

$$F = \frac{1}{2}xy$$

$$F = \frac{1}{2}x\left(\frac{500}{3}x\right)$$

$$F = \frac{250}{3}x^2$$

thus $M = \frac{250}{3}x^2 \left(\frac{1}{3}x\right)$

$$M = \frac{250}{9}x^3$$

- (a) The maximum moment occurs at the support (the wall) or at $x = 6$ m.

$$M = \frac{250}{9}x^3 = \frac{250}{9}(6^3)$$

$$= 6000 \text{ N}\cdot\text{m}$$

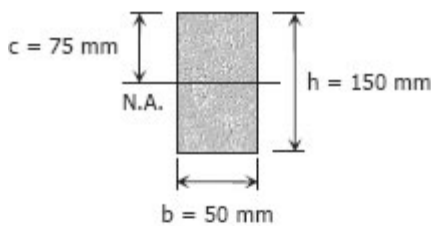

$$(f_b)_{\max} = \frac{Mc}{I} = \frac{Mc}{\frac{bh^3}{12}}$$

$$(f_b)_{\max} = \frac{6000(1000)(75)}{\frac{50(150)^3}{12}}$$

$$(f_b)_{\max} = 32 \text{ MPa}$$

- (b) At a section 2 m from the free end or at $x = 2$ m at fiber 20 mm from the top of the beam:

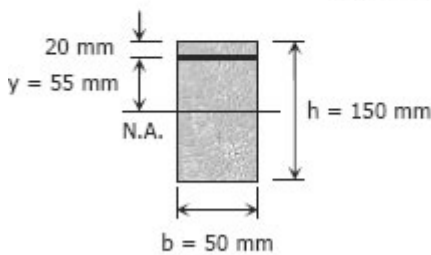

$$M = \frac{250}{9}x^3 = \frac{250}{9}(2)^3$$

$$M = \frac{2000}{9} \text{ N}\cdot\text{m}$$

$$f_b = \frac{My}{I} = \frac{\left(\frac{2000}{9}\right)(1000)(55)}{\frac{50(150)^3}{12}}$$

$$f_b = 0.8691 \text{ MPa} = 869.1 \text{ kPa}$$

Problem 504

A simply supported beam, 2 in wide by 4 in high and 12 ft long is subjected to a concentrated load of 2000 lb at a point 3 ft from one of the supports. Determine the maximum fiber stress and the stress in a fiber located 0.5 in from the top of the beam at midspan.

Solution 504

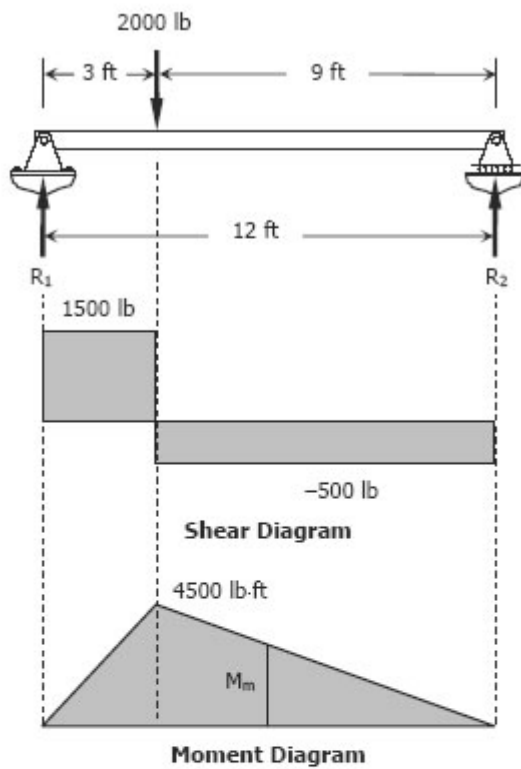

$$\begin{aligned} \Sigma M_{R2} &= 0 \\ 12R_1 &= 9(2000) \\ R_1 &= 1500 \text{ lb} \end{aligned}$$

$$\begin{aligned} \Sigma M_{R1} &= 0 \\ 12R_2 &= 3(2000) \\ R_2 &= 500 \text{ lb} \end{aligned}$$

Maximum fiber stress:

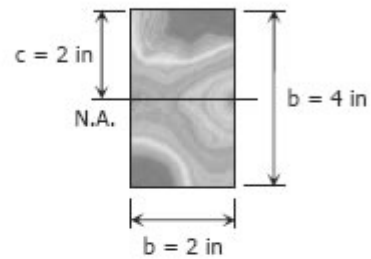

$$(f_b)_{\max} = \frac{Mc}{I} = \frac{4500(12)(2)}{\frac{2(4)^3}{12}}$$

$$(f_b)_{\max} = 10,125 \text{ psi}$$

Stress in a fiber located 0.5 in from the top of the beam at midspan:

$$\begin{aligned} \frac{M_m}{6} &= \frac{4500}{9} \\ M_m &= 3000 \text{ lb-ft} \end{aligned}$$

$$\begin{aligned} f_b &= \frac{My}{I} \\ f_b &= \frac{3000(12)(1.5)}{\frac{2(4^3)}{12}} \\ f_b &= 5,062.5 \text{ psi} \end{aligned}$$

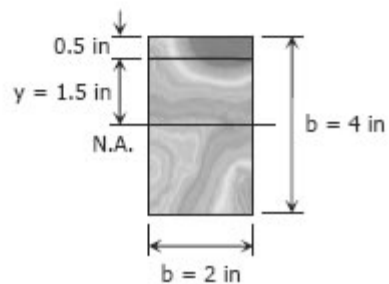

Problem 505

A high strength steel band saw, 20 mm wide by 0.80 mm thick, runs over pulleys 600 mm in diameter. What maximum flexural stress is developed? What minimum diameter pulleys can be used without exceeding a flexural stress of 400 MPa? Assume $E = 200$ GPa.

Solution 505

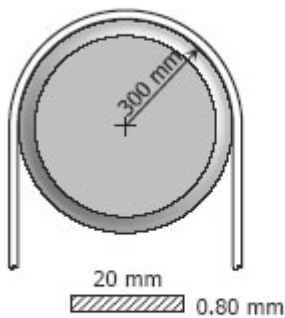

Flexural stress developed:

$$M = \frac{EI}{\rho}$$

$$f_b = \frac{Mc}{I} = \frac{(EI/\rho)c}{I}$$

$$f_b = \frac{Ec}{\rho} = \frac{200000(0.80/2)}{300}$$

$$f_b = 266.67 \text{ MPa}$$

Minimum diameter of pulley:

$$f_b = \frac{Ec}{\rho}$$

$$400 = \frac{200000(0.80/2)}{\rho}$$

$$\rho = 200 \text{ mm}$$

diameter, $d = 400 \text{ mm}$

Problem 506

A flat steel bar, 1 inch wide by 1/4 inch thick and 40 inches long, is bent by couples applied at the ends so that the midpoint deflection is 1.0 inch. Compute the stress in the bar and the magnitude of the couples. Use $E = 29 \times 10^6$ psi.

Solution 506

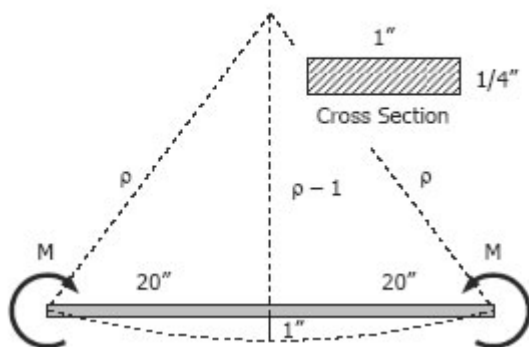

$$(\rho - 1)^2 + 20^2 = \rho^2$$

$$\rho^2 - 2\rho + 1 + 400 = \rho^2$$

$$2\rho = 401$$

$$\rho = 200.5 \text{ in}$$

$$M = \frac{EI}{\rho}$$

$$f_b = \frac{Mc}{I} = \frac{(EI/\rho)c}{I}$$

$$f_b = \frac{Ec}{\rho} = \frac{(29 \times 10^6)(1/8)}{200.5}$$

$$f_b = 18\,079.8 \text{ psi}$$

$$f_b = 18.1 \text{ ksi}$$

$$M = \frac{EI}{\rho} = \frac{(29 \times 10^6) \frac{1(1/4)^3}{12}}{200.5}$$

$$M = 188.3 \text{ lb}\cdot\text{in}$$

Problem 507

In a laboratory test of a beam loaded by end couples, the fibers at layer AB in Fig. P-507 are found to increase 60×10^{-3} mm whereas those at CD decrease 100×10^{-3} mm in the 200-mm-gage length. Using $E = 70$ GPa, determine the flexural stress in the top and bottom fibers.

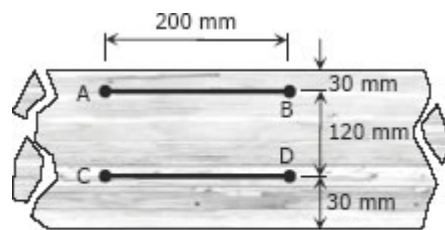
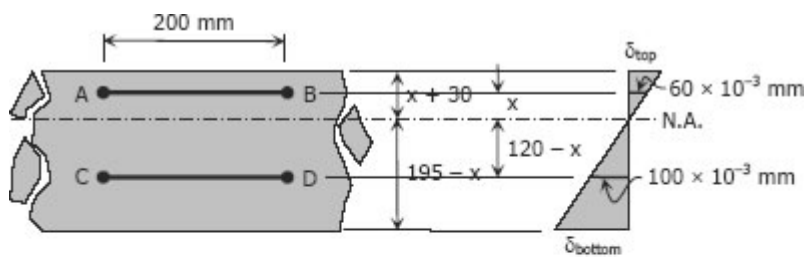

Figure P-507

Solution 507



$$\frac{x}{60 \times 10^{-3}} = \frac{120 - x}{100 \times 10^{-3}}$$

$$x = 0.6(120 - x)$$

$$x + 0.6x = 0.6(120)$$

$$1.6x = 72$$

$$x = 45 \text{ mm}$$

$$\frac{\delta_{top}}{x+30} = \frac{60 \times 10^{-3}}{x}$$

$$\delta_{top} = \frac{60 \times 10^{-3}}{45} (45+30)$$

$$\delta_{top} = 0.1 \text{ mm lengthening}$$

$$\frac{\delta_{bottom}}{195-x} = \frac{100 \times 10^{-3}}{120-x}$$

$$\delta_{bottom} = \frac{100 \times 10^{-3}}{120-45} (195-45)$$

$$\delta_{bottom} = 0.2 \text{ mm shortening}$$

From Hooke's Law

$$f_v = E\varepsilon$$

$$f_v = \frac{E\delta}{L}$$

$$(f_v)_{top} = \frac{70000(0.1)}{200}$$

$$= 35 \text{ MPa tension}$$

$$(f_v)_{bottom} = \frac{70000(0.2)}{200}$$

$$= 70 \text{ MPa compression}$$

Problem 508

Determine the minimum height h of the beam shown in Fig. P-508 if the flexural stress is not to exceed 20 MPa.

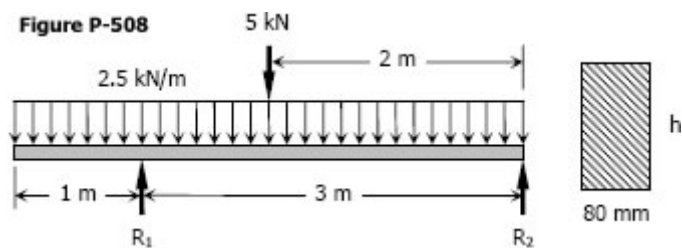

Solution 508

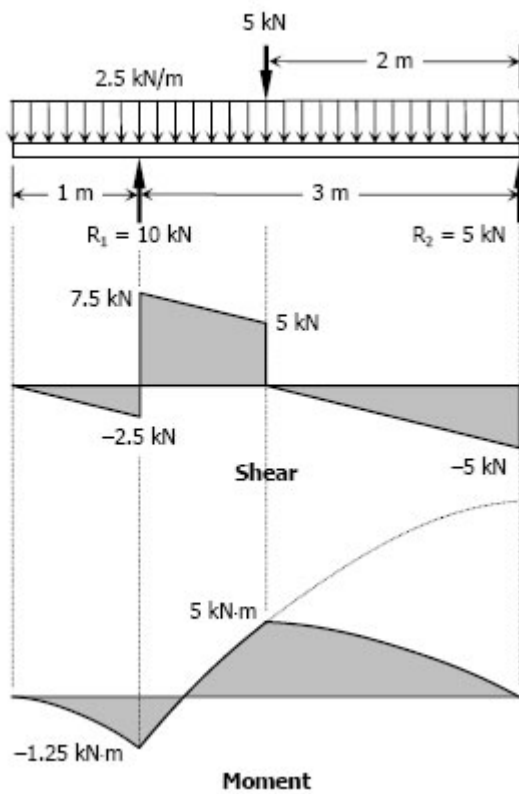

$$\begin{aligned} \Sigma M_{R2} &= 0 \\ 3R_1 &= 2(5) + 2(2.5)(4) \\ R_1 &= 10 \text{ kN} \end{aligned}$$

$$\begin{aligned} \Sigma M_{R1} &= 0 \\ 3R_2 &= 1(5) + 1(2.5)(4) \\ R_2 &= 5 \text{ kN} \end{aligned}$$

$$f_b = \frac{Mc}{I}$$

Where:

$$\begin{aligned} f_b &= 20 \text{ MPa} \\ M &= 5 \text{ kN}\cdot\text{m} \\ &= 5(1000)^2 \text{ N}\cdot\text{mm} \\ c &= \frac{1}{2}h \\ I &= \frac{bh^3}{12} = \frac{80h^3}{12} \\ &= \frac{20}{3}h^3 \end{aligned}$$

Thus,

$$20 = \frac{5(1000)^2 (\frac{1}{2}h)}{\frac{20}{3}h^3}$$

$$\begin{aligned} h^2 &= 18750 \\ h &= 137 \text{ mm} \end{aligned}$$

Problem 509

A section used in aircraft is constructed of tubes connected by thin webs as shown in Fig. P-509. Each tube has a cross-sectional area of 0.20 in². If the average stress in the tubes is no to exceed 10 ksi, determine the total uniformly distributed load that can be supported in a simple span 12 ft long. Neglect the effect of the webs.

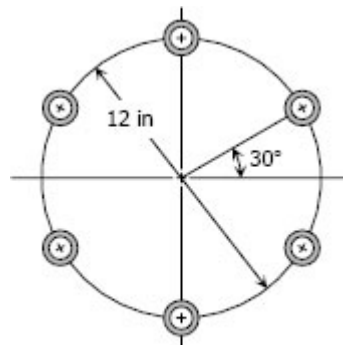
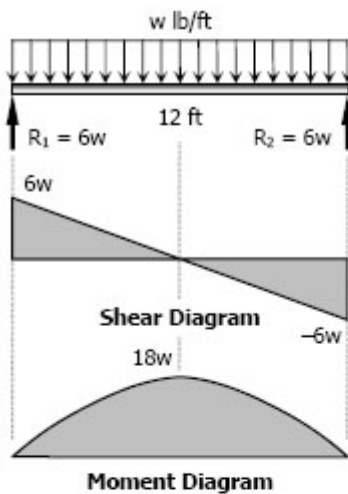

Figure P-509

Solution 509



$$R_1 = R_2 = \frac{1}{2} (12)(w)$$

$$R_1 = R_2 = 6w$$

$$f_b = 10 \text{ ksi} = 10,000 \text{ psi}$$

$$M = 18w \text{ lb-ft}$$

$$c = 6$$

Centroidal moment of inertia of one tube:

$$A = \pi r^2 = 0.20$$

$r = 0.2523 \text{ in} \rightarrow$ hollow portion of the tube was neglected

$$\bar{I}_x = \frac{\pi r^4}{4} = \frac{\pi(0.2523)^4}{4}$$

$$\bar{I}_x = 0.0032 \text{ in}^4$$

Moment of inertia at the center of the section:

$$d_1 = 6 \sin 30^\circ = 3 \text{ in}$$

$$I_1 = \bar{I}_x + A d_1^2$$

$$I_1 = 0.0032 + 0.2(3^2)$$

$$I_1 = 1.8 \text{ in}^4$$

$$I_2 = \bar{I}_x + A d_2^2$$

$$I_2 = 0.0032 + 0.2(6^2)$$

$$I_2 = 7.2 \text{ in}^4$$

$$I = 4I_1 + 2I_2 = 4(1.8) + 2(7.2)$$

$$I = 21.6 \text{ in}^4$$

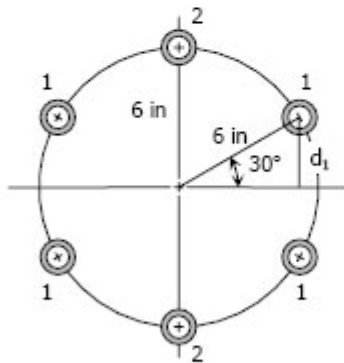

$$f_b = \frac{Mc}{I}$$

$$10,000 = \frac{18w(12)(6)}{21.6}$$

$$w = 166.7 \text{ lb/ft}$$

Problem 510

A 50-mm diameter bar is used as a simply supported beam 3 m long. Determine the largest uniformly distributed load that can be applied over the right two-thirds of the beam if the flexural stress is limited to 50 MPa.

Solution 510

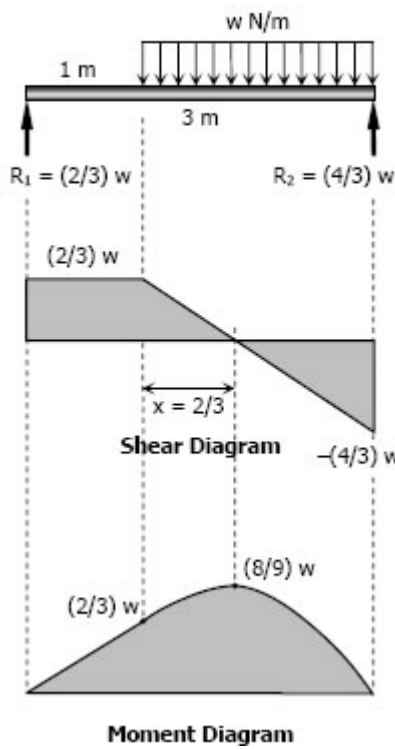

$$\begin{aligned} \sum M_{R1} &= 0 \\ 3R_2 &= 2w(2) \\ R_2 &= \frac{4}{3}w \end{aligned}$$

$$\begin{aligned} \sum M_{R2} &= 0 \\ 3R_1 &= 2w(1) \\ R_1 &= \frac{2}{3}w \end{aligned}$$

$$(f_b)_{\max} = \frac{Mc}{I}$$

where $(f_b)_{\max} = 50 \text{ MPa}$

$$M = \frac{8}{9}w \text{ N}\cdot\text{m}$$

$$c = 25 \text{ mm}$$

$$I = \frac{\pi r^4}{4} = \frac{\pi(25)^4}{4}$$

$$I = 97656.25\pi \text{ mm}^4$$

$$50 = \frac{\frac{8}{9}w(1000)(25)}{97656.25\pi}$$

$$w = 690.29 \text{ N/m}$$

Problem 511

A simply supported rectangular beam, 2 in wide by 4 in deep, carries a uniformly distributed load of 80 lb/ft over its entire length. What is the maximum length of the beam if the flexural stress is limited to 3000 psi?

Solution 511

By symmetry:

$$R_1 = R_2 = \frac{1}{2}(80L)$$

$$R_1 = R_2 = 40L$$

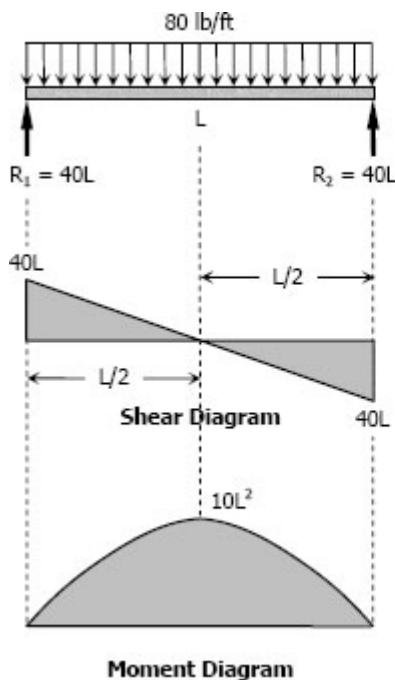

$$(f_b)_{\max} = \frac{Mc}{I}$$

where $(f_b)_{\max} = 3000 \text{ psi}$

$$M = 10L^2 \text{ lb}\cdot\text{ft}$$

$$c = h/2 = 2 \text{ in}$$

$$I = \frac{bh^3}{12} = \frac{2(4)^3}{12}$$

$$= \frac{32}{3} \text{ in}^4$$

$$3000 = \frac{10L^2(12)(2)}{32/3}$$

$$L = 11.55 \text{ ft}$$

Problem 512

The circular bar 1 inch in diameter shown in Fig. P-512 is bent into a semicircle with a mean radius of 2 ft. If $P = 400$ lb and $F = 200$ lb, compute the maximum flexural stress developed in section a-a. Neglect the deformation of the bar.

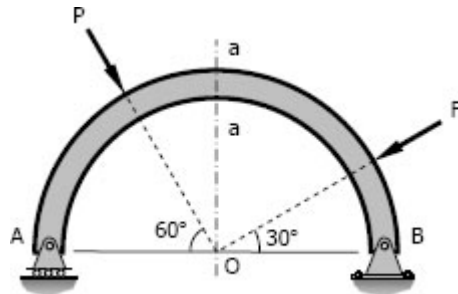
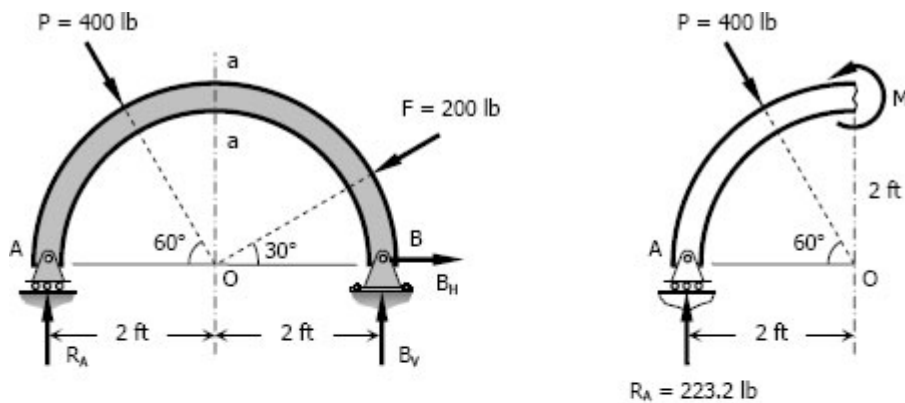

Figure P-512

Solution 512

$$\begin{aligned} \sum M_B = 0 \\ 4R_A = 2(400 \sin 60^\circ) + 2(200 \sin 30^\circ) \\ R_A = 223.2 \text{ lb} \end{aligned}$$



$$\begin{aligned} M = 2(223.2) - 2(400 \cos 60^\circ) \\ M = 46.4 \text{ lb-ft} \end{aligned}$$

$$\begin{aligned} (f_b)_{\max} &= \frac{Mc}{I} = \frac{Mr}{\pi r^4 / 4} \\ (f_b)_{\max} &= \frac{4M}{\pi r^3} = \frac{4(46.4)(12)}{\pi(0.5)^3} \\ (f_b)_{\max} &= 5671.52 \text{ psi} \end{aligned}$$

Problem 513

A rectangular steel beam, 2 in wide by 3 in deep, is loaded as shown in Fig. P-513. Determine the magnitude and the location of the maximum flexural stress.

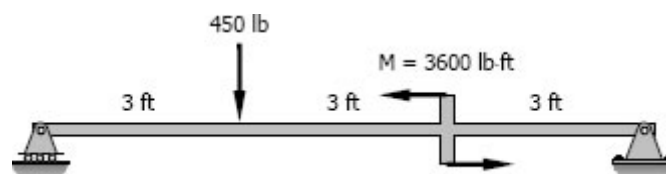
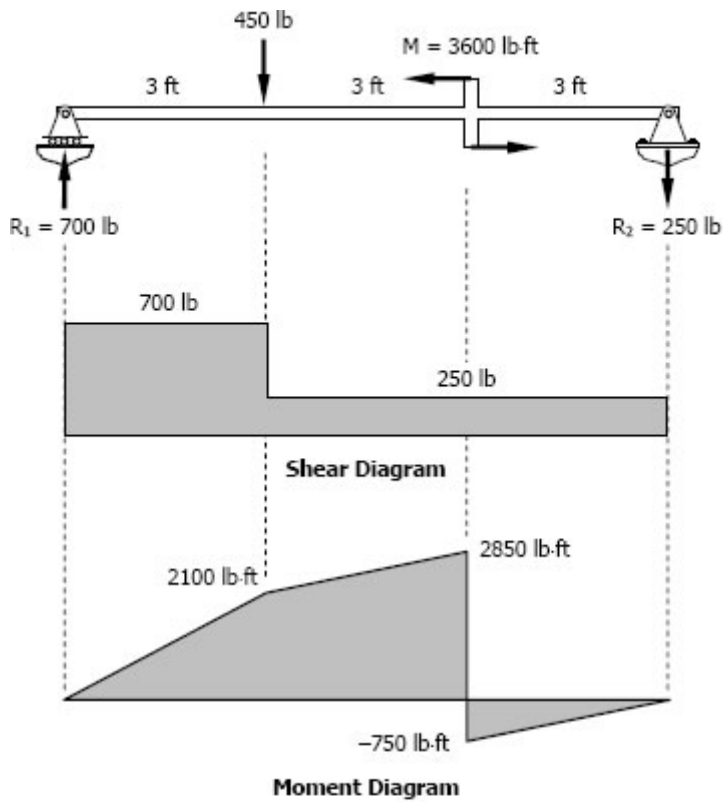

Figure P-513

Solution 513

$$\begin{aligned}\Sigma M_{R_2} &= 0 \\ 9R_1 &= 6(450) + 3600 \\ R_1 &= 700 \text{ lb}\end{aligned}$$

$$\begin{aligned}\Sigma M_{R_1} &= 0 \\ 9R_2 + 3(450) &= 3600 \\ R_2 &= 250 \text{ lb}\end{aligned}$$



$$(f_b)_{\max} = \frac{Mc}{I}$$

where $M = 2850$ lb-ft
 $c = h/2 = 3/2$
 $= 1.5$ in

$$\begin{aligned}I &= \frac{bh^3}{12} = \frac{2(3^3)}{12} \\ &= 4.5 \text{ in}^4\end{aligned}$$

$$(f_b)_{\max} = \frac{2850(12)(1.5)}{4.5}$$

$$(f_b)_{\max} = 11400 \text{ psi @ 3 ft from right support}$$

Problem 514

The right-angled frame shown in Fig. P-514 carries a uniformly distributed loading equivalent to 200 N for each horizontal projected meter of the frame; that is, the total load is 1000 N. Compute the maximum flexural stress at section a-a if the cross-section is 50 mm square.

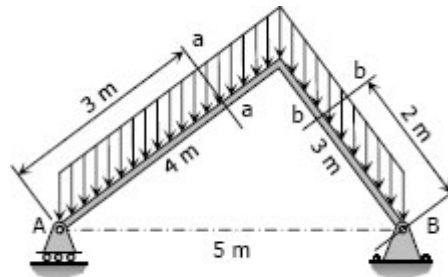
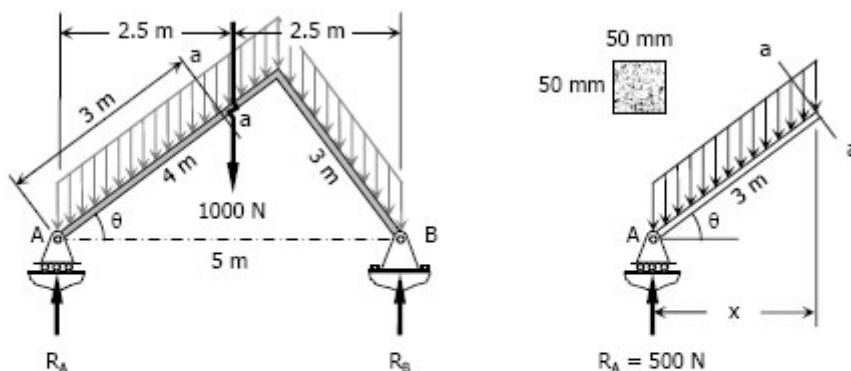

Figure P-514 and P-515

Solution 514

By symmetry
 $R_A = 500 \text{ N}$
 $R_B = 500 \text{ N}$



At section a-a:

$$\cos \theta = \frac{x}{3} = \frac{4}{5}$$

$$x = 2.4 \text{ m}$$

$$M = xR_A - 200x(x/2)$$

$$M = 2.4(500) - 200(2.4)(2.4/2)$$

$$M = 624 \text{ N}\cdot\text{m}$$

$$f_b = \frac{Mc}{I} = \frac{624(1000)(50/2)}{\frac{50(50^3)}{12}}$$

$$f_b = 29.952 \text{ MPa}$$

Problem 515

Repeat Prob. 524 to find the maximum flexural stress at section b-b.

Solution 515

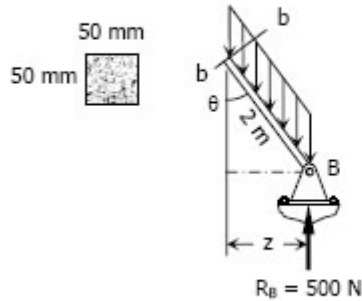

At section b-b:

$$\sin \theta = \frac{z}{2} = \frac{3}{5}$$

$$z = 1.5 \text{ m}$$

$$M = zR_B - 200z(z/2)$$

$$M = 1.5(500) - 200(1.5)(1.5/2)$$

$$M = 525 \text{ N}\cdot\text{m}$$

$$f_b = \frac{Mc}{I} = \frac{525(1000)(50/2)}{\frac{50(50)^3}{12}}$$

$$f_b = 25.2 \text{ MPa}$$

Problem 516

A timber beam AB, 6 in wide by 10 in deep and 10 ft long, is supported by a guy wire AC in the position shown in Fig. P-516. The beam carries a load, including its own weight, of 500 lb for each foot of its length. Compute the maximum flexural stress at the middle of the beam.

Figure P-516

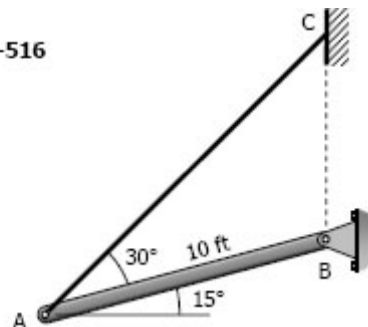

Solution 516

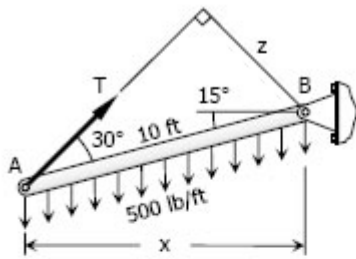

$$x = 10 \cos 15^\circ$$

$$x = 9.66 \text{ ft}$$

$$z = 10 \sin 30^\circ$$

$$z = 5 \text{ ft}$$

$$\Sigma M_B = 0$$

$$zT = 500(10)(x/2)$$

$$5T = 500(10)(9.66/2)$$

$$T = 4829.63 \text{ lb}$$

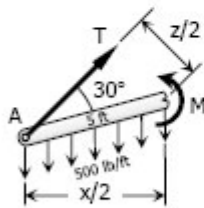

At midspan:

$$M = T(z/2) - 500(5)(x/4)$$

$$M = 4829.63(5/2) - 500(5)(9.66/4)$$

$$M = 6036.58 \text{ lb-ft}$$

$$f_b = \frac{Mc}{I} = \frac{M(h/2)}{\frac{bh^3}{12}}$$

$$f_b = \frac{6036.58(12)(10/2)}{\frac{6(10^3)}{12}}$$

$$f_b = 724.39 \text{ psi}$$

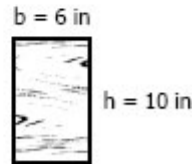

Problem 517

A rectangular steel bar, 15 mm wide by 30 mm high and 6 m long, is simply supported at its ends. If the density of steel is 7850 kg/m^3 , determine the maximum bending stress caused by the weight of the bar.

Solution 517

$$w = (7850 \text{ kg/m}^3)(0.015 \text{ m} \times 0.03 \text{ m})$$

$$= (3.5325 \text{ kg/m})(9.81 \text{ m/s}^2)$$

$$= 34.65 \text{ N/m}$$

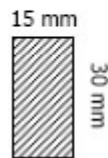
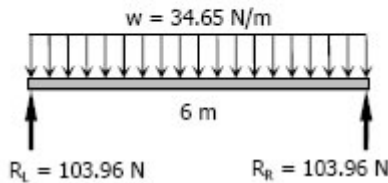

$$R_L = R_R = 6w/2$$

$$= 6(34.65)/2$$

$$= 103.96 \text{ N}$$

For simply supported beam subjected to uniformly distributed load, the maximum moment will occur at the midspan. At midspan:

$$M = 3(103.96) - 34.65(3)(3/2)$$

$$M = 155.955 \text{ N}\cdot\text{m}$$

$$(f_b)_{\max} = \frac{Mc}{I} = \frac{M(h/2)}{\frac{bh^3}{12}}$$

$$(f_b)_{\max} = \frac{155.955(1000)(30/2)}{\frac{15(30^3)}{12}}$$

$$(f_b)_{\max} = 69.31 \text{ MPa}$$

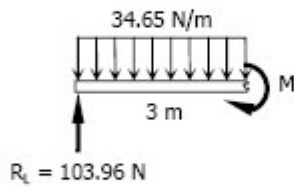

Problem 518

A cantilever beam 4 m long is composed of two C200 × 28 channels riveted back to back. What uniformly distributed load can be carried, in addition to the weight of the beam, without exceeding a flexural stress of 120 MPa if (a) the webs are vertical and (b) the webs are horizontal? Refer to Appendix B of text book for channel properties.

Solution 518

Relevant data from Appendix B, Table B-4 Properties of Channel Sections: SI Units, of text book.

Designation.....	C200 × 28
Area.....	3560 mm ²
Width.....	64 mm
S _{x-x}	180 × 10 ³ mm ³
I _{y-y}	0.825 × 10 ⁶ mm ⁴
x.....	14.4 mm

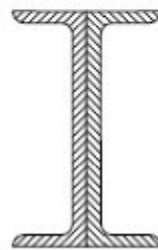
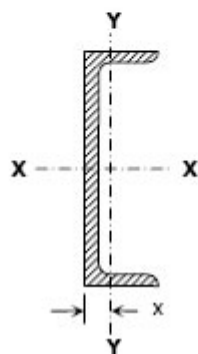

Webs are Vertical



Webs are horizontal

a. Webs are vertical

$$(f_b)_{\max} = \frac{M}{S}$$

$$120 = \frac{M}{2(180 \times 10^3)}$$

$$M = 43,200,000 \text{ N}\cdot\text{mm}$$

$$M = 43.2 \text{ kN}\cdot\text{m}$$

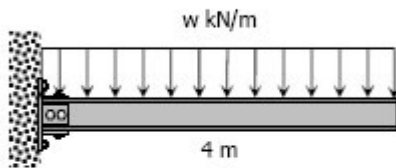

From the figure:

$$M = 4w(2)$$

$$M = 8w$$

$$43.2 = 8w$$

$$w = 5.4 \text{ kN/m}$$

$$w = 550.46 \text{ kg/m}$$

$w = \text{dead load, } DL + \text{live load, } LL$

$$550.46 = 2(28) + LL$$

$$LL = 494.46 \text{ kg/m}$$

b. Webs are horizontal

$$I_{\text{back}} = I_{Y-Y} + Ax^2$$

$$I_{\text{back}} = (0.825 \times 10^8) + 3560(14.4^2)$$

$$I_{\text{back}} = 1\,563\,201.6 \text{ mm}^4$$

$$I = 2I_{\text{back}} = 2(1\,563\,201.6)$$

$$I = 3\,126\,403.2 \text{ mm}^4$$

$$(f_b)_{\max} = \frac{Mc}{I}$$

$$120 = \frac{M(64)}{3\,126\,403.2}$$

$$M = 5\,862\,006 \text{ N}\cdot\text{mm}$$

$$M = 5.862 \text{ kN}\cdot\text{m}$$

From the figure:

$$M = 4w(2)$$

$$M = 8w$$

$$5.862 = 8w$$

$$w = 0.732\,75 \text{ kN/m}$$

$$w = 74.69 \text{ kg/m}$$

$w = \text{dead load, } DL + \text{live load, } LL$

$$74.69 = 2(28) + LL$$

$$LL = 18.69 \text{ kg/m}$$

Problem 519

A 30-ft beam, simply supported at 6 ft from either end carries a uniformly distributed load of intensity w_0 over its entire length. The beam is made by welding two S18 × 70 (see appendix B of text book) sections along their flanges to form the section shown in Fig. P-519. Calculate the maximum value of w_0 if the flexural stress is limited to 20 ksi. Be sure to include the weight of the beam.

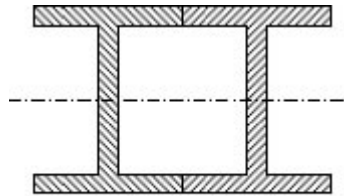
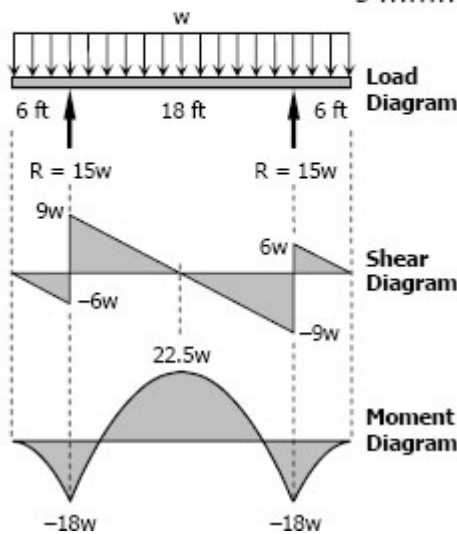

Figure P-519

Solution 519

Relevant data from Appendix B, Table B-8 Properties of I-Beam Sections (S-Shapes): US Customary Units, of text book.

Designation..... S18 × 70
 S 103 in³



$$(f_b)_{\max} = \frac{M}{S}$$

$$20 = \frac{M}{2(103)}$$

$$M = 4120 \text{ kip-in}$$

$$M = \frac{1030}{3} \text{ kip-ft}$$

From the moment diagram:

$$M = 22.5w$$

$$\frac{1030}{3} = 22.5w$$

$$w = 15.26 \text{ kip/ft}$$

$w =$ dead load, DL + live load, w_0

$$15.26(1000) = 2(70) + w_0$$

$$w_0 = 15\,120 \text{ lb/ft}$$

$$w_0 = 15.12 \text{ kip/ft}$$

Problem 520

A beam with an S310 × 74 section (see Appendix B of textbook) is used as a simply supported beam 6 m long. Find the maximum uniformly distributed load that can be applied over the entire length of the beam, in addition to the weight of the beam, if the flexural stress is not to exceed 120 MPa.

Solution 520

Relevant data from Appendix B, Table B-4 Properties of I-Beam Sections (S-Shapes): SI Units, of text book.

Designation..... S310 × 74
 S 833 × 10³ mm³

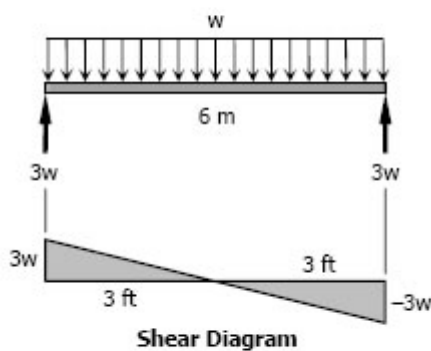

From the shear diagram:

$$M_{max} = \frac{1}{2} (3)(3w)$$

$$M_{max} = 4.5w \text{ N}\cdot\text{m}$$

$$(f_b)_{max} = \frac{M}{S}$$

$$120 = \frac{4.5w(1000)}{833 \times 10^3}$$

$$w = 22,213.33 \text{ N/m}$$

$$w = 2,264.36 \text{ kg/m}$$

$$w = DL + LL$$

$$2\,264.36 = 74 + LL$$

$$LL = 2,190.36 \text{ kg/m}$$

$$LL = 21.5 \text{ kN/m}$$

Problem 521

A beam made by bolting two C10 × 30 channels back to back, is simply supported at its ends. The beam supports a central concentrated load of 12 kips and a uniformly distributed load of 1200 lb/ft, including the weight of the beam. Compute the maximum length of the beam if the flexural stress is not to exceed 20 ksi.

Solution 521

Relevant data from Appendix B, Table B-9 Properties of Channel Sections: US Customary Units, of text book.

Designation..... C10 × 30
S 20.7 in³

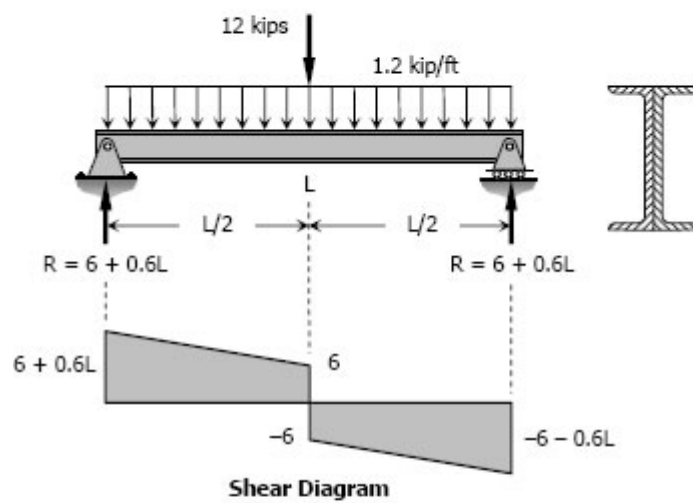

From the shear diagram:

$$M_{\max} = \frac{1}{2} [(6 + 0.6L) + 6](L/2)$$

$$M_{\max} = 3L + 0.15L^2$$

$$(f_b)_{\max} = \frac{M}{S}$$

$$20(1000) = \frac{(3L + 0.15L^2)(1000)(12)}{2(20.7)}$$

$$0.15L^2 + 3L - 69 = 0$$

$$L = 13.66 \text{ and } -33.66 \text{ (meaningless)}$$

$$\text{Use } L = 13.66 \text{ ft}$$

Problem 522

A box beam is composed of four planks, each 2 inches by 8 inches, securely spiked together to form the section shown in Fig. P-522. Show that $I_{NA} = 981.3 \text{ in}^4$. If $w_0 = 300 \text{ lb/ft}$, find P to cause a maximum flexural stress of 1400 psi.

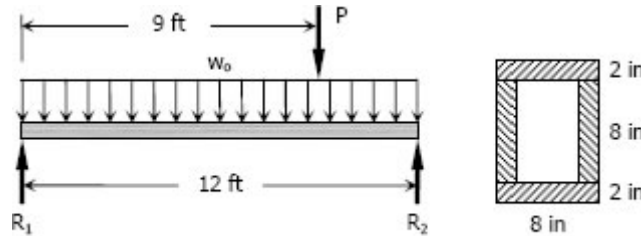
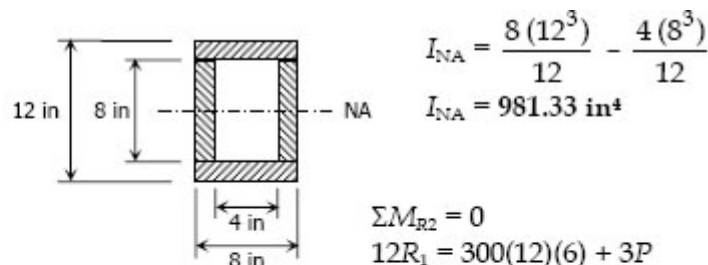

Figure P-522 and P-523

Solution 522



$$I_{NA} = \frac{8(12^3)}{12} - \frac{4(8^3)}{12}$$

$$I_{NA} = 981.33 \text{ in}^4$$

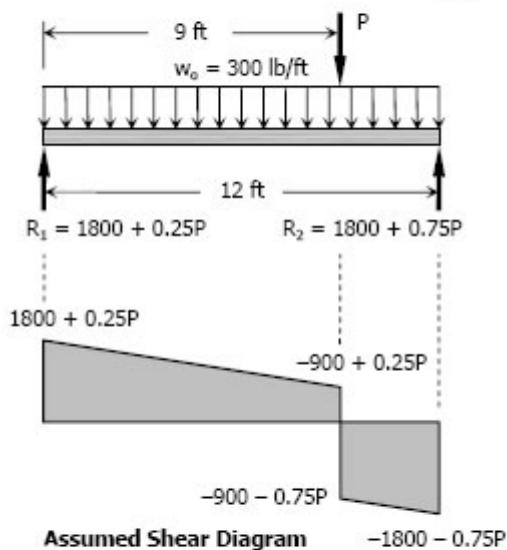

$$\Sigma M_{R2} = 0$$

$$12R_1 = 300(12)(6) + 3P$$

$$R_1 = 1800 + 0.25P$$

$$\Sigma M_{R1} = 0$$

$$12R_2 = 300(12)(6) + 9P$$

$$R_2 = 1800 + 0.75P$$

$$M = \frac{1}{2} [(1800 + 0.25P) + (-900 + 0.25P)](9)$$

$$M = 4050 + 2.25P \text{ lb-ft}$$

$$(f_b)_{\max} = \frac{Mc}{I}$$

$$1400 = \frac{(4050 + 2.25P)(6)(12)}{981.33}$$

$$P = 6680.63 \text{ lb}$$

Check if the shear at P is positive as assumed

$$-900 + 0.25P = -900 + 0.25(6680.63)$$

$$= 770.16 \text{ lb (ok!)}$$

Thus, $P = 6680.63 \text{ lb}$

Problem 523

Solve Prob. 522 if $w_0 = 600 \text{ lb/ft}$.

Solution 523

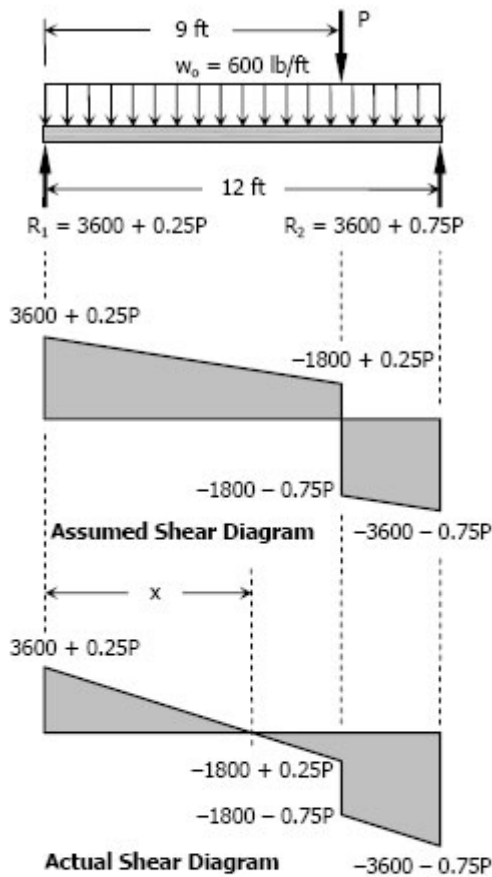

$$\begin{aligned}\Sigma M_{R2} &= 0 \\ 12R_1 &= 600(12)(6) + 3P \\ R_1 &= 3600 + 0.25P\end{aligned}$$

$$\begin{aligned}\Sigma M_{R1} &= 0 \\ 12R_2 &= 600(12)(6) + 9P \\ R_2 &= 3600 + 0.75P\end{aligned}$$

$$\begin{aligned}M &= \frac{1}{2} [(3600 + 0.25P) \\ &\quad + (-1800 + 0.25P)](9) \\ M &= 8100 + 2.25P \text{ lb-ft}\end{aligned}$$

$$\begin{aligned}(f_b)_{\max} &= \frac{Mc}{I} \\ 1400 &= \frac{(8100 + 2.25P)(6)(12)}{981.33}\end{aligned}$$

$$P = 4880.63 \text{ lb}$$

Check if the shear at P is positive as assumed

$$\begin{aligned}-1800 + 0.25P & \\ &= -1800 + 0.25(4880.63) \\ &= -579.84 \text{ lb (not ok!)}\end{aligned}$$

From the actual shear diagram:

$$\begin{aligned}(3600 + 0.25P) - 600x &= 0 \\ x &= \frac{3600 + 0.25P}{600}\end{aligned}$$

$$\begin{aligned}M_{\max} &= \frac{1}{2} x (3600 + 0.25P) \\ M_{\max} &= \frac{1}{2} \left(\frac{3600 + 0.25P}{600} \right) (3600 + 0.25P) \\ M_{\max} &= \frac{(3600 + 0.25P)^2}{1200}\end{aligned}$$

$$\begin{aligned}(f_b)_{\max} &= \frac{Mc}{I} \\ 1400 &= \frac{(3600 + 0.25P)^2}{1200} (6)(12)\end{aligned}$$

$$\begin{aligned}22\,897\,700 &= (3600 + 0.25P)^2 \\ P &= 4740.62 \text{ lb}\end{aligned}$$

Problem 524

A beam with an S380 × 74 section carries a total uniformly distributed load of 3W and a concentrated load W, as shown in Fig. P-524. Determine W if the flexural stress is limited to 120 MPa.

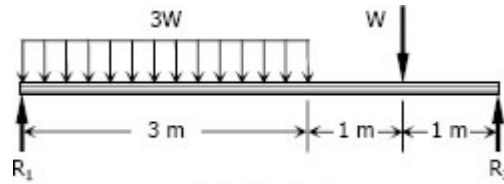
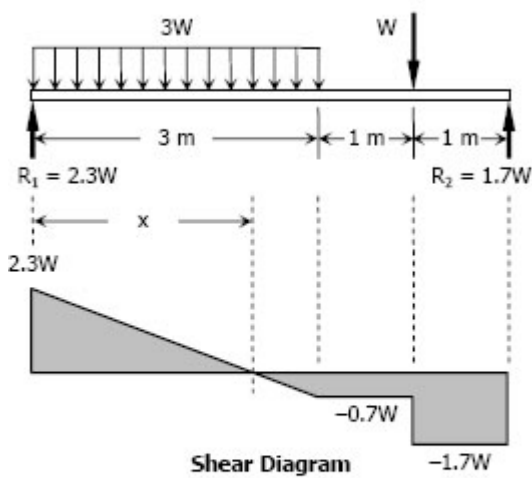

Figure P-524

Solution 524



$$\begin{aligned} \Sigma M_{R2} &= 0 \\ 5R_1 &= 3W(3.5) + W(1) \\ R_1 &= 2.3W \end{aligned}$$

$$\begin{aligned} \Sigma M_{R1} &= 0 \\ 5R_2 &= 3W(1.5) + W(4) \\ R_2 &= 1.7W \end{aligned}$$

$$\begin{aligned} 2.3W - Wx &= 0 \\ x &= 2.3 \text{ m} \end{aligned}$$

$$\begin{aligned} M_{\max} &= \frac{1}{2} x (2.3W) \\ M_{\max} &= \frac{1}{2} (2.3)(2.3W) \\ M_{\max} &= 2.645W \end{aligned}$$

From Appendix B, Table B-3 Properties of I-Beam Sections (S-Shapes): SI Units, of text book.

Designation..... S380 × 74
 S..... 1 060 × 10³ mm³

$$\begin{aligned} (f_b)_{\max} &= \frac{M}{S} \\ 120 &= \frac{2.645W(1000)}{1060 \times 10^3} \\ W &= 48\,090.74 \text{ N} \end{aligned}$$

Problem 525

A square timber beam used as a railroad tie is supported by a uniformly distributed load and carries two uniformly distributed loads each totaling 48 kN as shown in Fig. P-525. Determine the size of the section if the maximum stress is limited to 8 MPa.

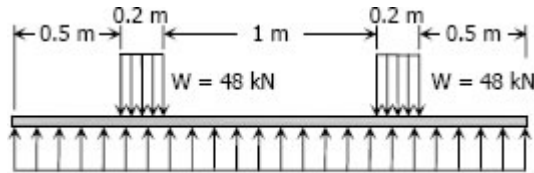
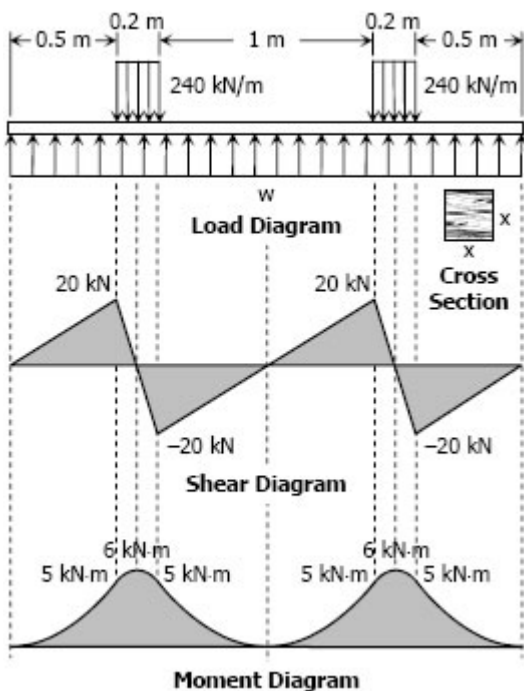

Figure P-524

Solution 525



$$\begin{aligned} \Sigma F_V &= 0 \\ 2.4w &= 240(0.2) + 240(0.2) \\ w &= 40 \text{ kN/m} \end{aligned}$$

$$(f_b)_{\max} = \frac{Mc}{I}$$

Where: $f_b = 8 \text{ MPa}$
 $M = 6 \text{ kN}\cdot\text{m}$

$$c = \frac{1}{2}x$$

$$\begin{aligned} I &= \frac{bh^3}{12} = \frac{x(x^3)}{12} \\ &= \frac{1}{12}x^4 \end{aligned}$$

$$8 = \frac{6(\frac{1}{2}x)(1000^2)}{\frac{1}{12}x^4}$$

$$x^3 = 4\,500\,000$$

$$x = 165.1 \text{ mm square}$$

Problem 526

A wood beam 6 in wide by 12 in deep is loaded as shown in Fig. P-526. If the maximum flexural stress is 1200 psi, find the maximum values of w_0 and P which can be applied simultaneously?

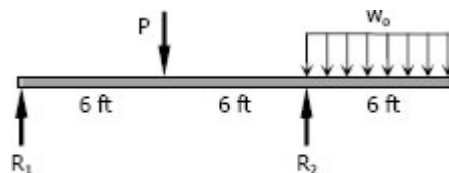
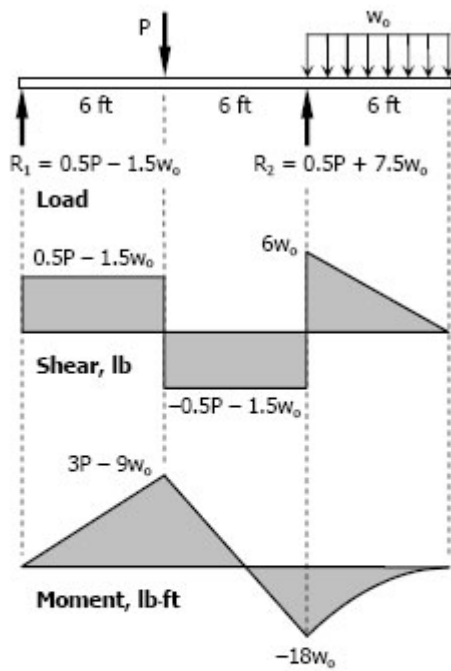

Figure P-526 and P-527

Solution 526



$$\begin{aligned} \Sigma M_{R2} &= 0 \\ 12R_1 + 3(6w_o) &= 6P \\ R_1 &= 0.5P - 1.5w_o \end{aligned}$$

$$\begin{aligned} \Sigma M_{R1} &= 0 \\ 12R_2 &= 6P + 15(6w_o) \\ R_2 &= 0.5P + 7.5w_o \end{aligned}$$

$$(f_b)_{\max} = \frac{Mc}{I}$$

Where: $f_b = 1200$ psi
 $c = \frac{1}{2}h = \frac{1}{2}(12) = 6$ in

$$\begin{aligned} I &= \frac{bh^3}{12} = \frac{6(12^3)}{12} \\ &= 864 \text{ in}^4 \end{aligned}$$

For moment at R_2 :

$$1200 = \frac{18w_o(6)(12)}{864}$$

$$w_o = 800 \text{ lb/ft}$$

For moment under P :

$$1200 = \frac{(3P - 9w_o)(6)(12)}{864}$$

$$14\,400 = 3P - 9w_o$$

$$14\,400 = 3P - 9(800)$$

$$P = 7200 \text{ lb}$$

Problem 527

In Prob. 526, if the load on the overhang is 600 lb/ft and the overhang is x ft long, find the maximum values of P and x that can be used simultaneously.

Solution 527

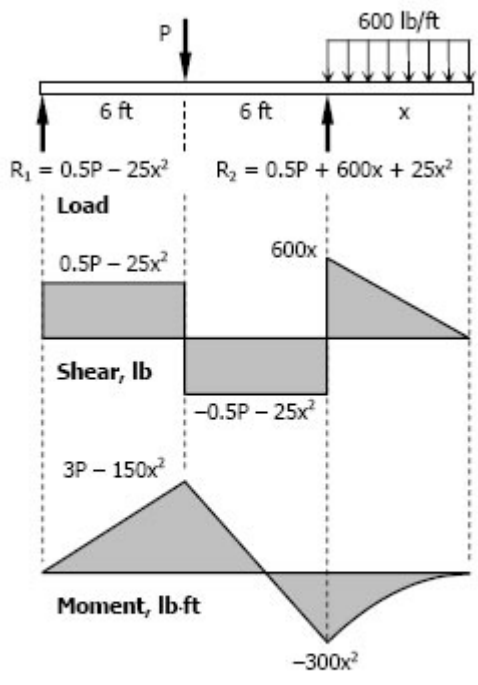

$$\begin{aligned} \Sigma M_{R_2} &= 0 \\ 12R_1 + 600x(x/2) &= 6P \\ R_1 &= 0.5P - 25x^2 \end{aligned}$$

$$\begin{aligned} 12R_2 &= 6P + 600x(12 + \frac{1}{2}x) \\ R_2 &= 0.5P + 600x + 25x^2 \end{aligned}$$

$$(f_b)_{\max} = \frac{Mc}{I}$$

Refer to Solution 526 for values of c and I .

For moment at R_2 :

$$1200 = \frac{(300x^2)(6)(12)}{864}$$

$$x^2 = 48$$

$$x = 6.93 \text{ ft}$$

For moment under P :

$$1200 = \frac{(3P - 150x^2)(6)(12)}{864}$$

$$14\,400 = 3P - 150x^2$$

$$14\,400 = 3P - 150(6.93^2)$$

$$P = 7\,201.245 \text{ lb}$$

Economic Sections

From the flexure formula $f_b = My / I$, it can be seen that the bending stress at the neutral axis, where $y = 0$, is zero and increases linearly outwards. This means that for a rectangular or circular section a large portion of the cross section near the middle section is understressed.

For steel beams or composite beams, instead of adopting the rectangular shape, the area may be arranged so as to give more area on the outer fiber and maintaining the same overall depth, and saving a lot of weight.

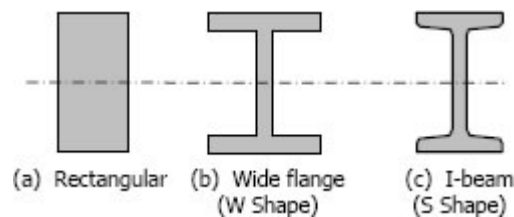

When using a wide flange or I-beam section for long beams, the compression flanges tend to buckle horizontally sidewise. This buckling is a column effect, which may be prevented by providing lateral support such as a floor system so that the full allowable stresses may be used, otherwise the stress should be reduced. The reduction of stresses for these beams will be discussed in steel design. In selecting a structural section to be used as a beam, the resisting moment must be equal or greater than the applied bending moment. Note: $(f_b)_{\max} = M/S$.

$$S_{\text{required}} \geq S_{\text{live-load}} \text{ OR } S_{\text{required}} \geq \frac{M_{\text{live-load}}}{(f_b)_{\max}}$$

The equation above indicates that the required section modulus of the beam must be equal or greater than the ratio of bending moment to the maximum allowable stress. A check that includes the weight of the selected beam is necessary to complete the calculation. In checking, the beams resisting moment must be equal or greater than the sum of the live-load moment caused by the applied loads and the dead-load moment caused by dead weight of the beam.

$$M_{\text{resisting}} \geq M_{\text{live-load}} + M_{\text{dead-load}}$$

Dividing both sides of the above equation by $(f_b)_{\max}$, we obtain the checking equation

$$S_{\text{resisting}} \geq S_{\text{live-load}} + S_{\text{dead-load}}$$

Assume that the beams in the following problems are properly braced against lateral deflection. Be sure to include the weight of the beam itself.

Solved Problems in Economic Sections

Problem 529

A 10-m beam simply supported at the ends carries a uniformly distributed load of 16 kN/m over its entire length. What is the lightest W shape beam that will not exceed a flexural stress of 120 MPa? What is the actual maximum stress in the beam selected?

Solution 529

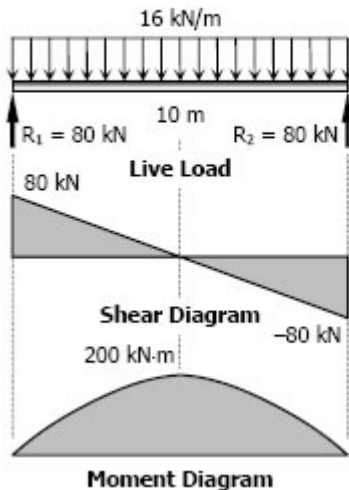

$$S_{\text{required}} \geq \frac{M_{\text{live-load}}}{(f_b)_{\text{max}}} \geq \frac{200(1000^2)}{120}$$

$$S_{\text{required}} \geq 1,666,666.67 \text{ mm}^3$$

$$S_{\text{required}} \geq 1\,666.67 \times 10^3 \text{ mm}^3$$

Starting at the bottom of Appendix B, Table B-2 Properties of Wide-Flange Sections (W Shapes): SI Units, of text book, the following are the first to exceed the S above:

Designation	Section Modulus
W250 × 149	$1\,840 \times 10^3 \text{ mm}^3$
W310 × 118	$1\,750 \times 10^3 \text{ mm}^3$
W360 × 101	$1\,690 \times 10^3 \text{ mm}^3$
W410 × 100	$1\,920 \times 10^3 \text{ mm}^3$

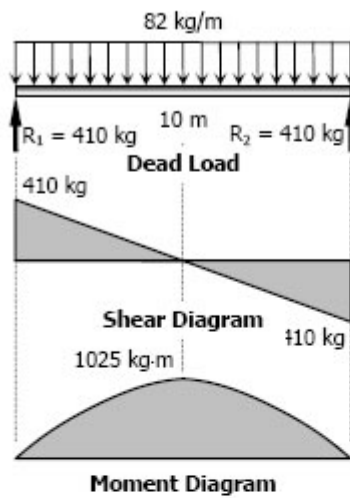

W460 × 89	1 770 × 10 ³ mm ³
W530 × 85	1 810 × 10 ³ mm ³
W610 × 82	1 870 × 10 ³ mm ³
W690 × 125	3 500 × 10 ³ mm ³

Use the lightest section W610 × 82

Checking:

$$S_{\text{resisting}} \geq S_{\text{live-load}} + S_{\text{dead-load}}$$

$$S_{\text{live-load}} = 1\,666.67 \times 10^3 \text{ mm}^3$$

$$S_{\text{dead-load}} = \frac{1025(9.81)(1000)}{120}$$

$$= 83.79 \times 10^3 \text{ mm}^3$$

$$S_{\text{live-load}} + S_{\text{dead-load}}$$

$$= (1\,666.67 \times 10^3) + (83.79 \times 10^3)$$

$$= 1\,750.46 \times 10^3 \text{ mm}^3$$

The resisting S of W610 × 82 is $1\,870 \times 10^3 \text{ mm}^3$, the S due to live-load and dead-load is only $1\,750.46 \times 10^3 \text{ mm}^3$, therefore, the chosen section is sufficient to resist the combined dead-load and live-load.

Actual bending moment due to dead and live loads:

$$M = M_{\text{live-load}} + M_{\text{dead-load}}$$

$$M = 200 + 1025(9.81/1000)$$

$$M = 210.06 \text{ kN}\cdot\text{m}$$

Actual stress:

$$(f_b)_{\text{max}} = \frac{M}{S}$$

$$= \frac{210.06(1000^2)}{1870 \times 10^3}$$

$$= 112.33 \text{ MPa}$$

Problem 530

Repeat Prob. 529 if the distributed load is 12 kN/m and the length of the beam is 8 m.

Solution 530

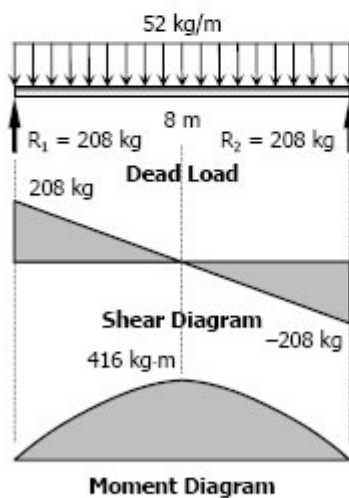
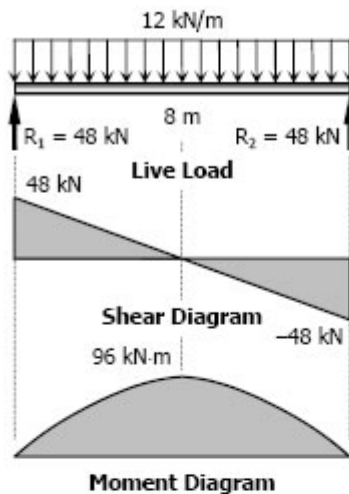

$$S_{\text{required}} \geq \frac{M_{\text{live-load}}}{(f_b)_{\text{max}}} \geq \frac{96(1000^2)}{120}$$

$$S_{\text{required}} \geq 800 \times 10^3 \text{ mm}^3$$

From Appendix B, Table B-2 Properties of Wide-Flange Sections (W Shapes): SI Units, of text book:

Designation	Section Modulus
W200 × 86	$853 \times 10^3 \text{ mm}^3$
W250 × 67	$806 \times 10^3 \text{ mm}^3$
W310 × 60	$849 \times 10^3 \text{ mm}^3$
W360 × 57	$897 \times 10^3 \text{ mm}^3$
W410 × 54	$924 \times 10^3 \text{ mm}^3$
W460 × 52	$943 \times 10^3 \text{ mm}^3$

Use the lightest section W460 × 60

Checking:

$$S_{\text{resisting}} \geq S_{\text{live-load}} + S_{\text{dead-load}}$$

$$S_{\text{live-load}} = 800 \times 10^3 \text{ mm}^3$$

$$S_{\text{dead-load}} = \frac{416(9.81)(1000)}{120}$$

$$= 34 \times 10^3 \text{ mm}^3$$

$$S_{\text{live-load}} + S_{\text{dead-load}}$$

$$= (800 \times 10^3) + (34 \times 10^3)$$

$$= 834 \times 10^3 \text{ mm}^3$$

$$(943 \times 10^3 \text{ mm}^3) > (834 \times 10^3 \text{ mm}^3) \text{ (ok!)}$$

Actual bending moment:

$$M = M_{\text{live-load}} + M_{\text{dead-load}}$$

$$M = 96 + 416(9.81/1000) = 100.08 \text{ kN-m}$$

Actual stress:

$$(f_b)_{\text{max}} = \frac{M}{S} = \frac{100.08(1000^2)}{943 \times 10^3}$$

$$(f_b)_{\text{max}} = 106.13 \text{ MPa}$$

Problem 531

A 15-ft beam simply supported at the ends carries a concentrated load of 9000 lb at midspan. Select the lightest S section that can be employed using an allowable stress of 18 ksi. What is the actual maximum stress in the beam selected?

Solution 531

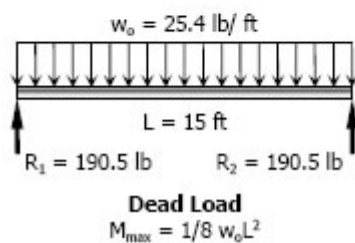
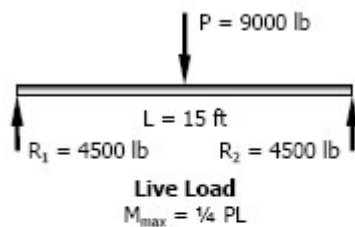

$$S_{\text{required}} \geq \frac{M_{\text{live-load}}}{(f_b)_{\max}} \geq \frac{\frac{1}{4}(9000)(15)(12)}{18000}$$

$$S_{\text{required}} \geq 22.5 \text{ in}^3$$

From Appendix B, Table B-8 Properties of I-Beam Sections (S Shapes): US Customary Units, of text book:

Use S10 × 25.4 with $S = 24.7 \text{ in}^3$

Checking:

$$S_{\text{resisting}} \geq S_{\text{live-load}} + S_{\text{dead-load}}$$

$$S_{\text{live-load}} = 22.5 \text{ in}^3$$

$$S_{\text{dead-load}} = \frac{\frac{1}{8}(25.4)(15^2)(12)}{18000}$$

$$= 0.48 \text{ in}^3$$

$$S_{\text{live-load}} + S_{\text{dead-load}} = 22.5 + 0.48$$

$$= 22.98 \text{ in}^3$$

$$(S_{\text{resisting}} = 24.7 \text{ in}^3) > 22.98 \text{ in}^3 \text{ (ok!)}$$

Actual bending moment:

$$M = M_{\text{live-load}} + M_{\text{dead-load}}$$

$$M = \frac{1}{4} PL + \frac{1}{8} w_0 L^2$$

$$M = \frac{1}{4} (9000)(15) + \frac{1}{8} (25.4)(15^2)$$

$$M = 34,464.38 \text{ lb-ft}$$

Actual stress:

$$(f_b)_{\max} = \frac{M}{S} = \frac{34,464.38(12)}{24.7}$$

$$(f_b)_{\max} = 16,743.83 \text{ psi}$$

$$(f_b)_{\max} = 16.74 \text{ ksi}$$

Problem 532

A beam simply supported at the ends of a 25-ft span carries a uniformly distributed load of 1000 lb/ft over its entire length. Select the lightest S section that can be used if the allowable stress is 20 ksi. What is the actual maximum stress in the beam selected?

Solution 532

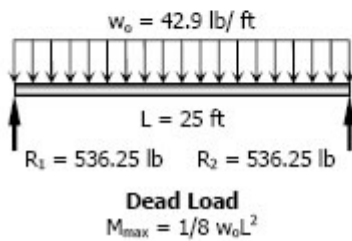
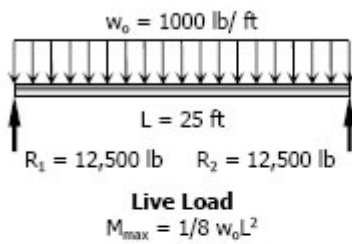

$$S_{\text{required}} \geq \frac{M}{(f_b)_{\max}} \geq \frac{\frac{1}{8}(1000)(25^2)(12)}{20000}$$

$$S_{\text{required}} \geq 46.875 \text{ in}^3$$

From Appendix B, Table B-8 Properties of I-Beam Sections (S Shapes): US Customary Units, of text book:

Use S15 x 42.9 with $S = 59.6 \text{ in}^3$

Checking:

$$S_{\text{resisting}} \geq S_{\text{live-load}} + S_{\text{dead-load}}$$

$$S_{\text{live-load}} = 46.875 \text{ in}^3$$

$$S_{\text{dead-load}} = \frac{\frac{1}{8}(42.9)(25^2)(12)}{20000}$$

$$= 2.011 \text{ in}^3$$

$$S_{\text{live-load}} + S_{\text{dead-load}} = 46.875 + 2.011 \\ = 48.886 \text{ in}^3$$

$$(S_{\text{resisting}} = 59.6 \text{ in}^3) > 48.886 \text{ in}^3 \text{ (ok!)}$$

Actual bending moment:

$$M = M_{\text{live-load}} + M_{\text{dead-load}}$$

$$M = \left(\frac{1}{8} w_0 L^2\right)_{\text{live-load}} + \left(\frac{1}{8} w_0 L^2\right)_{\text{dead-load}}$$

$$M = \frac{1}{8} (1000)(25^2) + \frac{1}{8} (42.9)(25^2)$$

$$M = 81,476.56 \text{ lb-ft}$$

Actual stress:

$$(f_b)_{\max} = \frac{M}{S}$$

$$(f_b)_{\max} = \frac{81,476.56(12)}{59.6}$$

$$(f_b)_{\max} = 16,404.68 \text{ psi}$$

$$(f_b)_{\max} = 16.4 \text{ ksi}$$

Problem 533

A beam simply supported on a 36-ft span carries a uniformly distributed load of 2000 lb/ft over the middle 18 ft. Using an allowable stress of 20 ksi, determine the lightest suitable W shape beam. What is the actual maximum stress in the selected beam?

Solution 533

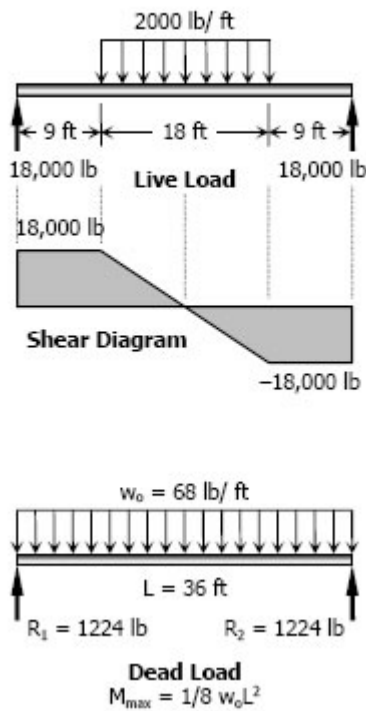

$$M_{\text{live-load}} = 18,000(9) + \frac{1}{2}(9)(18,000)$$

$$M_{\text{live-load}} = 243,000 \text{ lb-ft}$$

$$S_{\text{required}} \geq \frac{M_{\text{live-load}}}{(f_b)_{\text{max}}} \geq \frac{243,000(12)}{20,000}$$

$$S_{\text{required}} \geq 145.8 \text{ in}^3$$

From Appendix B, Table B-7 Properties of Wide-Flange Sections (W Shapes): US Customary Units, of text book:

Designation	Section Modulus
W12 × 120	163 in ³
W14 × 99	157 in ³
W16 × 89	155 in ³
W18 × 76	146 in ³
W21 × 73	151 in ³
W24 × 68	154 in ³

Use W24 × 68 with $S = 154 \text{ in}^3$

Checking:

$$S_{\text{resisting}} \geq S_{\text{live-load}} + S_{\text{dead-load}}$$

$$S_{\text{live-load}} = 145.8 \text{ in}^3$$

$$S_{\text{dead-load}} = \frac{\frac{1}{8}(68)(36^2)(12)}{20,000}$$

$$= 6.61 \text{ in}^3$$

$$S_{\text{live-load}} + S_{\text{dead-load}} = 145.8 + 6.61 = 152.41 \text{ in}^3$$

$$(S_{\text{resisting}} = 154 \text{ in}^3) > 152.41 \text{ in}^3 \text{ (ok!)}$$

Actual bending moment:

$$M = M_{\text{live-load}} + M_{\text{dead-load}}$$

$$M = 243,000 + \frac{1}{8}(68)(36^2)$$

$$M = 254,016 \text{ lb-ft}$$

Actual stress:

$$(f_b)_{\text{max}} = \frac{M}{S} = \frac{254,016(12)}{154}$$

$$(f_b)_{\text{max}} = 19,793.45 \text{ psi}$$

$$(f_b)_{\text{max}} = 19.79 \text{ ksi}$$

Problem 534

Repeat Prob. 533 if the uniformly distributed load is changed to 5000 lb/ft.

Solution 534

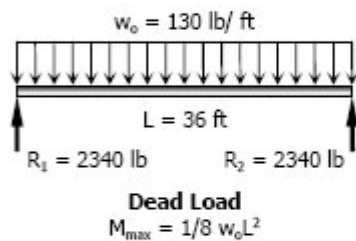
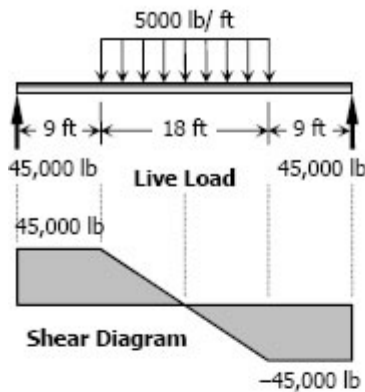

$$M_{\text{live-load}} = 45,000(9) + \frac{1}{2}(9)(45,000)$$

$$M_{\text{live-load}} = 607,500 \text{ lb}\cdot\text{ft}$$

$$S_{\text{required}} \geq \frac{M_{\text{live-load}}}{(f_b)_{\max}} \geq \frac{607,500(12)}{20,000}$$

$$S_{\text{required}} \geq 364.5 \text{ in}^3$$

From Appendix B, Table B-7 Properties of Wide-Flange Sections (W Shapes): US Customary Units, of text book:

Designation	Section Modulus
W12 × 279	393 in ³
W14 × 233	375 in ³
W24 × 146	371 in ³
W27 × 146	411 in ³
W30 × 132	380 in ³
W33 × 130	406 in ³

Use W33 × 130 with $S = 406 \text{ in}^3$

Checking:

$$S_{\text{resisting}} \geq S_{\text{live-load}} + S_{\text{dead-load}}$$

$$S_{\text{live-load}} = 364.5 \text{ in}^3$$

$$S_{\text{dead-load}} = \frac{\frac{1}{8}(130)(36^2)(12)}{20,000}$$

$$= 12.636 \text{ in}^3$$

$$S_{\text{live-load}} + S_{\text{dead-load}} = 364.5 + 12.636$$

$$= 377.136 \text{ in}^3$$

$$(S_{\text{resisting}} = 406 \text{ in}^3) > 377.136 \text{ in}^3 \text{ (ok!)}$$

Actual bending moment:

$$M = M_{\text{live-load}} + M_{\text{dead-load}}$$

$$M = 607,500 + \frac{1}{8}(130)(36^2)$$

$$M = 628,560 \text{ lb}\cdot\text{ft}$$

Actual stress:

$$(f_b)_{\max} = \frac{M}{S} = \frac{628,560(12)}{406}$$

$$(f_b)_{\max} = 18,578.13 \text{ psi}$$

$$(f_b)_{\max} = 18.58 \text{ ksi}$$

Problem 535

A simply supported beam 24 ft long carries a uniformly distributed load of 2000 lb/ft over its entire length and a concentrated load of 12 kips at 8 ft from left end. If the allowable stress is 18 ksi, select the lightest suitable W shape. What is the actual maximum stress in the selected beam?

Solution 535

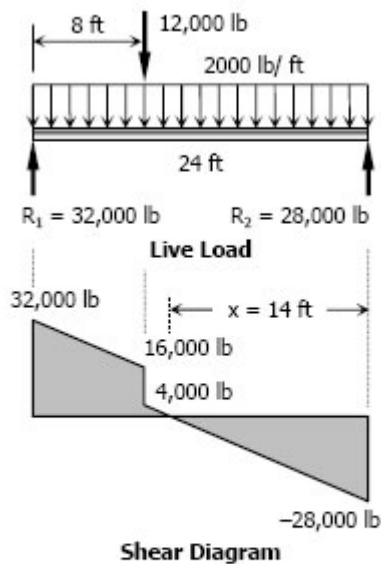

$$\Sigma M_{R2} = 0$$

$$24R_1 = 16(12\,000) + 2000(24)(12)$$

$$R_1 = 32,000 \text{ lb}$$

$$\Sigma M_{R1} = 0$$

$$24R_2 = 8(12\,000) + 2000(24)(12)$$

$$R_2 = 28,000 \text{ lb}$$

$$\frac{x}{28000} = \frac{16 - x}{4000}$$

$$4000x = 28\,000(16 - x)$$

$$32\,000x = 448\,000$$

$$x = 14 \text{ ft}$$

$$M_{\text{live-load}} = \frac{1}{2}x(28\,000) = \frac{1}{2}(14)(28\,000)$$

$$M_{\text{live-load}} = 196,000 \text{ lb}\cdot\text{ft}$$

$$S_{\text{required}} \geq \frac{M_{\text{live-load}}}{(f_b)_{\text{max}}} \geq \frac{196\,000(12)}{18\,000}$$

$$S_{\text{required}} \geq 130.67 \text{ in}^3$$

From Appendix B, Table B-7 Properties of Wide-Flange Sections (W Shapes): US Customary Units, of text book:

Designation	Section Modulus
W12 × 96	131 in ³
W14 × 90	143 in ³
W16 × 77	134 in ³
W18 × 76	146 in ³
W21 × 68	140 in ³
W24 × 62	131 in ³

Try W24 × 62 with $S = 131 \text{ in}^3$

Checking:

$$S_{\text{resisting}} \geq S_{\text{live-load}} + S_{\text{dead-load}}$$

$$S_{\text{live-load}} = 130.67 \text{ in}^3$$

$$\frac{y}{2} = \frac{744}{12}; y = 124 \text{ lb}$$

At critical section:

$$M_{\text{dead-load}} = \frac{1}{2}(744 + 124)(10) = 4340 \text{ lb}\cdot\text{ft}$$

$$S_{\text{dead-load}} = \frac{4340(12)}{18000} = 2.89 \text{ in}^3$$

$$S_{\text{live-load}} + S_{\text{dead-load}} = 130.67 + 2.89 = 133.56 \text{ in}^3$$

($S_{\text{resisting}} = 131 \text{ in}^3 < 133.56 \text{ in}^3$ (not ok!))

Try W21 × 68 with $S = 140 \text{ in}^3$

Checking:

$$S_{\text{resisting}} \geq S_{\text{live-load}} + S_{\text{dead-load}}$$

$$S_{\text{live-load}} = 130.67 \text{ in}^3$$

$$\frac{y}{2} = \frac{816}{12}; y = 136 \text{ lb}$$

At critical section:

$$M_{\text{dead-load}} = \frac{1}{2}(816 + 136)(10) = 4760 \text{ lb}\cdot\text{ft}$$

$$S_{\text{dead-load}} = \frac{4760(12)}{18000} = 3.17 \text{ in}^3$$

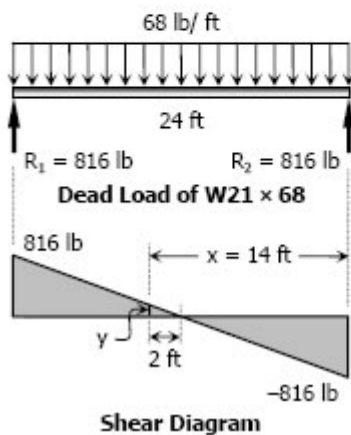
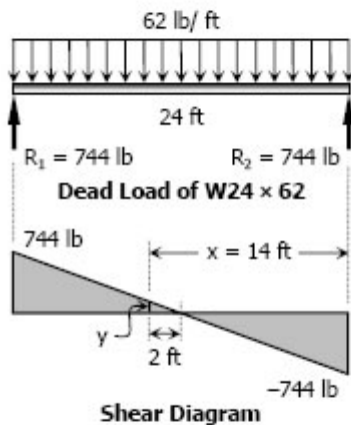

$$S_{\text{live-load}} + S_{\text{dead-load}} = 130.67 + 3.17$$

$$= 133.84 \text{ in}^3$$

$$(S_{\text{resisting}} = 140 \text{ in}^3) > 133.84 \text{ in}^3 \text{ (ok!)}$$

Use W21 × 68

Actual bending moment:

$$M = M_{\text{live-load}} + M_{\text{dead-load}} = 196,000 + 4,760$$

$$M = 200,760 \text{ lb-ft}$$

Actual stress:

$$(f_b)_{\text{max}} = \frac{M}{S} = \frac{200,760(12)}{140}$$

$$(f_b)_{\text{max}} = 17,208 \text{ psi}$$

$$(f_b)_{\text{max}} = 17.208 \text{ ksi}$$

Problem 536

A simply supported beam 10 m long carries a uniformly distributed load of 20 kN/m over its entire length and a concentrated load of 40 kN at midspan. If the allowable stress is 120 MPa, determine the lightest W shape beam that can be used.

Solution 536

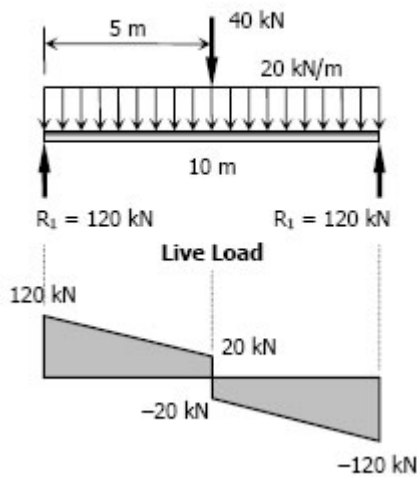

$$M_{\text{live-load}} = \frac{1}{2} (120 + 20)(5)$$

$$= 350 \text{ kN-m}$$

$$S_{\text{required}} \geq \frac{M_{\text{live-load}}}{(f_b)_{\text{max}}} \geq \frac{350(1000^2)}{120}$$

$$\geq 2,916.67 \times 10^3 \text{ mm}^3$$

From Appendix B, Table B-2 Properties of Wide-Flange Sections (W Shapes): SI Units, of text book:

Designation	Section Modulus
W310 × 202	3,050 × 10 ³ mm ³
W360 × 179	3,120 × 10 ³ mm ³
W460 × 144	3,080 × 10 ³ mm ³
W530 × 138	3,140 × 10 ³ mm ³
W610 × 125	3,220 × 10 ³ mm ³
W690 × 125	3,500 × 10 ³ mm ³

W610 × 125 has a theoretical mass of 125.1 kg/m while W690 × 125 has a theoretical mass of 125.6 kg/m. Thus, use W610 × 125 with $S = 3,220 \times 10^3 \text{ mm}^3$.

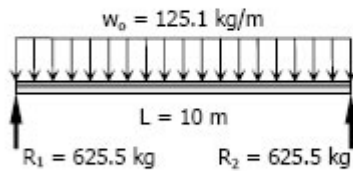

Dead Load
 $M_{\max} = 1/8 w_0 L^2$

Checking:

$$S_{\text{resisting}} \geq S_{\text{live-load}} + S_{\text{dead-load}}$$

$$S_{\text{live-load}} = 2,916.67 \times 10^3 \text{ mm}^3$$

$$S_{\text{dead-load}} = \frac{\frac{1}{8}(125.1)(9.81)(10^2)(1000)}{120}$$

$$= 127.84 \times 10^3 \text{ mm}^3$$

$$S_{\text{live-load}} + S_{\text{dead-load}}$$

$$= (2,916.67 \times 10^3) + (127.84 \times 10^3)$$

$$= 3,044.51 \times 10^3 \text{ mm}^3$$

$$(S_{\text{resisting}} = 3,220 \times 10^3 \text{ mm}^3) > 3,044.4 \times 10^3 \text{ mm}^3 \text{ (ok!)}$$

Floor Framing

In floor framing, the subfloor is supported by light beams called floor joists or simply joists which in turn supported by heavier beams called girders then girders pass the load to columns. Typically, joist act as simply supported beam carrying a uniform load of magnitude p over an area of sL ,

where

p = floor load per unit area

L = length (or span) of joist

s = center to center spacing of joists and

$w_o = sp$ = intensity of distributed load in joist.

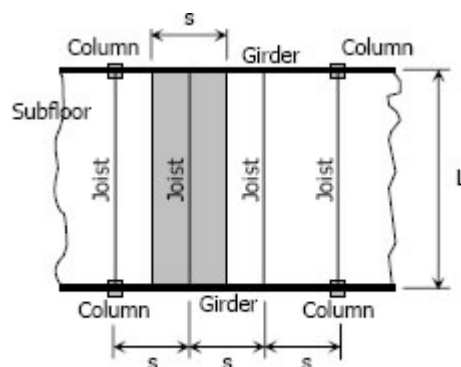

Typical Floor Framing Plan

Solved Problems in Floor Framing

Problem 538

Floor joists 50 mm wide by 200 mm high, simply supported on a 4-m span, carry a floor loaded at 5 kN/m². Compute the center-line spacing between joists to develop a bending stress of 8 MPa. What safe floor load could be carried on a center-line spacing of 0.40 m?

Solution 538

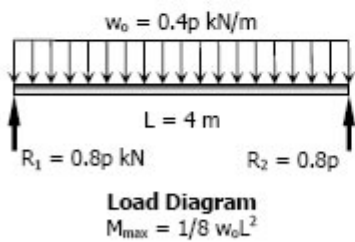
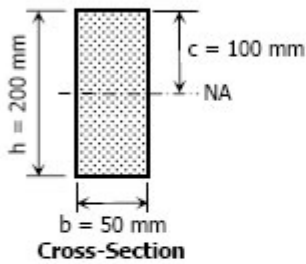
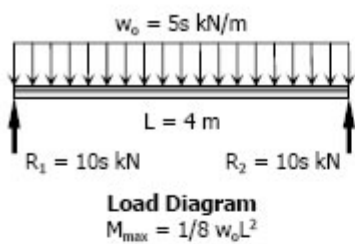

Part 1:

$$(f_b)_{\max} = \frac{Mc}{I}$$

where: $(f_b)_{\max} = 8 \text{ MPa}$

$$M = \frac{1}{8} (5s)(4^2)$$

$$= 10s \text{ kN}\cdot\text{m}$$

$$c = h/2$$

$$= 200/2$$

$$= 100 \text{ mm}$$

$$I = \frac{bh^3}{12}$$

$$= \frac{50(200^3)}{12}$$

$$= 33.33 \times 10^6 \text{ mm}^4$$

$$8 = \frac{10s(100)(1000^2)}{33.33 \times 10^6}$$

$$s = 0.267 \text{ m}$$

Part 2:

$$(f_b)_{\max} = \frac{Mc}{I}$$

where: $M = \frac{1}{8} w_o L^2$

$$= \frac{1}{8} (0.4p)(4^2)$$

$$= 0.8p$$

$$8 = \frac{0.8p(100)(1000^2)}{33.33 \times 10^6}$$

$$p = 3.33 \text{ kN/m}^2$$

Problem 539

Timbers 12 inches by 12 inches, spaced 3 feet apart on centers, are driven into the ground and act as cantilever beams to back-up the sheet piling of a coffer dam. What is the maximum safe height of water behind the dam if water weighs = 62.5 lb/ft³ and $(f_b)_{\max} = 1200$ psi?

Solution 539

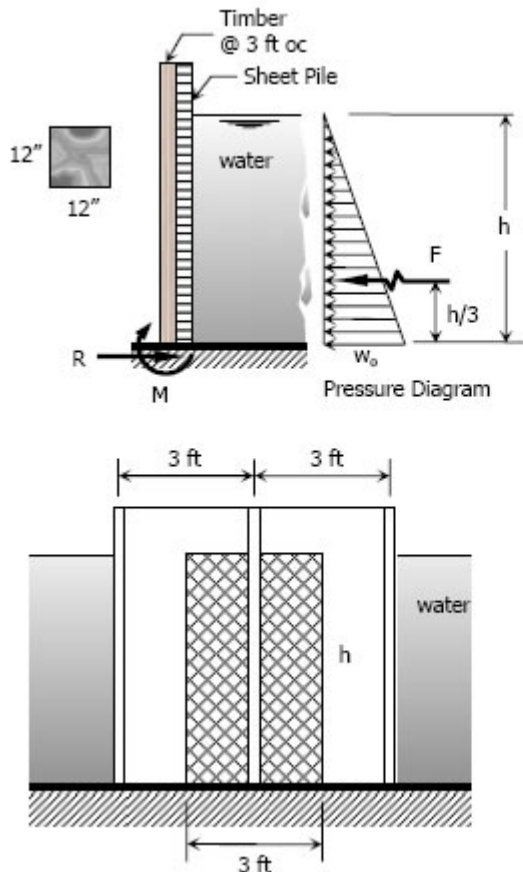

$$w_o = 62.5h \text{ lb/ft}^2$$

$$F = \frac{1}{2} w_o h (3)$$

$$F = \frac{1}{2} (62.5h)h$$

$$F = 93.75h^2 \text{ lb}$$

$$M = \left(\frac{1}{3} h\right)F$$

$$M = \frac{1}{3} h (93.75h^2)$$

$$M = 31.25h^3 \text{ lb}\cdot\text{ft}$$

$$(f_b)_{\max} = \frac{Mc}{I}$$

$$1200 = \frac{31.25h^3(12)(12/2)}{\frac{12(12^3)}{12}}$$

$$h = 9.73 \text{ ft}$$

Problem 540

Timbers 8 inches wide by 12 inches deep and 15 feet long, supported at top and bottom, back up a dam restraining water 9 feet deep. Water weighs 62.5 lb/ft³. (a) Compute the center-line spacing of the timbers to cause $f_b = 1000$ psi. (b) Will this spacing be safe if the maximum f_b , $(f_b)_{\max} = 1600$ psi, and the water reaches its maximum depth of 15 ft?

Solution 540

Part (a)

$$w_o = 62.5(9s)$$

$$w_o = 562.5s \text{ lb/ft}$$

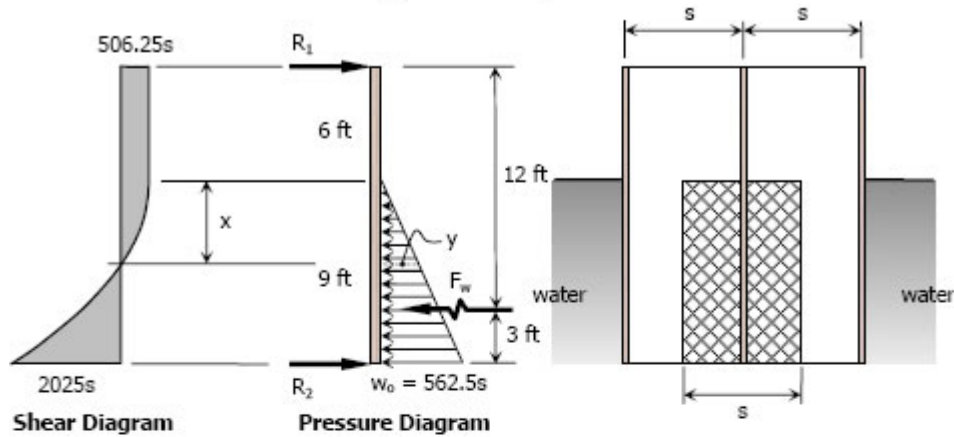

$$F_w = \frac{1}{2} w_o(9)$$

$$F_w = \frac{1}{2} (562.5s)(9)$$

$$F_w = 2531.25s \text{ lb}$$

$$\Sigma M_{R1} = 0$$

$$15R_2 = 12F_w$$

$$15R_2 = 12(2531.25s)$$

$$R_2 = 2025s$$

$$\Sigma M_{R2} = 0$$

$$15R_1 = 3F_w$$

$$15R_1 = 3(2531.25s)$$

$$R_1 = 506.25s$$

Location of Maximum Moment

$$\frac{y}{x} = \frac{562.5s}{9}$$

$$y = 62.5s$$

$$506.25s - \frac{1}{2}xy = 0$$

$$506.25s - \frac{1}{2}x(62.5sx) = 0$$

$$x^2 = 16.2$$

$$x = 4.02 \text{ ft}$$

Maximum Moment

$$M = (506.25s)(6) + \frac{2}{3}(x)(506.25s)$$

$$M = 3037.5s + 337.5(4.02s)$$

$$M = 4394.25s$$

Required Spacing

$$(f_b)_{\max} = \frac{Mc}{I}$$

$$1000 = \frac{4394.25s(12)(12/2)}{\frac{8(12^3)}{12}}$$

$$s = 3.64 \text{ ft}$$

Part (b)

$$w_o = 62.5(15)(3.64)$$

$$w_o = 3412.5 \text{ lb/ft}$$

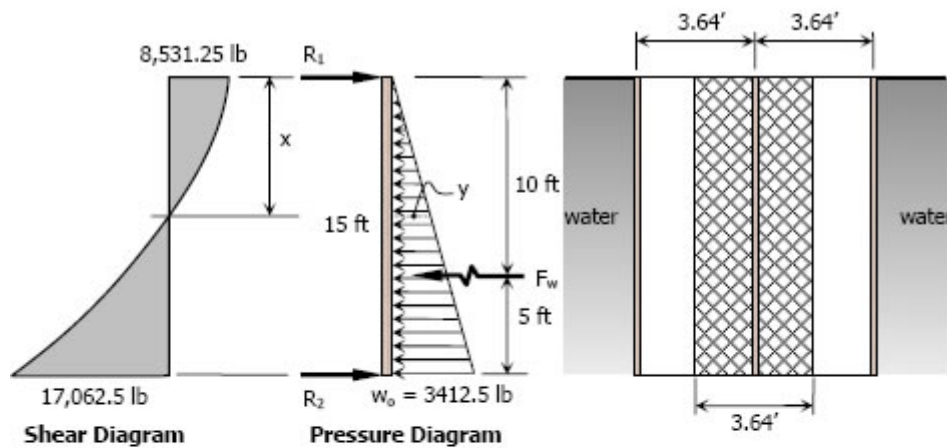

$$F_w = \frac{1}{2} w_o(15)$$

$$F_w = \frac{1}{2} (3412.5)(15)$$

$$F_w = 25,593.75 \text{ lb}$$

$$\Sigma M_{R1} = 0$$

$$15R_2 = 10F_w$$

$$15R_2 = 10(25,593.75)$$

$$R_2 = 17,062.5 \text{ lb}$$

$$\begin{aligned}\Sigma M_{R2} &= 0 \\ 15R_1 &= 5F_w \\ 15R_1 &= 5(25\,593.75) \\ R_1 &= 8,531.25 \text{ lb}\end{aligned}$$

Location of Maximum Moment (Shear = 0)

$$\begin{aligned}\frac{y}{x} &= \frac{3412.5}{15} \\ y &= 227.5x\end{aligned}$$

$$\begin{aligned}8531.25 - \frac{1}{2}xy &= 0 \\ 8531.25 - \frac{1}{2}x(227.5x) &= 0 \\ x^2 &= 75 \\ x &= 8.66 \text{ ft}\end{aligned}$$

Maximum Moment

$$\begin{aligned}M &= \frac{2}{3}x(8531.25) \\ M &= \frac{2}{3}(8.66)(8531.25) \\ M &= 49,255.19 \text{ lb-ft}\end{aligned}$$

Actual Stress

$$\begin{aligned}f_b &= \frac{Mc}{I} \\ f_b &= \frac{(49\,255.19)(12)(12/2)}{\frac{8(12^3)}{12}} \\ f_b &= 3,078.36 \text{ psi} > 1600 \text{ psi}\end{aligned}$$

Therefore, the 3.64 ft spacing of timbers is **not safe** when water reaches its maximum depth of 15 ft.

Problem 541

The 18-ft long floor beams in a building are simply supported at their ends and carry a floor load of 0.6 lb/in^2 . If the beams have $W10 \times 30$ sections, determine the center-line spacing using an allowable flexural stress of 18 ksi.

Solution 541

$$w_o = (0.6 \text{ lb/in}^2)(12 \text{ in/ft})^2(s \text{ ft})$$

$$w_o = 86.4s \text{ lb/ft}$$

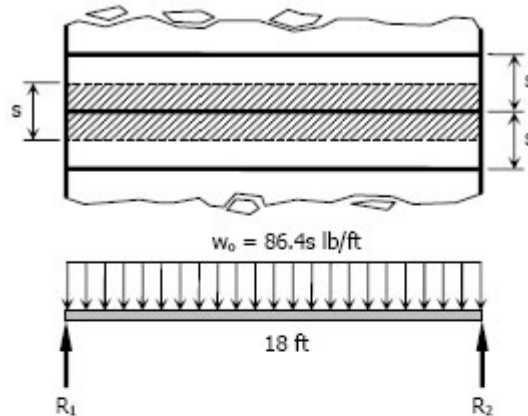

$$R_1 = R_2 = \frac{1}{2} (86.4s)(18)$$

$$= 777.6s \text{ lb}$$

$$M_{\max} = 777.6s (9) - 86.4s (9)(4.5)$$

$$= 3499.2s \text{ lb-ft}$$

From Table B-7 in Appendix B of textbook:
Properties of Wide-Flange Sections (W-Shapes): US Customary Units.

Designation	Section Modulus, S
W10 × 30	32.4 in ³

$$f_b = \frac{M}{S}$$

$$18,000 = \frac{3499.2s (12)}{32.4}$$

$$s = 13.9 \text{ ft}$$

Problem 542

Select the lightest W shape sections that can be used for the beams and girders in Illustrative Problem 537 of text book if the allowable flexural stress is 120 MPa. Neglect the weights of the members.

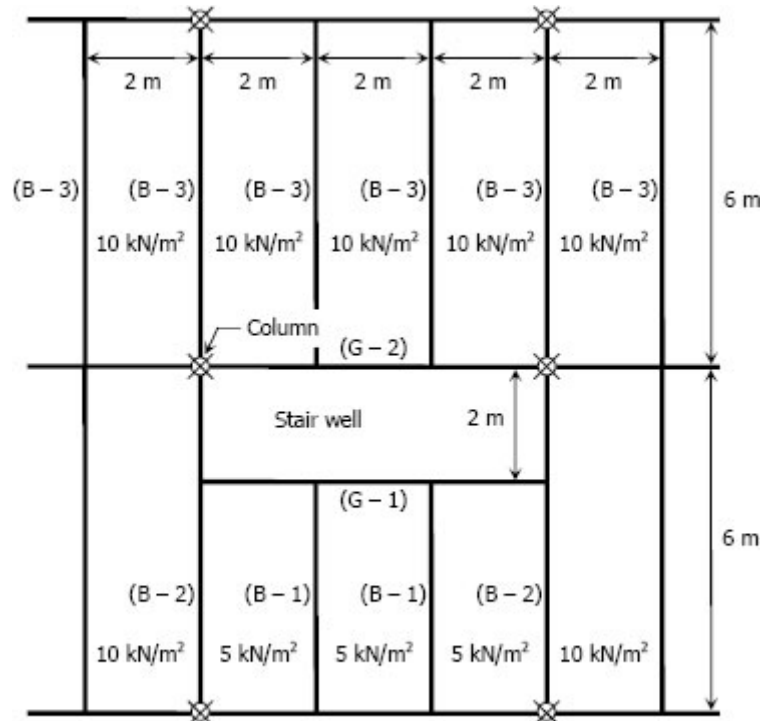

Figure in Illustrative Problem 537

Solution 542

For Beams (B - 1)

$$\begin{aligned} \text{Total Load, } W &= 5(2 \times 4) \\ &= 40 \text{ kN} \end{aligned}$$

$$\begin{aligned} \text{Distributed Load, } w_o &= W/L = 40/4 \\ &= 10 \text{ kN/m} \end{aligned}$$

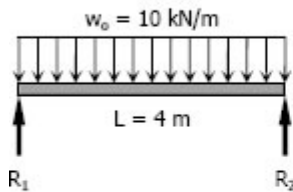

$$\begin{aligned} R_1 = R_2 &= \frac{1}{2} W = \frac{1}{2} (40) \\ &= 20 \text{ kN} \end{aligned}$$

$$\begin{aligned} M_{\max} &= R_1(L/2) - 10(L/2)(L/4) \\ &= 20(4/2) - 10(4/2)(4/4) \\ &= 20 \text{ kN}\cdot\text{m} \end{aligned}$$

$$S_{\text{required}} = \frac{M}{f_b} = \frac{20(1000^2)}{120}$$

$$S_{\text{required}} = 166\,666.67 \text{ mm}^3$$

From Appendix B, Table B-2 Properties of Wide-Flange Sections (W Shapes): SI Units, of text book:

Designation	Section Modulus
W130 × 28	$167 \times 10^3 \text{ mm}^3$
W150 × 24	$168 \times 10^3 \text{ mm}^3$
W200 × 22	$194 \times 10^3 \text{ mm}^3$
W250 × 18	$179 \times 10^3 \text{ mm}^3$

Consider W250 × 18 with $S = 179 \times 10^3 \text{ mm}^3$

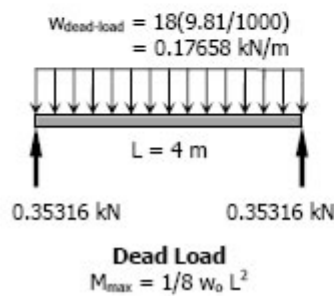

Checking:

$$S_{\text{resisting}} \geq S_{\text{live-load}} + S_{\text{dead-load}}$$

$$S_{\text{resisting}} = 179 \times 10^3 \text{ mm}^3$$

$$S_{\text{live-load}} = 166\,666.67 \text{ mm}^3$$

$$S_{\text{dead-load}} = \frac{M_{\text{dead-load}}}{f_b} = \frac{[\frac{1}{8}(0.17658)(4^2)]1000}{120}$$

$$= 2.943 \text{ mm}^3$$

$$179 \times 10^3 \geq 166\,666.67 + 2.943$$

$$179 \times 10^3 \geq 166.67 \times 10^3 \quad (\text{ok!})$$

Use W250 × 18 for B-1.

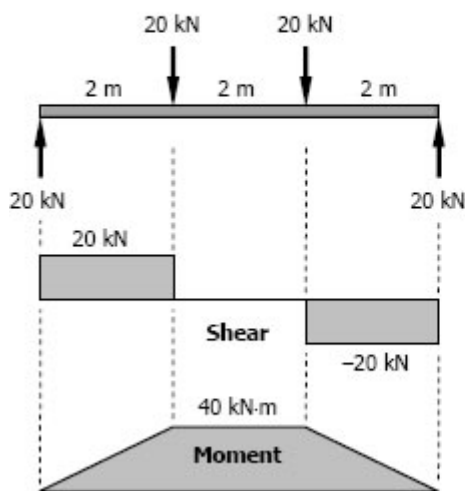

For Girder (G - 1)

$$S_{\text{live-load}} = \frac{M}{f_b} = \frac{40(1000^2)}{120}$$

$$= 333.33 \times 10^3 \text{ mm}^3$$

From Appendix B, Table B-2 Properties of Wide-Flange Sections (W Shapes): SI Units, of text book:

Designation	Section Modulus
W200 × 36	$342 \times 10^3 \text{ mm}^3$
W250 × 33	$379 \times 10^3 \text{ mm}^3$
W310 × 28	$351 \times 10^3 \text{ mm}^3$

Consider W310 × 28 with
 $S = 351 \times 10^3 \text{ mm}^3$

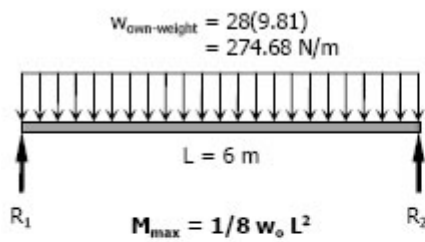

Checking:

$$S_{\text{supplied}} \geq S_{\text{required}} + S_{\text{own-weight}}$$

$$S_{\text{supplied}} = 1790 \times 10^3 \text{ mm}^3$$

$$S_{\text{required}} = 333.33 \times 10^3 \text{ mm}^3$$

$$S_{\text{own-weight}} = \frac{M_{\text{own-weight}}}{f_b}$$

$$= \frac{[\frac{1}{8}(274.68)(6^2)](1000)}{120}$$

$$= 10\,300.5 \text{ mm}^3$$

$$1790 \times 10^3 \geq (333.33 \times 10^3) + 10\,300.5$$

$$1790 \times 10^3 \geq 343.63 \times 10^3 \quad (\text{ok!})$$

Use W310 x 28 for G-1.

For Beams (B - 2)

$$\Sigma M_{R2} = 0$$

$$6R_1 = 20(4) + 10(2)(5) + 15(4)(2)$$

$$R_1 = 50 \text{ kN}$$

$$\Sigma M_{R1} = 0$$

$$6R_2 = 20(2) + 10(2)(1) + 15(4)(4)$$

$$R_2 = 50 \text{ kN}$$

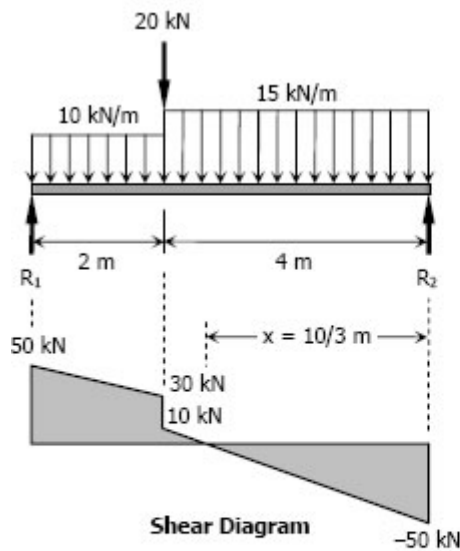

Location of Maximum Moment

$$\frac{x}{50} = \frac{4-x}{10}$$

$$10x = 200 - 50x$$

$$x = \frac{10}{3} \text{ m}$$

$$M_{\text{max}} = \frac{1}{2} \left(\frac{10}{3} \right) (50)$$

$$= \frac{250}{3} \text{ kN}\cdot\text{m}$$

$$S_{\text{required}} = \frac{M}{f_b} = \frac{\frac{250}{3}(1000^2)}{120}$$

$$= 695 \times 10^3 \text{ mm}^3$$

From Appendix B, Table B-2 Properties of Wide Flange Sections (W Shapes): SI Units, of text book:

Designation	Section Modulus
W200 × 71	$709 \times 10^3 \text{ mm}^3$
W250 × 67	$806 \times 10^3 \text{ mm}^3$
W310 × 52	$747 \times 10^3 \text{ mm}^3$
W360 × 51	$796 \times 10^3 \text{ mm}^3$
W410 × 46	$773 \times 10^3 \text{ mm}^3$

Consider W410 × 46 with $S = 773 \times 10^3 \text{ mm}^3$

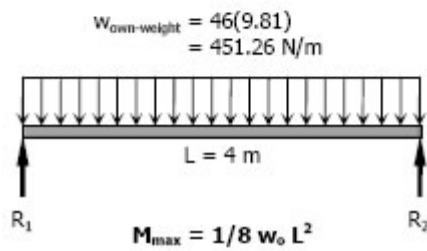

Checking:

$$S_{\text{supplied}} \geq S_{\text{required}} + S_{\text{own-weight}}$$

$$S_{\text{supplied}} = 773 \times 10^3 \text{ mm}^3$$

$$S_{\text{required}} = 695 \times 10^3 \text{ mm}^3$$

$$S_{\text{own-weight}} = \frac{M_{\text{own-weight}}}{f_b}$$

$$= \frac{\frac{1}{8}(451.26)(4^2)(1000)}{120}$$

$$= 7521 \text{ mm}^3$$

$$S_{\text{required}} + S_{\text{own-weight}} = (695 \times 10^3) + 7521$$

$$= 702\,521 \text{ mm}^3$$

$$(S_{\text{supplied}} = 773 \times 10^3 \text{ mm}^3) > 702\,521 \text{ mm}^3 \quad (\text{ok!})$$

Use W410 × 46 for B-2

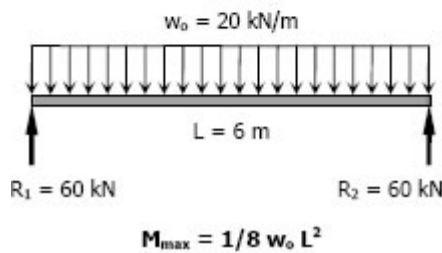

For Beams (B - 3)

$$M_{\text{max}} = \frac{1}{8} (20)(6^2)$$

$$= 90 \text{ kN}\cdot\text{m}$$

$$S_{\text{required}} = \frac{M_{\text{max}}}{f_b}$$

$$= \frac{90(1000^2)}{120}$$

$$= 750 \times 10^3 \text{ mm}^3$$

From Appendix B, Table B-2 Properties of Wide Flange Sections (W Shapes): SI Units, of text book:

Designation	Section Modulus
W200 × 86	$853 \times 10^3 \text{ mm}^3$
W250 × 67	$806 \times 10^3 \text{ mm}^3$
W310 × 60	$849 \times 10^3 \text{ mm}^3$
W360 × 51	$796 \times 10^3 \text{ mm}^3$
W410 × 46	$773 \times 10^3 \text{ mm}^3$

Consider W410 × 46 with $S = 773 \times 10^3 \text{ mm}^3$

From the Checking of B - 2

$$S_{\text{own-weight}} = 7521 \text{ mm}^3$$

$$S_{\text{required}} + S_{\text{own-weight}} = (750 \times 10^3) + 7521 \\ = 757\,521 \text{ mm}^3$$

$$(S_{\text{supplied}} = 773 \times 10^3 \text{ mm}^3) > 757\,521 \text{ mm}^3 \quad (\text{ok!})$$

Use W410 × 46 for B-3

This section is the same to B- 2

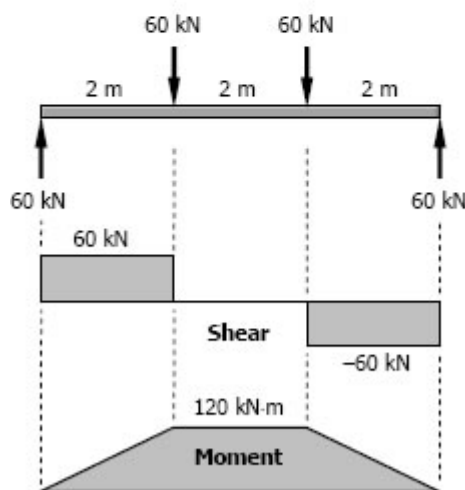

For Girders G - 2

$$S_{\text{required}} = \frac{M}{f_b} = \frac{120(1000^2)}{120} \\ = 1000 \times 10^3 \text{ mm}^3$$

From Appendix B, Table B-2 Properties of Wide-Flange Sections (W Shapes): SI Units, of text book:

Designation	Section Modulus
W250 × 89	$1100 \times 10^3 \text{ mm}^3$
W310 × 74	$1060 \times 10^3 \text{ mm}^3$
W360 × 64	$1030 \times 10^3 \text{ mm}^3$
W410 × 60	$1060 \times 10^3 \text{ mm}^3$
W460 × 60	$1120 \times 10^3 \text{ mm}^3$

There are two options, both exceeds the required S of $1000 \times 10^3 \text{ mm}^3$. One is W410 × 60 with theoretical mass of 59.5 kg/m and the other is W460 × 60 with

theoretical mass of 59.6 kg/m. For economic reason, we prefer W410 × 60.

Checking:

$$S_{\text{supplied}} \geq S_{\text{required}} + S_{\text{own-weight}}$$

$$S_{\text{supplied}} = 1060 \times 10^3 \text{ mm}^3$$

$$S_{\text{required}} = 1000 \times 10^3 \text{ mm}^3$$

$$S_{\text{own-weight}} = \frac{M_{\text{own-weight}}}{f_b}$$

$$= \frac{\frac{1}{8}(588.6)(6^2)(1000)}{120}$$

$$= 22\,072.5 \text{ mm}^3$$

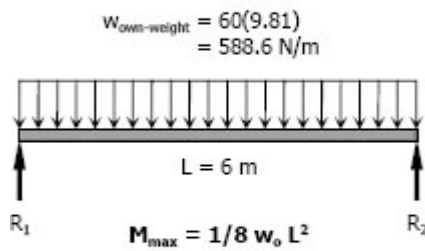

$$S_{\text{required}} + S_{\text{own-weight}} = (1000 \times 10^3) + 22\,072.5$$

$$= 1\,022\,072.5 \text{ mm}^3$$

$$(S_{\text{supplied}} = 1060 \times 10^3 \text{ mm}^3) > 1\,022\,072.5 \text{ mm}^3 \text{ (ok!)}$$

Use W410 × 60 for G-2

Summary:

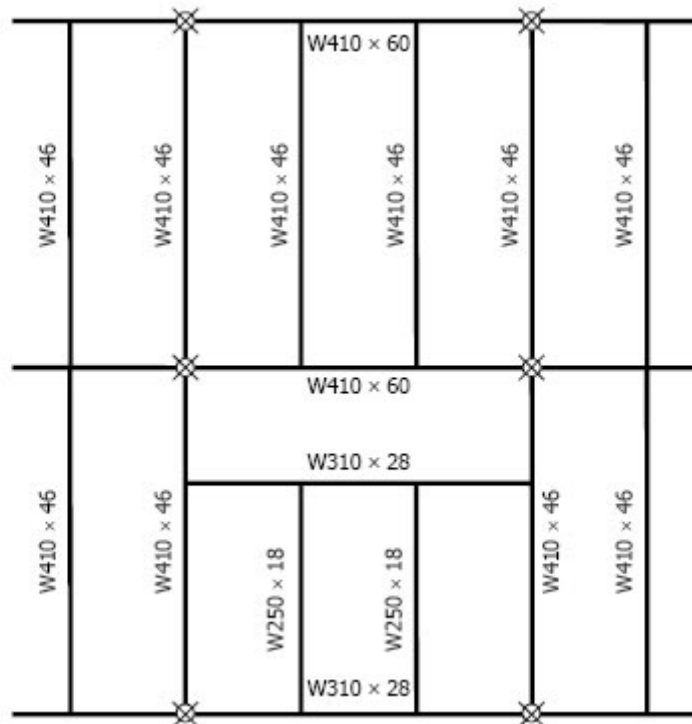

Problem 543

A portion of the floor plan of a building is shown in Fig. P-543. The total loading (including live and dead loads) in each bay is as shown. Select the lightest suitable W if the allowable flexural stress is 120 MPa.

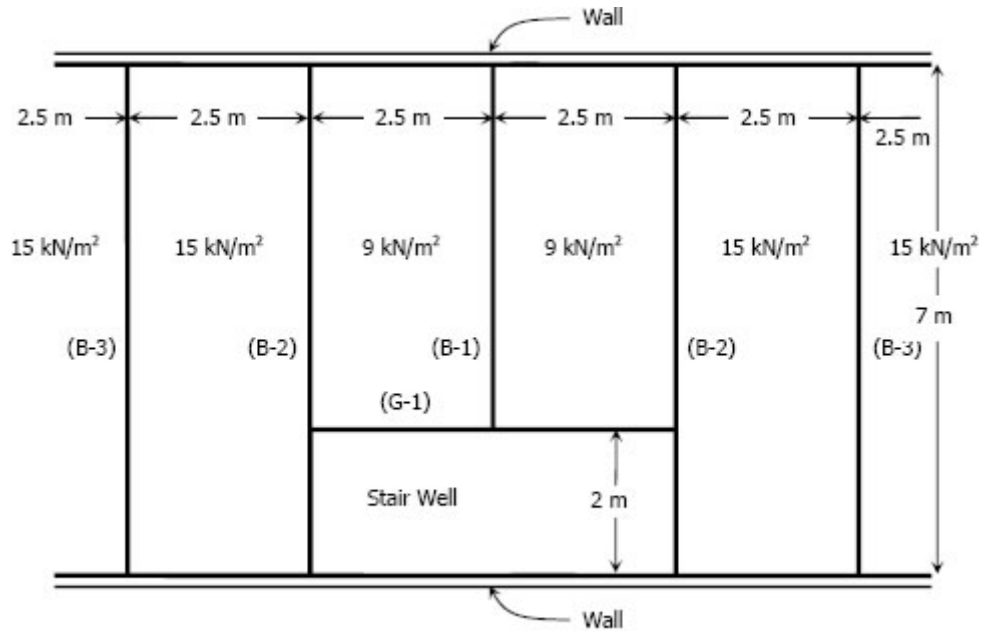
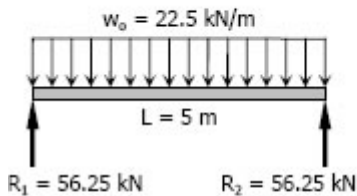

Figure P-543

Solution 543



Member B - 1
 $M_{max} = 1/8 w_o L^2$

For Member B - 1

$$S_{required} = \frac{M}{f_b}$$

$$= \frac{1/8 (22.5)(5^2)(1000^2)}{120}$$

$$= 586 \times 10^3 \text{ mm}^3$$

From Appendix B, Table B-2 Properties of Wide-Flange Sections (W Shapes): SI Units, of text book:

Use W410 x 39 with $S = 634 \times 10^3 \text{ mm}^3$ for member B - 1.

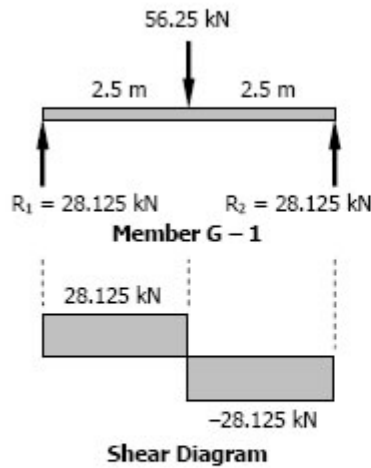

For Member G - 1

$$M = 2.5(28.125)$$

$$= 70.3125 \text{ kN}\cdot\text{m}$$

$$S_{\text{required}} = \frac{M}{f_b}$$

$$= \frac{70.3125(1000^2)}{120}$$

$$= 586 \times 10^3 \text{ mm}^3$$

From Appendix B, Table B-2 Properties of Wide-Flange Sections (W Shapes): SI Units, of text book:

Use W410 x 39 with $S = 634 \times 10^3 \text{ mm}^3$ for member G - 1.

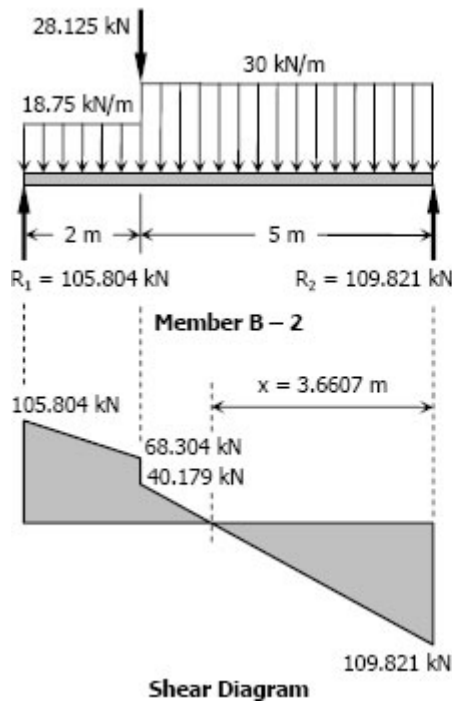

For Member B - 2:

$$\Sigma M_{R2} = 0$$

$$7R_1 = 28.125(5) + 18.75(2)(6)$$

$$+ 30(5)(2.5)$$

$$R_1 = 105.804 \text{ kN}$$

$$\Sigma M_{R1} = 0$$

$$7R_2 = 28.125(2) + 18.75(2)(1)$$

$$+ 30(5)(4.5)$$

$$R_2 = 109.821 \text{ kN}$$

Location of Maximum Moment:

$$\frac{x}{109.821} = \frac{5-x}{40.179}$$

$$40.179x = 549.105 - 109.821x$$

$$x = 3.6607 \text{ m}$$

Maximum Moment

$$M = \frac{1}{2} (3.6607)(109.821)$$

$$= 201.01 \text{ kN}\cdot\text{m}$$

$$S_{\text{required}} = \frac{M}{f_b} = \frac{201.01(1000^2)}{120}$$

$$S_{\text{required}} = 1\,675 \times 10^3 \text{ mm}^3$$

From Appendix B, Table B-2 Properties of Wide-Flange Sections (W Shapes): SI Units, of text book:

Use W610 × 82 with $S = 1\,870 \times 10^3 \text{ mm}^3$ for member B - 2.

For Member B - 3

$$S_{\text{required}} = \frac{M}{f_b} = \frac{\frac{1}{8}(37.5)(7^2)(1000^2)}{120}$$

$$S_{\text{required}} = 1\,914 \times 10^3 \text{ mm}^3$$

From Appendix B, Table B-2 Properties of Wide-Flange Sections (W Shapes): SI Units, of text book:

Use W610 × 92 with $S = 2\,140 \times 10^3 \text{ mm}^3$ for member B - 3.

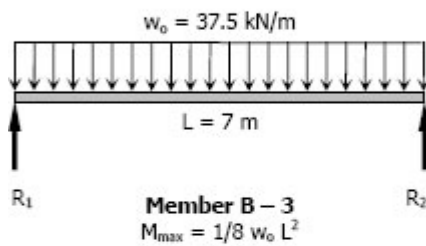

Summary:

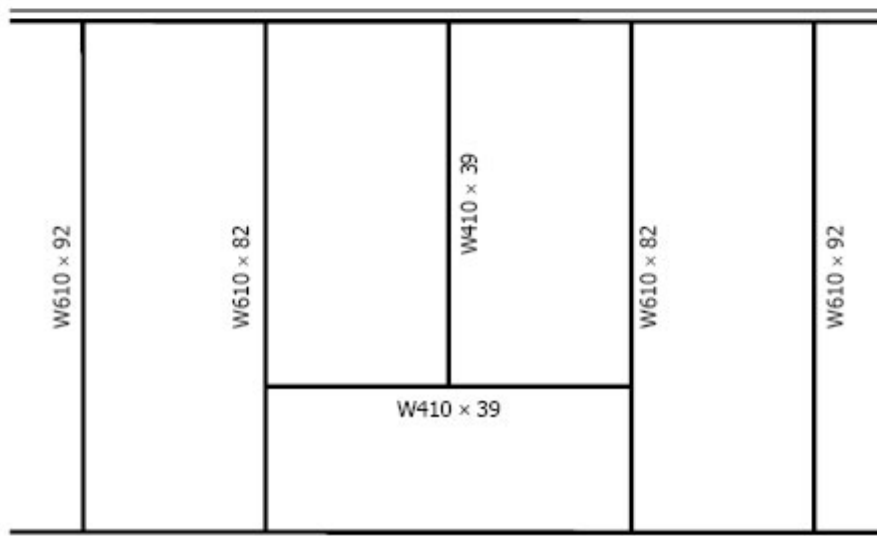

Unsymmetrical Beams

Flexural Stress varies directly linearly with distance from the neutral axis. Thus for a symmetrical section such as wide flange, the compressive and tensile stresses will be the same. This will be desirable if the material is both equally strong in tension and compression. However, there are materials, such as cast iron, which are strong in compression than in tension. It is therefore desirable to use a beam with unsymmetrical cross section giving more area in the compression part making the stronger fiber located at a greater distance from the neutral axis than the weaker fiber. Some of these sections are shown below.

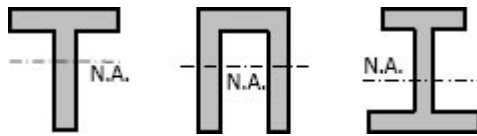

The proportioning of these sections is such that the ratio of the distance of the neutral axis from the outermost fibers in tension and in compression is the same as the ratio of the allowable stresses in tension and in compression. Thus, the allowable stresses are reached simultaneously.

In this section, the following notation will be use:

f_{bt} = flexure stress of fiber in tension

f_{bc} = flexure stress of fiber in compression

N.A. = neutral axis

y_t = distance of fiber in tension from N.A.

y_c = distance of fiber in compression from N.A.

M_r = resisting moment

M_c = resisting moment in compression

M_t = resisting moment in tension

Solved Problems in Unsymmetrical Beams

Problem 548

The inverted T section of a 4-m simply supported beam has the properties shown in Fig. P-548. The beam carries a uniformly distributed load of intensity w_0 over its entire length. Determine w_0 if $f_{bt} \leq 40$ MPa and $f_{bc} \leq 80$ MPa.

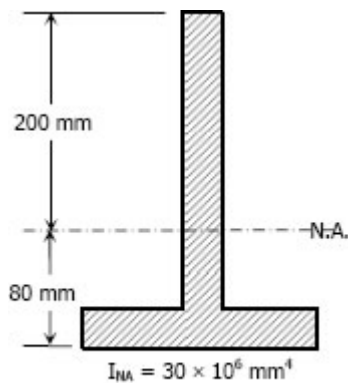
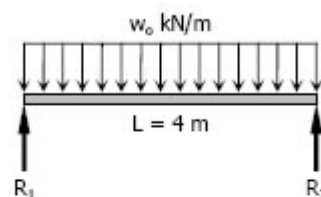

Figure P-548

Solution 548

$$\begin{aligned} M_{\max} &= \frac{1}{8} w_0 L^2 \\ &= \frac{1}{8} w_0 (4^2) \\ &= 2w_0 \end{aligned}$$

$$M_r = \frac{f_b I}{y}$$



Member B – 1
 $M_{\max} = 1/8 w_0 L^2$

$$\begin{aligned} M_t &= \frac{40(30 \times 10^6)}{80} \\ &= 15\,000\,000 \text{ N}\cdot\text{mm} \\ &= 15 \text{ kN}\cdot\text{mm} \end{aligned}$$

$$\begin{aligned} M_c &= \frac{80(30 \times 10^6)}{200} \\ &= 12\,000\,000 \text{ N}\cdot\text{mm} \\ &= 12 \text{ kN}\cdot\text{mm} \end{aligned}$$

The section is stronger in tension and weaker in compression, so compression governs in selecting the maximum moment.

$$\begin{aligned} M_{\max} &= M_r \\ 2w_0 &= 12 \\ w_0 &= 6 \text{ kN/m} \end{aligned}$$

Problem 549

A beam with cross-section shown in Fig. P-549 is loaded in such a way that the maximum moments are $+1.0P$ lb·ft and $-1.5P$ lb·ft, where P is the applied load in pounds. Determine the maximum safe value of P if the working stresses are 4 ksi in tension and 10 ksi in compression.

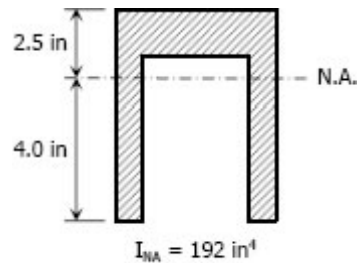

Figure P-549

Solution 549

At $M = +1.0P$ lb·ft the upper fiber is in compression while the lower fiber is in tension.

$$M = M_c$$
$$M = \frac{f_b I}{y}$$

For fibers in compression (upper fiber):

$$M_c = \frac{10(192)(1000)}{2.5}$$

$$1.0P = 768\,000 \text{ lb·in}$$

$$1.0P = 64\,000 \text{ lb·ft}$$

$$P = 64\,000 \text{ lb}$$

For fibers in tension (lower fiber):

$$M_c = \frac{4(192)(1000)}{4}$$

$$1.0P = 192\,000 \text{ lb·in}$$

$$1.0P = 16\,000 \text{ lb·ft}$$

$$P = 16\,000 \text{ lb}$$

At $M = -1.5P$ lb·ft, the upper fiber is in tension while the lower fiber is in compression.

$$M = M_c$$
$$M = \frac{f_b I}{y}$$

For fibers in compression (lower fiber):

$$M_c = \frac{10(192)(1000)}{4}$$

$$1.5P = 480\,000 \text{ lb-in}$$

$$1.5P = 40\,000 \text{ lb-ft}$$

$$P = 26\,666.67 \text{ lb}$$

For fibers in tension (upper fiber):

$$M_c = \frac{4(192)(1000)}{2.5}$$

$$1.5P = 307\,200 \text{ lb-in}$$

$$1.5P = 25\,600 \text{ lb-ft}$$

$$P = 17\,066.67 \text{ lb}$$

The safe load $P = 16\,000 \text{ lb}$

Problem 550

Resolve Prob. 549 if the maximum moments are $+2.5P \text{ lb-ft}$ and $-5.0P \text{ lb-ft}$.

Solution 550

At $M = +2.5P$

$$M_c = \frac{10(192)(1000)}{2.5} \quad \rightarrow \text{upper fiber}$$

$$2.5P = 768\,000 \text{ lb-in}$$

$$2.5P = 64\,000 \text{ lb-ft}$$

$$P = 25\,600 \text{ lb}$$

$$M_t = \frac{4(192)(1000)}{4} \quad \rightarrow \text{lower fiber}$$

$$2.5P = 192\,000 \text{ lb-in}$$

$$2.5P = 16\,000 \text{ lb-ft}$$

$$P = 6400 \text{ lb}$$

At $M = -5.0P \text{ lb-ft}$

$$M_c = \frac{10(192)(1000)}{4} \quad \rightarrow \text{lower fiber}$$

$$5.0P = 480\,000 \text{ lb-in}$$

$$5.0P = 40\,000 \text{ lb-ft}$$

$$P = 8000 \text{ lb}$$

$$M_t = \frac{4(192)(1000)}{2.5} \quad \rightarrow \text{upper fiber}$$

$$5.0P = 307\,200 \text{ lb-in}$$

$$5.0P = 25\,600 \text{ lb-ft}$$

$$P = 5120 \text{ lb}$$

Use $P = 5120 \text{ lb}$

Problem 551

Find the maximum tensile and compressive flexure stresses for the cantilever beam shown in Fig. P-551.

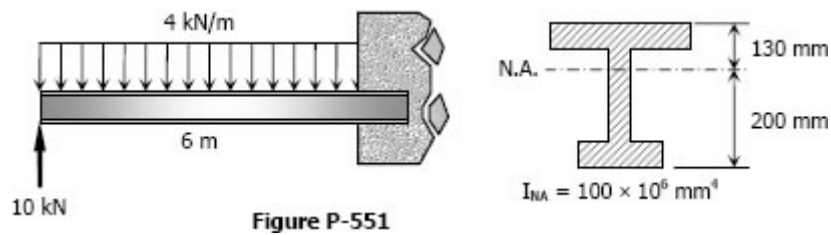

Solution 551

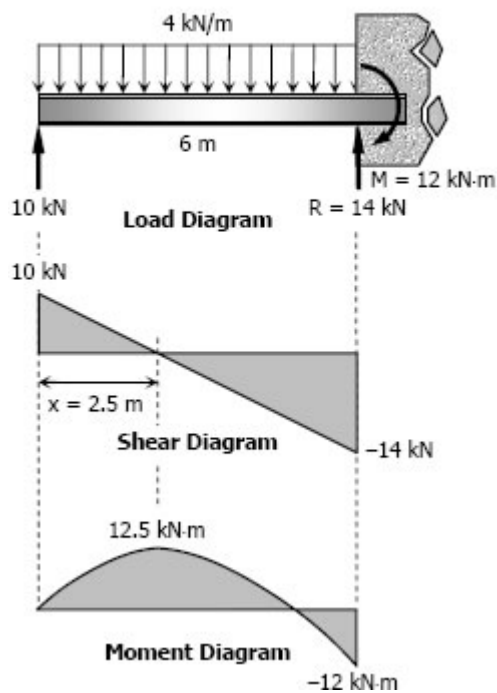

$$M = 4(6)(3) - 10(6) \\ = 12 \text{ kN}\cdot\text{m}$$

$$R = 4(6) - 10 \\ = 14 \text{ kN}$$

$$\frac{x}{10} = \frac{6-x}{14} \\ 14x = 60 - 10x \\ x = 2.5 \text{ m}$$

$$f_b = \frac{My}{I}$$

At $M = +12.5 \text{ kN}\cdot\text{m}$

$$f_{bc} = \frac{12.5(130)(1000^2)}{100 \times 10^6} \\ = 16.25 \text{ MPa} \rightarrow \text{upper fiber}$$

$$f_{bt} = \frac{12.5(200)(1000^2)}{100 \times 10^6} \\ = 25 \text{ MPa} \rightarrow \text{lower fiber}$$

At $M = -12 \text{ kN}\cdot\text{m}$

$$f_{bc} = \frac{12(200)(1000^2)}{100 \times 10^6} \\ = 24 \text{ MPa} \rightarrow \text{lower fiber}$$

$$f_{bt} = \frac{12(130)(1000^2)}{100 \times 10^6} \\ = 15.6 \text{ MPa} \rightarrow \text{upper fiber}$$

Maximum flexure stresses:

$$f_{bc} = 24 \text{ MPa at the fixed end} \\ f_{bt} = 25 \text{ MPa at 2.5 m from the free end}$$

Problem 552

A cantilever beam carries the force and couple shown in Fig. P-552. Determine the maximum tensile and compressive bending stresses developed in the beam.

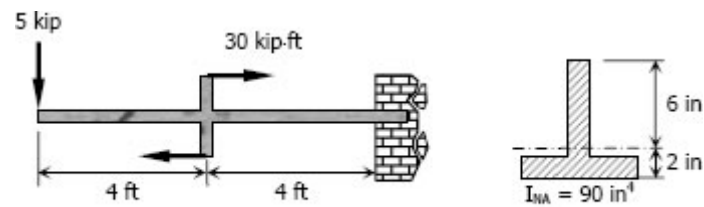
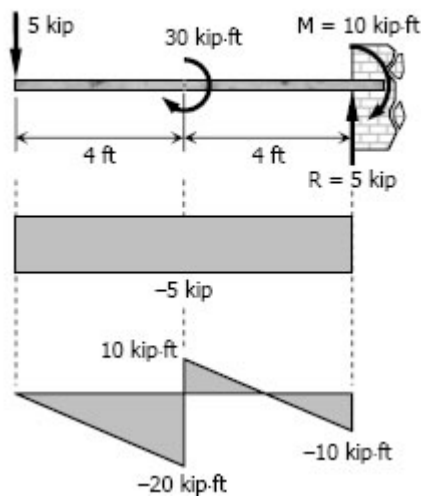

Figure P-552

Solution 552



$$R = 5 \text{ kip}$$

$$M = 5(8) - 30$$

$$= 10 \text{ kip-ft}$$

$$f_b = \frac{My}{I}$$

At $M = +10 \text{ kip-ft}$ of moment diagram

$$f_{bc} = \frac{10(6)(12)}{90}$$

$$= 8 \text{ ksi} \quad \rightarrow \text{upper fiber}$$

$$f_{bt} = \frac{10(2)(12)}{90}$$

$$= 2.67 \text{ ksi} \quad \rightarrow \text{lower fiber}$$

At $M = -20 \text{ kip-ft}$ of moment diagram

$$f_{bc} = \frac{20(2)(12)}{90}$$

$$= 5.33 \text{ ksi} \quad \rightarrow \text{lower fiber}$$

$$f_{bt} = \frac{20(6)(12)}{90}$$

$$= 16 \text{ ksi} \quad \rightarrow \text{upper fiber}$$

Maximum bending stresses:

$$f_{bc} = 8 \text{ ksi}$$

$$f_{bt} = 16 \text{ ksi}$$

Problem 553

Determine the maximum tensile and compressive bending stresses developed in the beam as shown in Fig. P-553.

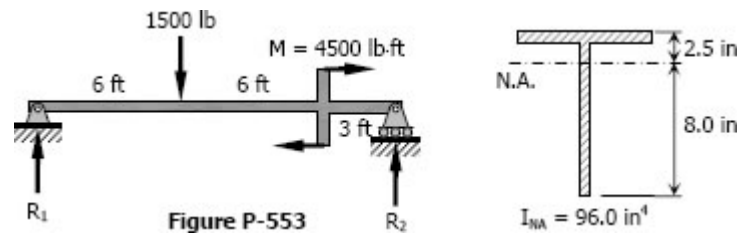

Solution 553

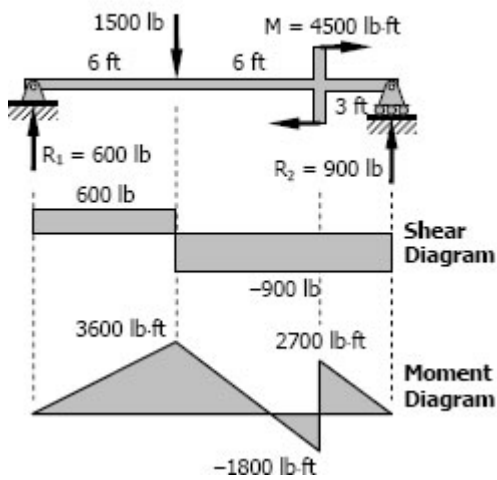

$$\begin{aligned} \Sigma M_{R2} &= 0 \\ 15R_1 + 4500 &= 1500(9) \\ R_1 &= 600 \text{ lb} \end{aligned}$$

$$\begin{aligned} \Sigma M_{R1} &= 0 \\ 15R_2 &= 1500(6) + 4500 \\ R_2 &= 900 \text{ lb} \end{aligned}$$

$$f_b = \frac{My}{I}$$

At $M = +3600 \text{ lb-ft}$

$$\begin{aligned} f_{bc} &= \frac{3600(2.5)(12)}{96.0} \\ &= 1125 \text{ psi} \rightarrow \text{upper fiber} \end{aligned}$$

$$\begin{aligned} f_{bt} &= \frac{3600(8.0)(12)}{96.0} \\ &= 3600 \text{ psi} \rightarrow \text{lower fiber} \end{aligned}$$

At $M = -1800 \text{ lb-ft}$

$$\begin{aligned} f_{bc} &= \frac{1800(8.0)(12)}{96.0} \\ &= 1800 \text{ psi} \rightarrow \text{lower fiber} \end{aligned}$$

$$\begin{aligned} f_{bt} &= \frac{1800(2.5)(12)}{96.0} \\ &= 562.5 \text{ psi} \rightarrow \text{upper fiber} \end{aligned}$$

Maximum flexure stresses

$$f_{bc} = 1800 \text{ psi}$$

$$f_{bt} = 3600 \text{ psi}$$

Problem 554

Determine the maximum tensile and compressive stresses developed in the overhanging beam shown in Fig. P-554. The cross-section is an inverted T with the given properties.

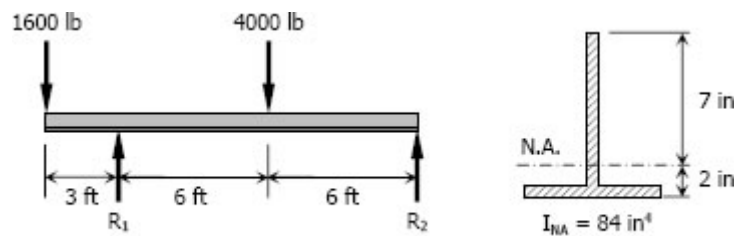
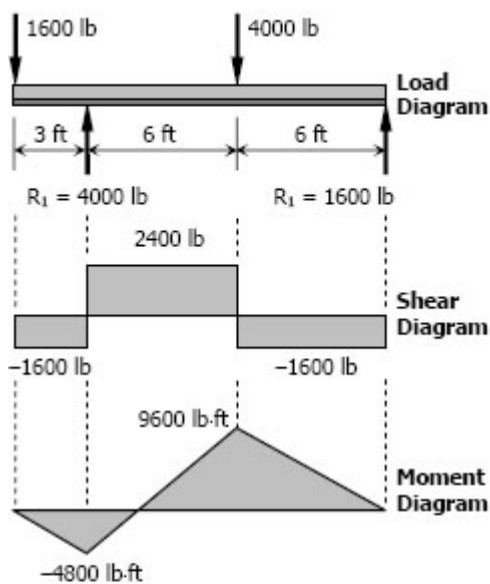

Figure P-554

Solution 554

$$\begin{aligned}\Sigma M_{R2} &= 0 \\ 12R_1 &= 1600(15) + 4000(6) \\ R_1 &= 4000 \text{ lb}\end{aligned}$$

$$\begin{aligned}\Sigma M_{R1} &= 0 \\ 12R_2 + 1600(3) &= 4000(6) \\ R_2 &= 1600 \text{ lb}\end{aligned}$$



$$f_b = \frac{My}{I}$$

At $M = -4800 \text{ lb-ft}$

$$\begin{aligned}f_{bc} &= \frac{4800(2)(12)}{84} \\ &= 1371.43 \text{ psi} \rightarrow \text{lower fiber}\end{aligned}$$

$$\begin{aligned}f_{bt} &= \frac{4800(7)(12)}{84} \\ &= 4800 \text{ psi} \rightarrow \text{upper fiber}\end{aligned}$$

At $M = +9600 \text{ lb-ft}$

$$\begin{aligned}f_{bc} &= \frac{9600(7)(12)}{84} \\ &= 9600 \text{ psi} \rightarrow \text{upper fiber}\end{aligned}$$

$$\begin{aligned}f_{bt} &= \frac{9600(2)(12)}{84} \\ &= 2742.86 \text{ psi} \rightarrow \text{lower fiber}\end{aligned}$$

Maximum flexure stress:

$$\begin{aligned}f_{bc} &= 9600 \text{ psi} \\ f_{bt} &= 4800 \text{ psi}\end{aligned}$$

Problem 555

A beam carries a concentrated load W and a total uniformly distributed load of $4W$ as shown in Fig. P-555. What safe value of W can be applied if $f_{bc} \leq 100$ MPa and $f_{bt} \leq 60$ MPa? Can a greater load be applied if the section is inverted? Explain.

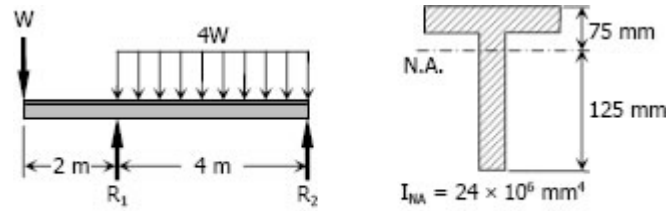
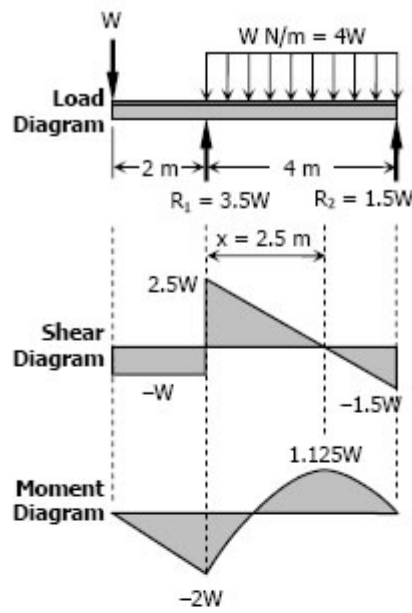

Figure P-555

Solution 555



$$[\Sigma M_{R2} = 0] \quad 4R_1 = 6W + 4W(2)$$

$$R_1 = 3.5W$$

$$[\Sigma M_{R1} = 0] \quad 4R_2 + 2W = 4W(2)$$

$$R_2 = 1.5W$$

$$\frac{x}{2.5W} = \frac{4-x}{1.5W}$$

$$1.5Wx = 10W - 2.5Wx$$

$$x = 2.5 \text{ m}$$

$$f_b = \frac{My}{I}$$

At $M = -2W$

For lower fiber, $f_{bc} \leq 100 \text{ MPa}$

$$100 = \frac{2W(125)(1000)}{24 \times 10^6}$$

$$W = 9600 \text{ N}$$

For upper fiber, $f_{bt} \leq 60 \text{ MPa}$

$$60 = \frac{2W(75)(1000)}{24 \times 10^6}$$

$$W = 9600 \text{ N}$$

At $M = 1.125W$

For upper fiber, $f_{bc} \leq 100 \text{ MPa}$

$$100 = \frac{1.125W(75)(1000)}{24 \times 10^6}$$

$$W = 28,444.44 \text{ N}$$

For lower fiber, $f_{bt} \leq 60 \text{ MPa}$

$$60 = \frac{1.125W(125)(1000)}{24 \times 10^6}$$

$$W = 10,240 \text{ N}$$

For safe load W , use $W = 9600 \text{ N}$

Discussion:

At $W = 9600 \text{ N}$, the allowable f_b in tension and compression are reached simultaneously when $M = -2W$. This is the same even if the section is inverted. Therefore, no load can be applied greater than $W = 9600 \text{ N}$.

Problem 556

A T beam supports the three concentrated loads shown in Fig. P-556. Prove that the NA is 3.5 in. above the bottom and that $I_{NA} = 97.0 \text{ in}^4$. Then use these values to determine the maximum value of P so that $f_{bt} \leq 4 \text{ ksi}$ and $f_{bc} \leq 10 \text{ ksi}$.

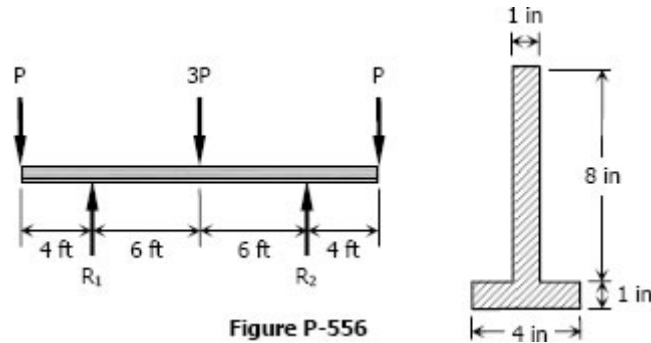
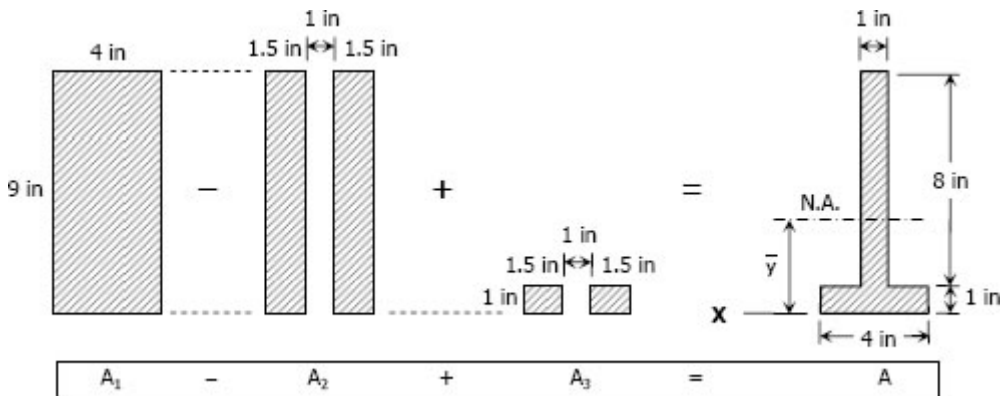

Figure P-556

Solution 556



$$\begin{aligned}
 A_1 &= 9(4) = 36 \text{ in}^2 \\
 A_2 &= 9(1.5)(2) = 27 \text{ in}^2 \\
 A_3 &= 1(1.5)(2) = 3 \text{ in}^2 \\
 A &= A_1 - A_2 + A_3 \\
 &= 36 - 27 + 3 \\
 &= 12 \text{ in}^2
 \end{aligned}$$

$$\begin{aligned}
 A\bar{y} &= \Sigma A_n \bar{y} \\
 12\bar{y} &= 36(4.5) - 27(4.5) + 3(0.5) \\
 \bar{y} &= 3.5 \text{ in} \quad (\text{ok!})
 \end{aligned}$$

$$I_x = \sum \left(\frac{bh^3}{3} \right)_n$$

$$I_x = \frac{4(9^3)}{3} - 2 \cdot \frac{1.5(9^3)}{3} + 2 \cdot \frac{1.5(1^3)}{3}$$

$$I_x = 244 \text{ in}^4$$

By transfer formula for moment of inertia:

$$I_x = I_{NA} + Ad^2$$

$$244 = I_{NA} + 12(3.5)^2$$

$$I_{NA} = 97 \text{ in}^4 \quad (\text{ok!})$$

By symmetry:

$$R_1 = R_2 = 2.5P$$

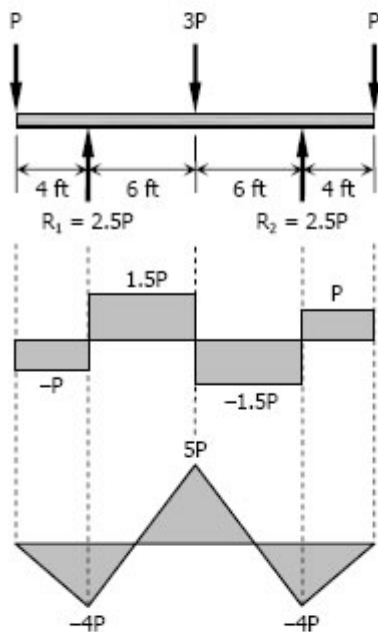

$$f_b = \frac{My}{I}$$

At $M = -4P \text{ lb}\cdot\text{ft}$

Lower fiber is in compression:

$$10,000 = \frac{4P(3.5)(12)}{97}$$

$$P = 5773.81 \text{ lb}$$

Upper fiber is in tension:

$$4000 = \frac{4P(9 - 3.5)(12)}{97}$$

$$P = 1469.7 \text{ lb}$$

At $M = 5P \text{ lb}\cdot\text{ft}$

Lower fiber is in tension:

$$4000 = \frac{4P(3.5)(12)}{97}$$

$$P = 2309.52 \text{ lb}$$

Upper fiber is in compression

$$10,000 = \frac{4P(9 - 3.5)(12)}{97}$$

$$P = 3674.24 \text{ lb}$$

For safe value of P , use $P = 1469.7 \text{ lb}$

Problem 557

A cast-iron beam 10 m long and supported as shown in Fig. P-557 carries a uniformly distributed load of intensity w_0 (including its own weight). The allowable stresses are $f_{bt} \leq 20$ MPa and $f_{bc} \leq 80$ MPa. Determine the maximum safe value of w_0 if $x = 1.0$ m.

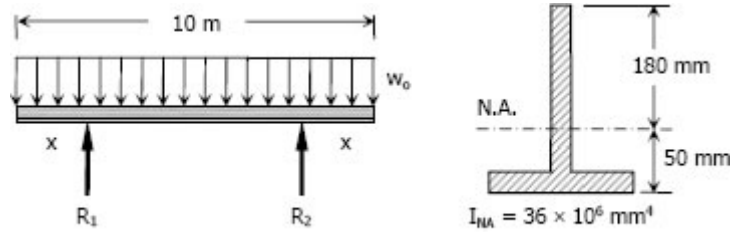
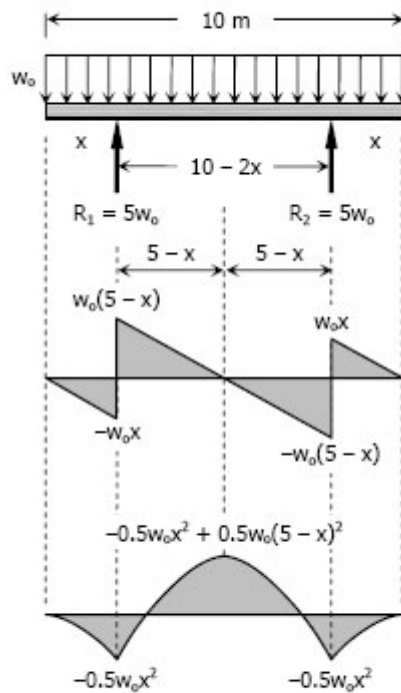

Figure P-557 and P-558

Solution 557

By symmetry:

$$R_1 = R_2 = \frac{1}{2}(10w_0) = 5w_0$$



$$f_b = \frac{My}{I}$$

At $M = -0.5w_0x^2$ N·m

when $x = 1$ m, $M = -0.5w_0$ N·m

For fiber in compression (lower)

$$80 = \frac{0.5w_0(50)(1000)}{36 \times 10^6}$$

$$w_0 = 115\,200 \text{ N/m}$$

$$w_0 = 115.2 \text{ kN/m}$$

For fiber in tension (upper)

$$20 = \frac{0.5w_0(180)(1000)}{36 \times 10^6}$$

$$w_0 = 8000 \text{ N/m}$$

$$w_0 = 8 \text{ kN/m}$$

At $M = -0.5w_0x^2 + 0.5w_0(5-x)^2$ N·m

when $x = 1$ m, $M = 7.5w_0$ N·m

For fiber in compression (upper)

$$80 = \frac{7.5w_0(180)(1000)}{36 \times 10^6}$$

$$w_0 = 2133.33 \text{ N/m}$$

$$w_0 = 2.13 \text{ kN/m}$$

For fiber in tension (lower)

$$20 = \frac{7.5w_0(50)(1000)}{36 \times 10^6}$$

$$w_0 = 1920 \text{ N/m}$$

$$w_0 = 1.92 \text{ kN/m}$$

For safe load w_0 , use $w_0 = 1.92$ kN/m

Problem 558

In Prob. 557, find the values of x and w_0 so that w_0 is a maximum.

Solution 558

From Solution 557, tension governs at both positive and negative maximum moments.

At $M = -0.5w_0x^2$ N·m:

$$20 = \frac{0.5w_0x^2(180)(1000)}{36 \times 10^6}$$

$$w_0 = 8000/x^2$$

At $M = -0.5w_0x^2 + 0.5w_0(5-x)^2$ N·m:

$$20 = \frac{[-0.5w_0x^2 + 0.5w_0(5-x)^2](50)(1000)}{36 \times 10^6}$$

$$14\,400 = -0.5w_0x^2 + 0.5w_0(5-x)^2$$

$$28\,800 = -w_0x^2 + w_0(5-x)^2$$

$$28\,800 = -w_0x^2 + w_0(25 - 10x + x^2)$$

$$28\,800 = -w_0x^2 + (25 - 10x)w_0 + w_0x^2$$

$$28\,800 = (25 - 10x)w_0$$

$$28\,800 = (25 - 10x)(8\,000/x^2)$$

$$(28\,800x^2 / 8000) = 25 - 10x$$

$$\frac{18}{5}x^2 = 25 - 10x$$

$$18x^2 = 125 - 50x$$

$$18x^2 + 50x - 125 = 0$$

$$x = 1.59 \text{ m and } -4.37 \text{ (meaningless)}$$

use $x = 1.59 \text{ m}$

$$w_0 = 8000 / 1.59^2$$

$$w_0 = 3164.43 \text{ N/m}$$

$$w_0 = 3.16 \text{ kN/m}$$